



LIQUIP AVIATION COMPONENTS PRODUCT OVERVIEW

LIQUIP 
PART OF OPW a **DOVER** company



Aviation Components Catalogue

Hosereels & Fittings

Elaflex Aviation Hose
Elaflex Hose Fittings
Hose Swivels
Hose Quick Disconnect
Hose Beads
Hose Reflective Cover
Aviation Hosereel Drum Style - HP Series
Aviation Hosereel Drum Style - AHR Series
Aviation Hosereel Cartwheel Style - AHR Series
Hosereel Assemblies - Electric Rewind

Nozzles & Accessories

OPW295SA & SAJ Aircraft Nozzles
AV042 Overwing Nozzle
Elaflex Nozzle Bowser
Nozzle Overwing
Nozzle Stowage

Bottom Load Accessories

OPW EuroLine Series Foot Valve
Normec Internal Footvalve

Hydrants

Hydrant Pit
Hydrant Pit - HPA100
Hydrant Pit - HPA150
Hydrant Pit - HPA200
Hydrant Pit - HPA250
EN Approved Hydrant Pits
Tether

Valves

Non-Return Valves - NRV80
Stainless Steel Flanged Ball Valves
Small Isolation Ball Valves
Apollo Valve
Tank Compartment Internal Drain Valve
ATS Tank Sump

Fuel Sampling

Epoxy Lined Container
Collector Tank
Millipore Adaptor
Aljac Sampler

Gauges

Schultz Differential Pressure Gauges
Pressure Gauges

Meters & Pumps

Electronic Meter Register - DFV Series
Pulser - ERP200
Junction Box - EJB101
Sampi Meters
Sampi Meters - SM 5
Sampi Meters - SM 30
Isoil Digital Display - LFD-6
Gorman Rupp Pump 2"
Gorman Rupp Pump 3"
Portable Aviation Drum Pump
Avery Hardoll BM Series Meter

Overfill Protection

Liquip Detection Probes - LDP Series
Probe Holders
On Board Monitor

Accessories

Filter Standard Sensing Assemblies
Facet Small Filter Housings - VF-21 and VF-22 Series
ILS400 In-line Suction Strainer
Basket Strainers
Elaflex Rubber Expansion Joints
Swivels
Camlocks
Static Reel - LSR Series
Aljac Continuity Tester
Power Conditioner
Deadman Assemblies
Decals & Signage
Spill Management Products
Platform Ladders
Wing Mats
Stainless Steel Buckets
Fire Extinguisher Holder
Stainless Steel Safety Lock Wire
Water Finding Paste
Fuel Finding (Ullage) Paste
Density Calculator



Hosereels & Fittings

Elaflex Aviation Hose

Yellow band aircraft refuelling hoses, suitable for all aviation gasoline and jet fuels (JET A1), anti-icing fluids and motor oils.

Elaflex standard type "HD-C" with two textile braids. Light weight, flexible hose for all pressure purposes.

NOTE: Not for suction. Burst pressure > 80 bar / 1200psi.
The hose does not kink with a permanent pressure of at least 0.5 bar

- Temperature range: -30° up to +70° Celsius
- Electrical resistance: Between 103 and 106 Ohm
- Lining: Nitrile rubber (NBR) seamless tube, antistatic, no fuel solubility.
- Reinforcement: Textile braids without metallic strands.
- Cover: Chloroprene (CR), electrically conductive, ozone and flame resistant, highly abrasion resistant

Approved to EN1361 (European) , AS2683 (Australian) and API1529 (American) Standards.

Specified by almost all major oil companies.



Type HD-C
EN 1361 - type C



Ordering Information

Part No:	Size ID		OD mm	Working Pressure bar	Max. Vacuum bar	Min reel diameter mm	Approx. Weight kg / m
	inches	mm					
3343	1	25	37	20	0.5	200	0.8
3344	1 1/4	32	44		0.4	225	1.0
3345	1 1/2	38	51		0.3	270	1.2
3346	2	50	66		0.2	400	1.9
3347	2 1/2	63	79		0.15	600	2.4
3348	3	75	91		-	600	2.8
3349	4	100	117		-	900	3.7
					-	900	3.7

Elaflex Hose Fittings

Male & female threaded couplings in brass nickel plated with Quick Clamp Type in either pin or bolt style to international standards. Working pressure up to 25 bar.

Supplied separately or part of complete tested hose assembly.

These hose clamps and hose tails are used on most if not all LIQUIP aviation fuelling vehicles and other special fuel handling equipment or vehicles.

Ordering Information

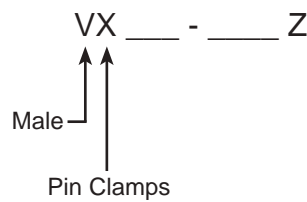
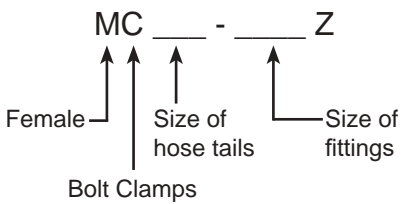

Example: MC 25 - 1 Z 1" hoesetail x 1" female BSPP with bolt clamp
 VX 25 - 1.25Z 1" hoesetail x 1 1/4" Male BSPP with pin clamp



Male Fitting



Female Fitting



Spannloc Hose Clamp
(Bolt type)



Spannfix Hose Clamp
(Pin type)

FITTINGS			
Hose Tail + Bolt Clamps (Spannloc)			
FEMALE		MALE	
MC 25	- 1 Z	VC 25	- 1 Z
	- 1.25 Z		- 1.25 Z
MC 32	- 1.25 Z	VC 32	- 1.25 Z
	- 1.5 Z		- 1.5 Z
MC 38	- 1.5 Z	VC 38	- 1.5 Z
	- 2 Z		- 2 Z
MC 50	- 2 Z	VC 50	- 2 Z
	- 2.5 Z		- 2.5 Z
MC 63	- 2.5 Z	VC 63	- 2.5 Z
	- 3 Z		- 3 Z
MC 75	- 3 Z	VC 75	- 3 Z
MC 100	- 4 Z	VC 100	- 4 Z

FITTINGS			
Hose Tail + Pin Clamps (Spannfix)			
FEMALE		MALE	
MX 25	- 1 Z	VX 25	- 1 Z
	- 1.25 Z		- 1.25 Z
MX 32	- 1.25 Z	VX 32	- 1.25 Z
	- 1.5 Z		- 1.5 Z
MX 38	- 1.5 Z	VX 38	- 1.5 Z
	- 2 Z		- 2 Z
MX 50	- 2 Z	VX 50	- 2 Z
	- 2.5 Z		- 2.5 Z
MX 63	- 2.5 Z	VX 63	- 2.5 Z
	- 3 Z		- 3 Z
MX 75	- 3 Z	VX 75	- 3 Z
MX 100	- 4 Z	VX 100	- 4 Z

Hose Swivel

These Liquip Hose Swivels are typically used on overwing nozzles (i.e. the Liquip AVN040 / 042 overwing nozzles).

These swivels are nickel-plated brass. All threads are BSPP. A stainless steel version is available upon special request.

Ordering Information

Part No	Size
TS57-0026	1" M x 1" F
TS57-0058	1 1/2" M x 1 1/2" F
TS57-0054	2" M x 2" F
TS57-0059	1 1/4" M x 1 1/4" F
TS57-0005	2 1/2" M x 2 1/2" F



Gammon Hose Quick Disconnect

Fast change from Overwing to Underwing nozzle with no spill

FAST OPERATION Connect or disconnect in seconds, without tools. To connect, pull back sleeve, push connector into coupler and release sleeve. To disconnect, pull back coupler sleeve and connector halves separate. Valve opens automatically when halves are connected.

DEPENDABLE OPERATION The ball-lock mechanism is the simplest, most reliable type in use, providing positive connection under constant or surge flow - even excessive shock. Ball bearing sleeve lock permits 360 swivel action, preventing build-up of hose torque. Hardened stainless steel balls give extra long service. Stainless steel ball race resists wear for longer life.

Molded U-Packer seal provides contact over several times the normal O-ring sealing area. Its design embodies a self-energising feature that gives a positive seal at all pressures. This seal is capable of sealing under side loads and will tolerate small scratches and some dirt without leakage.

TIGHT SEAL DISCONNECT The poppet has a metal-to-metal stop to control compression on the valve o-ring seal. Seal is recessed and wedged in coupler body to keep it in place. The stop also prevents poppet blow-out.

LOW PRESSURE DROP DESIGN

1 1/2" size: 2.6 psi @ 189.3 lpm
2" size: 2.9 psi @ 379.5 lpm

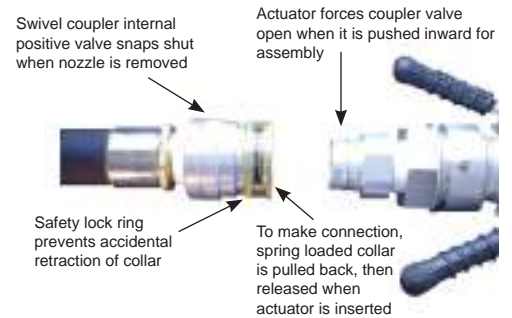

All couplers and actuators are made of aluminium, unless stated otherwise. **NOT** designed for suction service.

Ordering Information

Part No	Size
8732	Coupler 1 1/2" BSP Female
8733	Actuator 1 1/2" BSP Male
8734	Dust Cap to suit Actuator
GTP-1506-40	Seal Kit suit 8732 Coupler

N.B. For all other sizes, please contact our sales department



Hose Beads

Increase the life of your aviation hose

Replacing aviation hose can be costly. Fitting hose beads saves the hose from rubbing along the tarmac, minimising wear and abrasion damage. The bead allows for relatively effortless manoeuvring of the hose and also acts as a hose marker at night.

The 2-piece yellow plastic beads bolt or clip together around the hose and Liquip suggest a bead is fitted every 700 mm run of hose.

Pending conformance with EI 1522. Contact Liquip for further details.



Spacings

20 metre Hose	Reel gooseneck to first bead centre	Hose bead spacing (centre-centre)	Last bead centre to nozzle	Qty of beads / 20m
Recommended	3m	700 mm	1.5 m	32

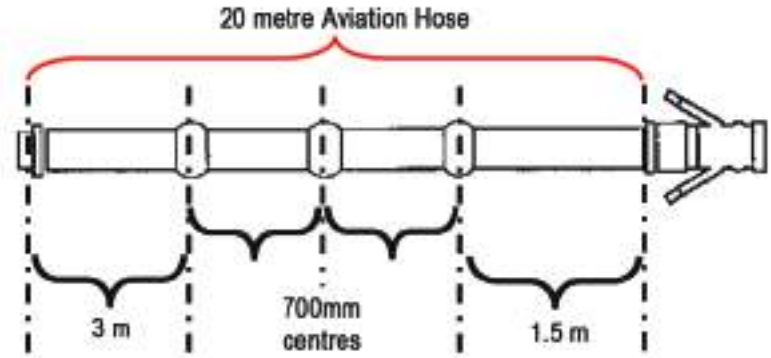

Ordering Information

Part No	Size	Type
HB1.25Z	suit 32mm ID hose	Screw
HB1.5	suit 38mm ID hose	Screw
HB38-CLICK	suit 38mm ID hose	Click
HB50	suit 50mm ID hose	Screw
HB2.5Z	suit 63mm ID hose	Screw
CHA100-1Z	suit 4" code hose	Screw



Hose Reflective Cover

Be Seen! Be Safe!

Liquip Input Hose Covers help prevent incidents occurring around dispenser inlet hoses, particularly during night refuelling. The “Flame Orange” reflective material with two yellow stripes ensure increased visibility. Installation and removal is easy as the covers are fastened using Velcro.

Ordering Information

Part No	Size
9485	Suit 4" ID hose
On request	Suit 3" ID house



Aviation Hosereel Drum Style - HP Series

High pressure hose reel suitable for petroleum products

The HP series of hose reels are a generation of reels for high pressure use and available with hand or hydraulic rewind and in different sizes. Sealing is by lip seal and all models incorporate a lock assembly. Ball bearings look after rotation, with end thrust being taken care of by heavy-duty circlips and thrust washers. All components are easily replaced and all wetted surfaces are nickel plated for longer life.

Stainless steel inlet flange, nickel plated gooseneck with 1 1/4" MBSP.

Technical Specifications

Sizes	Hose size - 25mm, 32mm and 38mm diameter Rewind type - Manual or hydraulic Drum width - 300mm, 450mm or 600mm Anti-rotation lock to prevent hose unravelling
Pressure	Rated to 2100 kPa
Servicing	Quarterly grease plumber block bearing Annually remove and repack bearing on the inlet side of the reel
Mounting	4 x M10 bolts
Materials	Stiffened steel cheek plates, extremely sturdy thick wall manifold with added strength from steel inner drum, steel base frame and self aligning bearing. Polyurethane seals.
Options	Hot dip galvanised version 1 1/2" N/P FBSP gooseneck Rollers and guides



Aviation Hosereel Drum Style - HPNP Series

Ordering Information

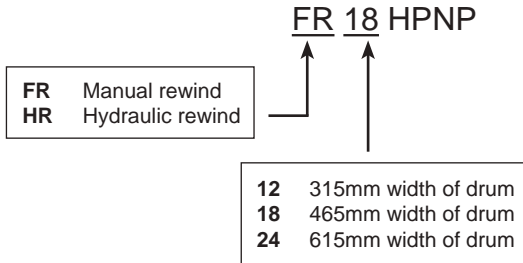

NOTE: Electric made available on request
(Refer to Hosereels Assemblies)

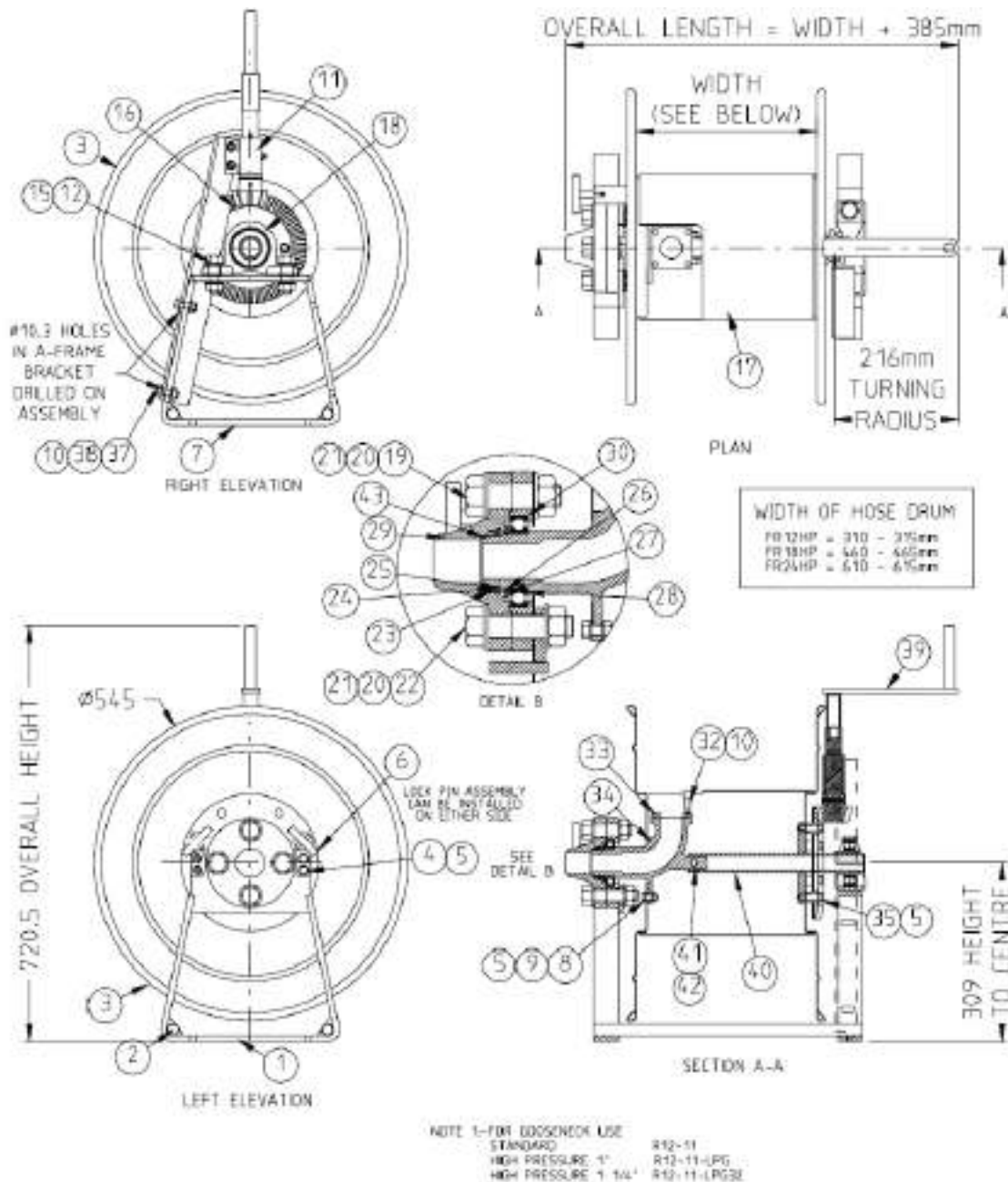

Aviation Hosereel Drum Style - HPNP Series

HPNP Hosereel Parts List

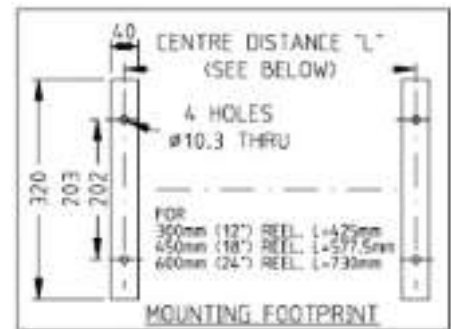

Parts that differ only shown

Item	FR12HP	FR18HP	FR24HP	Description	Material	Qty
	Part No	Part No	Part No			
1	R12HP-7	-	-	A Frame and Bearing Mounting Bracket Assembly	Mild Steel	1
2	R12HP-33	R18HP-33	R24HP-33	A Frame Spacer Bar	Mild Steel	2
3	R12HP-8	-	-	Hosereel End Spinning	Mild Steel	2
4	0011	-	-	Bolt Hex Head	M/Steel Z/P	3
5	0108	-	-	Washer Spring	M/Steel Z/P	11
6	R12HP-10	-	-	Lock Pin Assembly	Mild Steel	1
7	R12HP-6	-	-	A Frame Bearing Side	Mild Steel	1
8	0012	-	-	Bolt Hex Head	M/Steel Z/P	3
9	0149	-	-	Nut Nyloc	M/Steel Z/P	3
10	0109	-	-	Washer Spring	M/Steel Z/P	6
11	FR12HP-23	-	-	Front Rewind Bracket Assembly	M/Steel Z/P	1
12	4803	-	-	Bolt Hex Head	M/Steel Z/P	2
13						
14	R12-11	-	-	Gooseneck Assembly 1 1/2" BSPT Male	M/Steel	1
15	0154	-	-	Nut Nyloc	M/Steel Z/P	2
16	FR12-5	-	-	Crown Gear	Aluminium	1
17	R12-32	R18-32	R24-32	Hose Drum	M/Steel	1
18	4523	-	-	Bearing Pillow Block	HT/Steel	1
19	4810	-	-	Bolt Hex Head	M/Steel Z/P	1
20	4345	-	-	Washer Spring	M/Steel Z/P	4
21	0799	-	-	Nut	M/Steel Z/P	4
22	0876	-	-	Bolt Hex Head	M/Steel Z/P	3
23	4516	-	-	Seal U Style	Polyurethane	1
24	R12HP-9	-	-	Ring Backing Seal	M/Steel Z/P	1
25	4339	-	-	Circlip Internal	HT/Steel	1
26	4338	-	-	Circlip External	HT/Steel	1
27	R12HP-22	-	-	Ring Backing Bearing	M/Steel Z/P	1
28	4515	-	-	Bearing Deep Groove Ball	HT/Steel	1
29	R12HP-13	-	-	Retainer Seal	M/Steel Z/P	1
30	R12HP-12	-	-	Retainer Bearing	M/Steel Z/P	1
31						
32	0719	-	-	Capscrew	M/Steel Z/P	4
33	0664	-	-	Gasket	Neo-Cork	1
34	R12-36	-	-	Manifold	SG Iron	1
35	0015	-	-	Setscrew Hex Head	M/Steel Z/P	6
36	0715	-	-	Capscrew	M/Steel Z/P	2
37	0022	-	-	Setscrew Hex Head	M/Steel Z/P	2
38	0130	-	-	Nut	M/Steel Z/P	2
39	R12-26	-	-	Rewind Handle Assembly	Mild Steel	1
40	R12HP-11	R18HP-11	R24HP-11	Bearing Support Pipe	Mild Steel	1
41	4879	-	-	Bolt Hex Head	M/Steel Z/P	1
42	4981	-	-	Nut Nyloc	M/Steel Z/P	1
43	4547	-	-	O-Ring	Viton	1
44	4549	-	-	Seal U Style	Nitrile	Optional

Aviation Hosereel Drum Style - AHR Series

Drum style hose reel suitable for aviation fuels

A convenient method of storing a quantity of fuel delivery hose. When the fill point is located at varying location the required length of hose can be dispensed and rewound by electric, hydraulic or manual means.

Liquip's sturdy aluminium AHR250D Drum style hose reel range adapts to a variety of drive mechanisms.

EASY OPERATION Just unhook nozzle and dispense hose to the required location. To rewind hose a manual handle, electric motor or hydraulic motor is used. The hose nozzle storage can be fitted with interlocks to help prevent drive away accidents and product spills.

Technical Specifications

Sizes	Hose size - 1", 1 1/4", 1 1/2", 2" & 2 1/2" Rewind type - Manual, electric or hydraulic Drum width - 300mm, 450mm, 600m or 950mm An optional A-Frame is available.
Pressure	Rated to 2100 kPa
Servicing	Annually remove and repack bearings on each side of the reel
Mounting	4 x M12 bolts Inlet flange is to suit 75mm (3") TTMA - 8 off 3/8" BSW x 25mm deep blind threads on a 124mm PCD



Aviation Hosereel Drum Style - AHR Series

Ordering Information

AHR250D - 50 - M - 60

38 - 1 1/2" BSPP Gooseneck
50 - 2" BSPP Gooseneck
63 - 2 1/2" BSPP Gooseneck

30 - 300mm Hose Drum Width
45 - 450mm Hose Drum Width
60 - 600mm Hose Drum Width
95 - 950mm Hose Drum Width

M - Manual Rewind
H - Hydraulic Rewind
E - Electric Rewind

NOTE: Electric available as an assembly

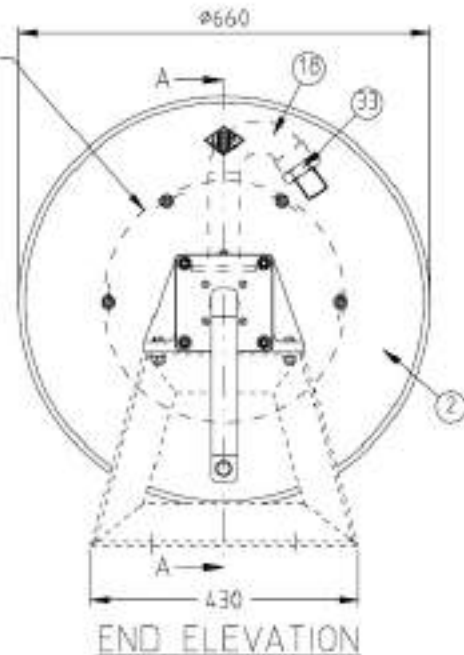
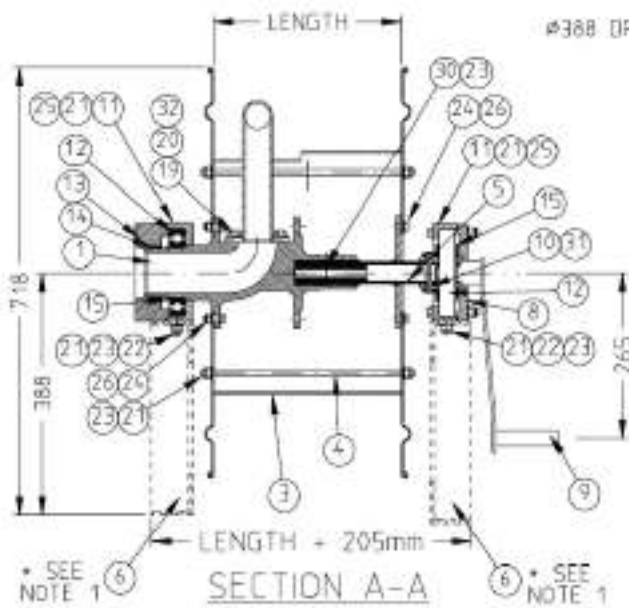
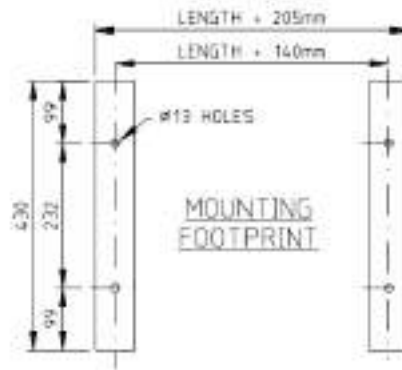
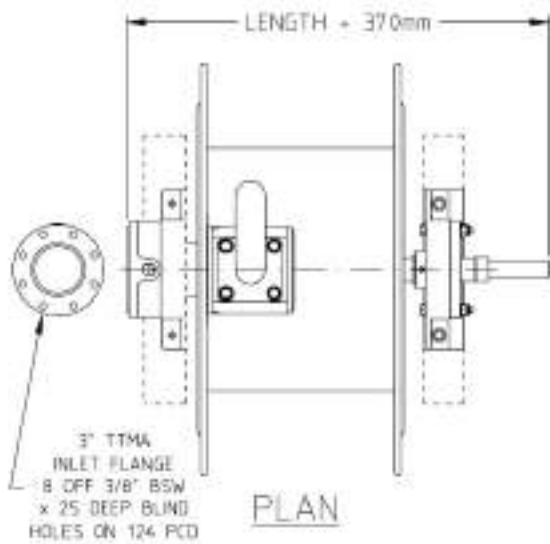

Aviation Hosereel Drum Style - AHR Series

AHR250D Hosereel Parts List

Item	Part No	Description	Material	Qty
1	AHR250-1	Manifold Hosereel	Aluminium	1
2	AHR250D-2	Cheekplate	Aluminium	2
3a	AHR250D-3-30	Drum (300mm wide)	Aluminium	Table
3b	AHR250D-3-45	Drum (450mm wide)	Aluminium	Table
3c	AHR250D-3-60	Drum (600mm wide)	Aluminium	Table
3d	AHR250D-3-95	Drum (950mm wide)	Aluminium	Table
4a	AHR250D-4-30	Tie Rod (340mm long)	Steel	Table
4b	AHR250D-4-45	Tie Rod (490mm long)	Steel	Table
4c	AHR250D-4-60	Tie Rod (640mm long)	Steel	Table
4d	AHR250D-4-95	Tie Rod (990mm long)	Steel	Table
5a	AHR250D-5-30	Shaft Extension (262mm long)	Steel	Table
5b	AHR250D-5-45	Shaft Extension (412mm long)	Steel	Table
5c	AHR250D-5-60	Shaft Extension (562mm long)	Steel	Table
5d	AHR250D-5-95	Shaft Extension (912mm long)	Steel	Table
6	AHR250D-6	A-Frame (Inlet Side)	Steel	Option
8	AHR250-13	Mounting Plate	Aluminium	1
9	AHR250D-9	Rewind Handle	Steel	Table
10	AHR250-19	Adaptor Bearing	Aluminium	1
11	AHR250-2	Bearing Housing	Aluminium	2
12	5715	Ball Bearing	Steel	2
13	AHR250-3	Seal Housing	Aluminium	1
14	0127	O-Ring	Viton	2
15	4585	Circlip	Steel	2
18a	AHR250D-6-38	Gooseneck 38mm	Steel	Table
18b	AHR250D-6-50	Gooseneck 50mm	Steel	Table
18c	AHR250D-6-53	Gooseneck 63mm	Steel	Table
19	0022	Setscrew	Steel	4
20	0109	Washer Spring	Steel	4
21	0102	Flat Washer	Steel	36
22	0062	Bolt	Steel	4
23	0150	Nut Nyloc	Steel	25
24	0011	Setscrew	Steel	12
25	0031	Bolt	Steel	8
26	0101	Washer Flat	Steel	12
30	0066	Bolt	Steel	1
31	6676	Spring Pin	Steel	1
32	4281	Gasket Gooseneck 1.6mm Thick	Klingerite	1
33a	AHR250D-15	Nipple Reducing 1 1/2" BSP to 1" BSP	Steel	Table
33b	AHR250D-16	Nipple Reducing 1 1/2" BSP to 1 1/4" BSP	Steel	Table
33c	AHR250D-17	Nipple Straight 1 1/2" BSP	Steel	Table

Aviation Hosereel Cartwheel Style - AHR Series

Cartwheel style hosereel suitable for aviation fuels

The AHR250 series covers a large number of sizes, variations and options.

Generally the reel is available in either open frame design or with side infill panels. The reels are available in various diameters and widths to accommodate a large range of hose diameters and lengths, with or without hose beads / protection rings.

A typical complete assembly also incorporates a hose guide or “chute” and nozzle stowage, to which interlocks are usually added to help prevent drive away accidents and product spills. Rewind options are hydraulic motor, electric motor or hand / manual rewind.

EASY OPERATION Just unhook nozzle and dispense hose to the required location. To rewind hose a manual handle, electric motor or hydraulic motor is used. The hose nozzle storage can be fitted with interlocks to help prevent drive away accidents and product spills.

Technical Specifications

Sizes	Hose size - 1", 1 1/4", 1 1/2", 2" & 2 1/2" nominal bore Rewind type - Manual, electric or hydraulic Cartwheel lining for hoses with wear beads. Please refer to ordering information for more options. Custom design is available.
Pressure	Rated to 2100 kPa
Servicing	Annually remove and repack bearings on the inlet side of the reel
Mounting	Support frame not supplied. Inlet flange is to suit 75mm (3") TTMA - 8 off 3/8" BSW x 25mm deep blind threads on a 124mm PCD
Weight	37kg
Materials	Aluminium cart wheels and drum, nickel plated steel gooseneck and viton seals



Aviation Hosereel Cartwheel Style - AHR Series

Ordering Information

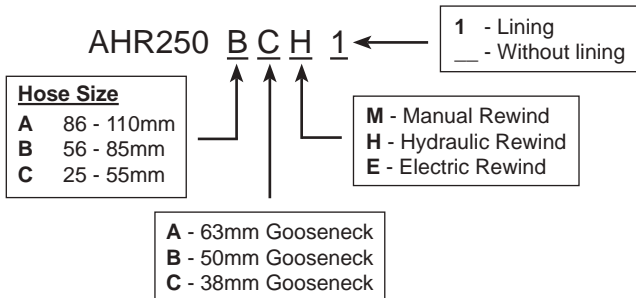

NOTE: Electric available as an assembly

AHR250A Hosereel suits hose sizes from diameter 86mm to 110mm and will accept 2" (50mm) and 2 1/2" (63mm) hoses with hose beads

AHR250B Hosereel suits hose sizes from diameter 56mm to 85mm and will accept 1 1/4" (32mm) and 1 1/2" (38mm) hoses with hose beads, or 2" (50mm) and 2 1/2" (63mm) hoses without hose beads

AHR250C Hosereel suits hose sizes from diameter 25mm to 55mm and will accept 1 1/4" (32mm) and 1 1/2" (38mm) hoses without hose beads

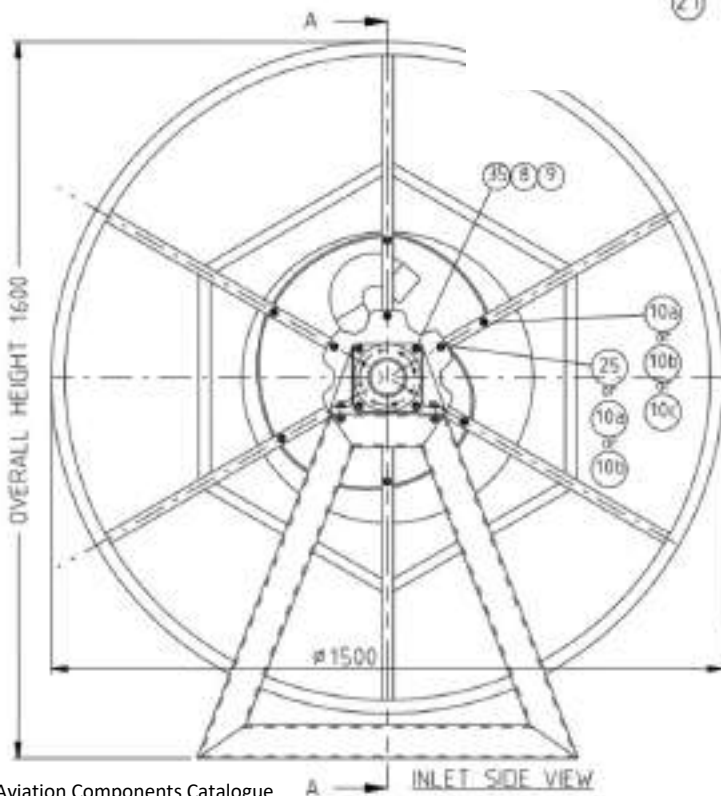
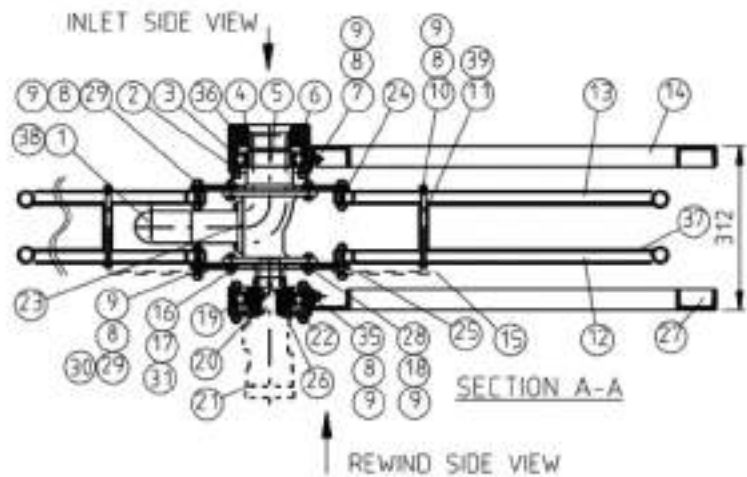
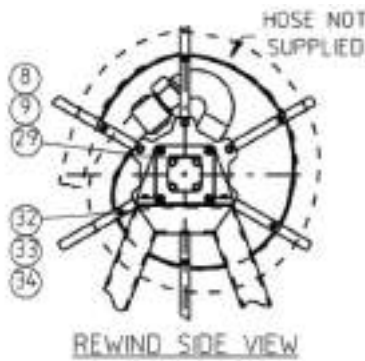

AHR250A
SUIT HOSE SIZES
#86mm - #110mm

AHR250B
SUIT HOSE SIZES
#56mm - #85mm

AHR250C
SUIT HOSE SIZES
#25mm - #55mm

SOLD PARTLY ASSEMBLED
TO MAKE RIGHT HAND
REMOVE CARTWHEELS,
TURN MANFOLD ONLY 180°
AND REPLACE CARTWHEELS
(GOOSENECK & CARTWHEELS
REMAIN THE SAME)

Aviation Hosereel Cartwheel Style - AHR Series

AHR250 Hosereel Parts List

Item	Part No	Description	Material	Qty AHR250A	Qty AHR250B	Qty AHR250C
1a	AHR250-6	Gooseneck 2 1/2" BSPP (63mm dia hose)	Steel	1	-	-
1b	AHR250-6-50	Gooseneck 2" BSPP (50mm dia hose)	Steel	-	1	-
1c	AHR250-6-38	Gooseneck 1 1/2" BSPP (25-38mm dia hose)	Steel	-	-	1
2	AHR250-2	Bearing Housing	Aluminium	2	2	2
3	5715	Ball Bearing	-	2	2	2
4	0127	O-Ring	Viton	2	2	2
5	AHR250-1	Manifold	Aluminium	1	1	1
6	AHR250-3	Seal Housing	Aluminium	1	1	1
7	0062	Bolt Hex Head	Steel	4	4	4
8	4392	Nut Half Nyloc	Steel	30	30	30
9	0102	Flat Washer	Steel	64	64	64
10a	AHR250-35	Bolt Special 195mm long	Steel	6	1	-
10b	4907	Bolt Hex Head	Steel	-	6	1
10c	0059	Bolt Hex Head	Steel	-	-	6
11a	AHR250-39A	Snail Drum 110mm wide	Aluminium	1	-	-
11b	AHR250-39B	Snail Drum 80mm wide	Aluminium	-	1	-
11c	AHR250-39C	Snail Drum 55mm wide	Aluminium	-	-	1
12	AHR250-9	Cartwheel Assembly (Right Hand)	Aluminium	1	1	1
13	AHR250-9	Cartwheel Assembly (Left Hand)	Aluminium	1	1	1
14	-	Right Side Support	Steel	1	1	1
15	1261	Sprocket	Steel	Not Supported		
16	0056	Setscrew Hex Head	Steel	12	12	12
17	0149	Nut Nyloc	Steel	12	12	12
18	0022	Setscrew	Steel	4	4	4
19	AHR250-19	Adaptor Bearing - Hyd Drive	Aluminium	1	1	1
20	AHR250-11	Adapting Bush	Steel	1	1	1
21*	1295	Hydraulic Motor Danfoss Hosereel	-	Not Supported		
22	AHR250-13	Hydraulic Motor Mounting Plate	Aluminium	1	1	1
23	4281	Gasket	Klingerite	1	1	1
24a	AHR250-5	Cast Aluminium Cheek Plate	Aluminium	-	2	-
24b	AHR250-8	Cast Aluminium Cheek Plate - Offset	Aluminium	2	-	2
25	AHR250-36	Bolt Special 225mm long	Steel	1	-	-
26	6676	Pin Selox	Steel	1	1	1
27	-	Left Side Support	Steel	1	1	1
28	0109	Washer Spring	Steel	4	4	4
29	0025	Setscrew Hex Head	Steel	12	12	12
30	4995	Setscrew Hex Head	Steel	Not Supported		
31	0101	Washer Flat	Steel	24	24	24
35	0031	Bolt Hex Head	Steel	8	8	8
36	4585	Circlip External	-	2	2	2
37	AHR250-34	Cartwheel Lining (optional)	Aluminium	4	4	4
38a	0439	Nipple Reducing 1 1/2" BSP x 1 1/4" BSP Hexagon	Steel	-	-	As Req'd
38b	0445	Nipple Reducing 1 1/2" BSP x 1" BSP Hexagon	Steel	-	-	As Req'd
38c	0472	Nipple 1 1/2" BSP Hexagon	Steel	-	-	As Req'd

* For Hydraulic Rewind Only. Must be ordered separately
Issue 10 - Aviation Components Catalogue

Hosereel Assemblies - Electric Rewind

Designed for ease of operation in a dangerous environment

Design and custom built hosereel assemblies using electric rewind mechanisms.

These are designed to electrically rewind aviation hose safely in a dangerous environment. This unit will require the operator to provide significantly less force in unwinding the hose than any of its chain driven predecessors, thus significantly reducing the potential for back injury to the operator.

Operation of the unit is simply a matter of pushing the start/stop switch to rewind the hose. The ramp up feature on the inverter allows the motor some time to go from rest to full speed, so fine control is available over the final portion of the hoses journey by toggling the switch to "inch" the hose in.



Features

- The frame is fabricated from steel, is hot dip galvanised and designed to accommodate all components.
- Drive is provided by a 3 Phase, 1.1Kw, Class 1, Zone 1 explosion proof ex-d electric motor and runs through a single-to-three phase variable speed inverter. This provides greater flexibility in speed control. The unit is preset by Liquip. It is capable of "ramping up" to operating frequency, and "ramping down" from operating frequency. These parameters are completely controllable via the keypad located on the front of the inverter.
- Power is transmitted to the reel by an anti-static timing belt. This eliminates the need for a chain drive; therefore no metal-to-metal contact is present. This eliminates the possibility of a spark caused by chain lash etc.
- The anti-static belt eliminates the potential for static caused by belt slippage or sideways float. The belt is tensioned automatically by a spring-loaded tensioner, eliminating the need for constant adjustments.
- To minimise the possibility of catching fingers in the belt drive, the unit may be purchased specifying either a hinged full cover or a belt guard. The hinged cover features a polycarbonate window in the top, and hose roller guides in the front. It covers the entire unit when lowered. The belt guard is a removable profiled guard designed to sit over the driven sprockets and the timing belt. The rest of the unit remains uncovered.



Ordering Information

Contact Liquip for custom build information

Hosereel Assemblies - Electric Rewind

Ordering Information

CART WHEEL STYLE

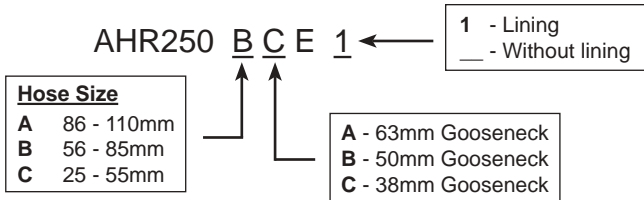

DRUM STYLE

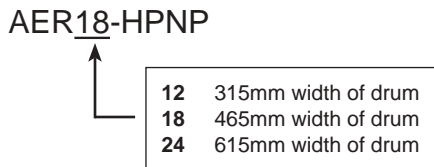

Contact Liquip for custom build ordering information.

Large diameter cartwheel hosereels for single wrap hoses with or without hose beads. 38mm or 50mm male BSP thread for hose connection. Check plate diameter made to order, customer to specify required hose size and length and our Engineering Department will specify the right size reel to suit.

Note: The drive for these units will be a 3 phase 1.1kW, Class 1, Zone 1 explosion proof ex-d electric motor driving a hydraulic pump with its own hydraulic reservoir and check valve. This will in turn drive a hydraulic motor via a pressure and return line to the pump.





Nozzles & Accessories

OPW 295SA & SAJ Aircraft Nozzles

The OPW 295SA and SAJ Aircraft Nozzles are used for overwing aircraft refuelling.

Features & Benefits

- Aluminum Body – lighter weight, easier to maneuver.
- Dual Poppets – easy-to-open nozzle against high inlet pressures.
- Color-Coded Composite Lever Guards – helps distinguish between AVGAS and Jet A. Easily replaced in lever guard kit.
- Vinyl-Coated Lever – insulates fingers against cold.
- Dust Cap – keeps spout free from dirt and stops fuel drippage when connected.
- Adjustable Dash Pot – permits adjusting the main poppet closure rate over a wide range of flows to overcome line shock with minimum afterflow.
- Right Angle Design – provides larger lever area for better grip and easier control.
- Easily replaced spout – the spout is easily threaded into the body. Replacement spouts are readily available from OPW.
- Built-In Swivel – eliminates twisting and kinking of the hose. This swivel is electroless nickel-plated and has full-bearing surfaces.
- Unique Jet Aircraft Spout Design of 295SAJ – to help prevent inadvertent fueling of piston engine aircraft with turbine fuel.
- Ground Wire Assembly – included on all aviation nozzles.

Technical Information

Materials

Body: Cast aluminum
Main Stem: Stainless steel
Stem Seal: Buna-N O-Ring
Disc: Viton®
Spout: Aluminum

Design working pressure

110 psi (7.58 bar) maximum pressure.

Threads

NPT Female Threads at Inlet End of 295SA – accepts all 1”, 1-1/4” or 1-1/2” male connections.

NPT Female Threads At Inlet End Of 295SAJ – accepts all 1-1/2” male connections.

Strainer

100 Mesh Strainer – prevents foreign matter from entering fuel tank; easy to remove and clean.

Ordering Information

Part No.	Inlet Thread			Spout O.D		
	in.	mm	lbs.	kg	in.	mm
295SA-0135	1	25	4.6	2.1	1	25
295SA-0136	1¼	32	4.5	2	1	25
295SA-0137	1½	38	4.5	2	1	25
295SA-0138	1½	38	5.1	2.3	1½	41
295SAJ-0200	1½	38	5.6	2.5	2½	54
295SAC-0156*	1¼	32	4.5	2	1	25
295SAC-0157*	1½	38	4.5	2	1	25
295SAC-0158*	1½	38	5.15	2.3	1½	41
295SACJ-0200*	1½	38	5.65	2.6	2½	54

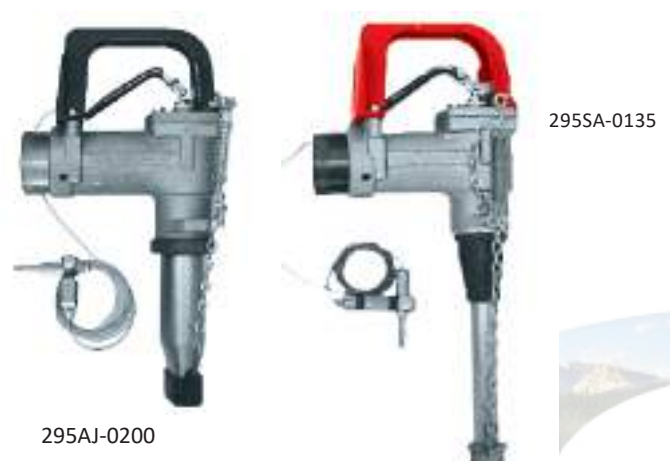

*Check Valve

Issue 10 - Aviation Components Catalogue

www.liquip.com

Elaflex Bowser Nozzle

The ZVF25 1" refuelling nozzle has been the bench-mark nozzle for aviation refuelling for decades. With an internal check valve, 100 mesh strainer and integral inlet swivel.

- Maximum flow rate: 140 litres / minute
- Working pressure: up to 3.5 bar (50 psi)
- Spout: 27 Ø - 1" BSP female inlet
- Operation: Manual shut-off
- Materials: Aluminium body, guard and inlet swivel, stainless steel and acetal internals, Nitrile and Vulkollan seals

Ideal for fuels up to 50% aromatics, alcohols up to 15%, Jet fuels and Diesel
(NOT suitable for viscous oils)



Ordering Information

Complete Nozzle	
Part No	Description
ZVF25.41	Includes dust cap & spring loaded chain, swivel, strainer and 1.2m bonding cable & clip

Spare Parts	
Part No	Description
EA075.1	Inlet swivel
ES336.1	Strainer (100 mesh)
GKG25	Dust cap & spring loaded chain
EKG1200	Bonding cable (1.2m) and clip

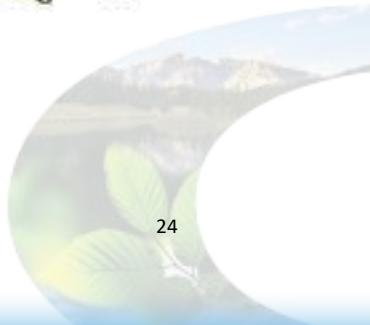
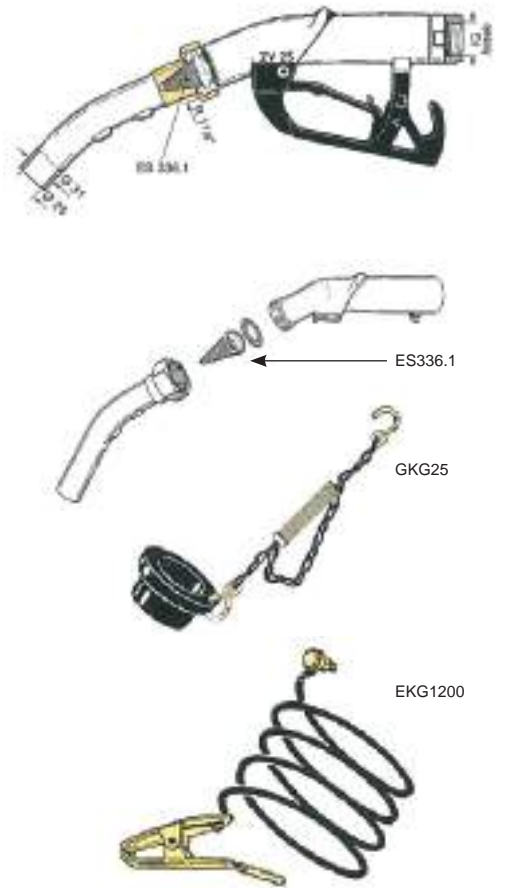

AVN042 Aviation Overwing Fuelling

The Liquip AVN042 has been designed as an easily operated nozzle for (overwing) delivery of aviation fuels. Unlike normal nozzles, it is equipped with “power assist” dashpot operation, making it as light as a service station bowser nozzle. The body, handle and trigger are made from heavy duty, lightweight aluminium. The handle and trigger are easily replaceable and the body has wear ribs to protect when dragged.



- The Spout Adaptor will accept any of the four (4) available spouts.
- Optional Inlet Swivel.
- Seals are compatible with all Jet and aviation fuels.
-

Operation

Pressure-balance design provides for small and constant finger force on the trigger regardless of the pump pressure. The Trigger opens a valve in order to deliver product. The bullet-shaped internal seal opens first, allowing the pressure inside the nozzle to equalise, making it easy to then open the product seal. Such ease of operation permits accurate, fine top-up without any surging and splashing.

Technical Data

- SPECIFICATIONS:** Trigger force constant 60N at midpoint.
38mm (1 ½”) diameter flow through.
Only 50kPa pressure drop at 300 L/min with 32mm spout.
- WEIGHT:** 2.5kg with 32mm spout.
- MOUNTING:** 38mm (1½” BSPP female thread) inlet.
- MATERIALS:** Aluminium body, handle, trigger and adaptor outlet.
Stainless Steel shaft, pin and spring.
Viton and Polyurethane seals.
- DISMANTLING:** Remove capscrew (item 13), unscrew outlet adaptor (item 12). This will give access to all internals.
- ADJUSTMENT:** None.
- ASSOCIATED EQUIPMENT:** See next page.

Ordering Information

PART NO:	DESCRIPTION
AVN042	Aviation Overwing Fuelling Nozzle

AVN042 Aviation Overwing Fuelling

AVN042 FUELLING NOZZLE

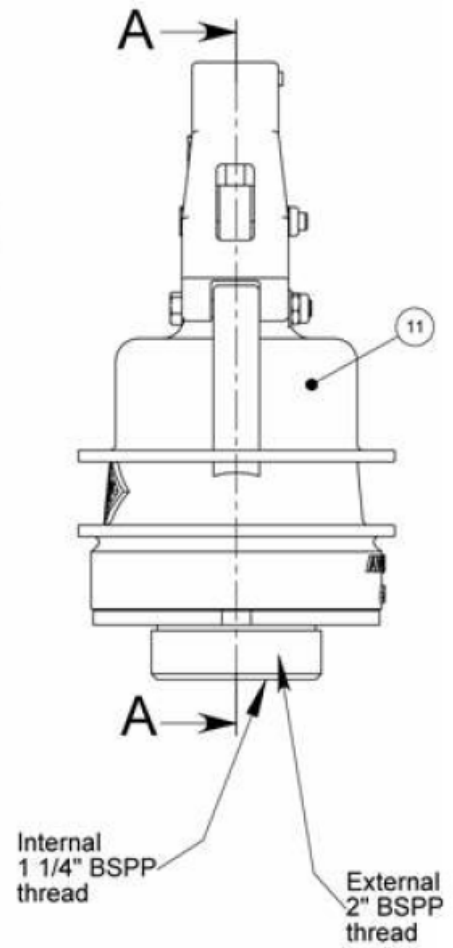
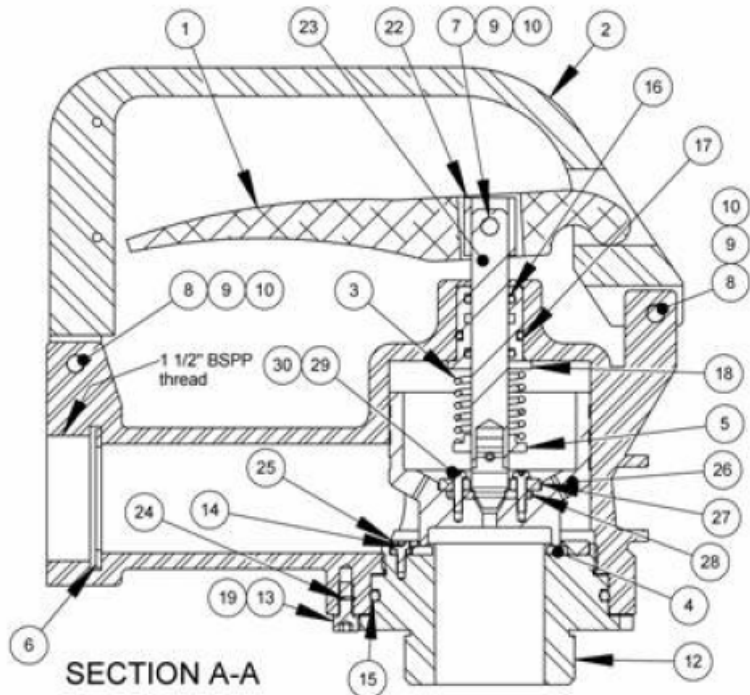

ITEM	PART No	DESCRIPTION	Default /QTY.	MATERIAL
1	AVN040-5	TRIGGER NOZZLE	1	ALUMINIUM
2	AVN040-4	HANDLE	1	ALUMINIUM
3	6152	COMPRESSION SPRING	1	ST STEEL
4	7517	SEAL PRODUCT OUTLET	1	VITON
5	AVN030-8	RETAINER SPRING NOZZLE	1	ALUMINIUM
6	GD38	SEAL INLET NOZZLE	1	POLYURETHANE
7	6617	BOLT METRIC	1	STEEL
8	6603	BOLT METRIC	2	STEEL
9	5267	WASHER FLAT	3	STEEL
10	4400	NUT HALF NYLOC	3	STEEL
11	AVN040-1	BODY NOZZLE	1	ALUMINIUM
12	AVN040-9	ADAPTOR FOR SPOUT NOZZLE	1	ALUMINIUM
13	0704	CAPSCREW METRIC	1	STEEL
14	6602	CAPSCREW METRIC	3	ST STEEL
15	3042	O-RING	1	VITON
16	0244	O-RING	2	VITON
17	0278	O-RING	1	VITON
18	ARO100-4	AIR RAM SHAFT BUSH	1	ACETAL
19	6498	WASHER SPRING	1	STEEL
20	7940	CAP	1	PVC
21	5695	CAP	1	PVC
22	7233	DAMPENER RUBBER	1	NEOPRENE
23	AVN042-10	SHAFT AND TIP ASSY	1	ST STEEL/ACETAL
24	3360	LOCTITE	1	LOCTITE
25	AVN040-6	RETAINER SEAL NOZZLE AVIATION	1	ALUMINIUM
26	AVN040-3	PISTON NOZZLE	1	ALUMINIUM
27	AVN042-1	RETAINER FOR SEAL	1	ALUMINIUM
28	7556	SEAL IN POPPET	1	VITON
29	6526	SCREW METRIC	4	ST STEEL
30	6527	WASHER SHK-PRF INT	4	ST STEEL

X201005
Issue: C

AVN042 Aviation Overwing Fuelling

Accessories

Part No: AVN042

SPOUTS

- ER250 25mm (reduced) spout
- ER495 32mm aluminium spout
- ER583 38mm aluminium spout
- ER587-JET Jet-Selective aluminium spout

DUST CAPS

- GKG25 Buna-N dust cap & spring loaded chain suit 25mm spout
- GKG32 Buna-N dust cap & spring loaded chain suit 32mm spout
- GKG38 Buna-N dust cap & spring loaded chain suit 38mm spout
- GKG38-J Buna-N dust cap & spring loaded chain suit Jet Selective spout

ADAPTOR

- EK432 Brass adaptor to suit AVN040 o/w nozzle for fitting spouts.

STRAINER

- ES418 Poly / stainless steel 100 mesh strainer suit EK432 adaptor

SPLASH GUARD

- EK419 Buna-N guard suit EK432 adaptor

STATIC CLAMPS

- EKG1200 Clamp & Lead



AVN042 Aviation Overwing Fuelling

Ordering Information

Ordering the Complete Nozzle:

Part No	Spout Size
AVN-25Z	25mm
AVN-32Z	32mm
AVN-38Z	38mm
AVN-JZ	Jet Selective

* Complete nozzle does not come with swivel

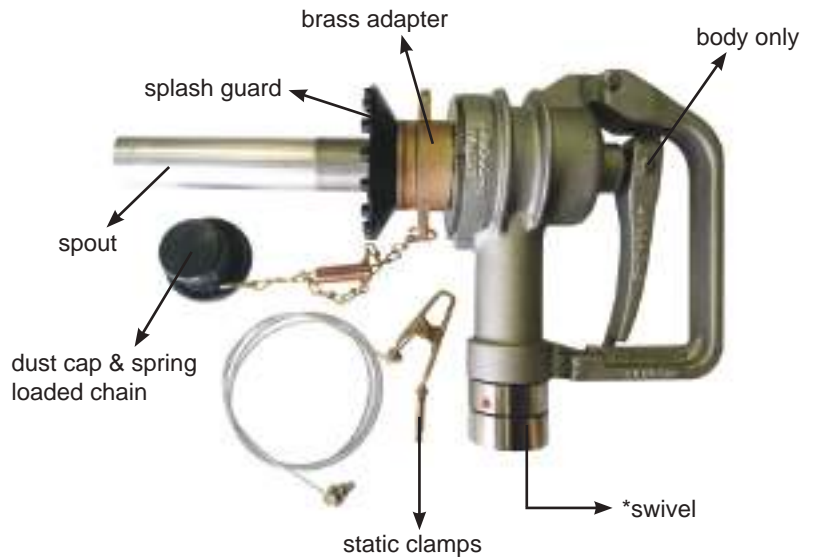

Ordering Accessories

NOZZLE BODY ONLY

AVN042

SPOUTS

- ER250 25mm (reduced) spout
- ER495 32mm aluminium spout
- ER583 38mm aluminium spout
- ER587 JET Jet-Selective aluminium spout

DUST CAPS

- GKG25 Buna-N dust cap & spring loaded chain suit 25mm spout
- GKG32 Buna-N dust cap & spring loaded chain suit 32mm spout
- GKG38 Buna-N dust cap & spring loaded chain suit 38mm spout
- GKG38-J Buna-N dust cap & spring loaded chain suit Jet Selective spout

ADAPTOR

- EG432 Brass adaptor to suit AVN042 o/w nozzle for fitting spouts

STRAINER

- ES418 Poly / stainless steel 100 mesh strainer suit EK432 adaptor
- EG-ASS (Adaptor EG432 + Strainer ES418)

SPLASH GUARD

- EK419 Buna-N guard suit EG432 adaptor

STATIC CLAMPS

- EKG1200 1.2m bonding cable and clip



Nozzle Stowage

The Liquip Aviation Nozzle Stowages are used on virtually all Liquip aircraft refuelling vehicles as well as other non-vehicle or stand-alone aviation fuelling applications.

Ball & Socket - Underwing

The Liquip ball and socket nozzle stowage assembly provides safe and sturdy nozzle storage as well as an interlocking mechanism. The interlocking mechanism can be connected to either an electrical interlock switch or a pneumatic interlock valve.

Releasing a nozzle from the socket is made easy using a lever located directly under the socket. This assembly consists of an anodised aluminium alloy body and stainless steel ball to minimise the chance of sparking on contact.

Ordering Information

Item No	Part No	Description
1	4600-06-01	Interlock Handle only
2	4600-05-01	Interlock Ball only
3	8568	Plunger Interlock Switch
4	4600-05-00	Interlock Ball & Socket Assembly
5	4600-01-01	Nozzle Holder
6	4600-04-01	Nozzle Holder

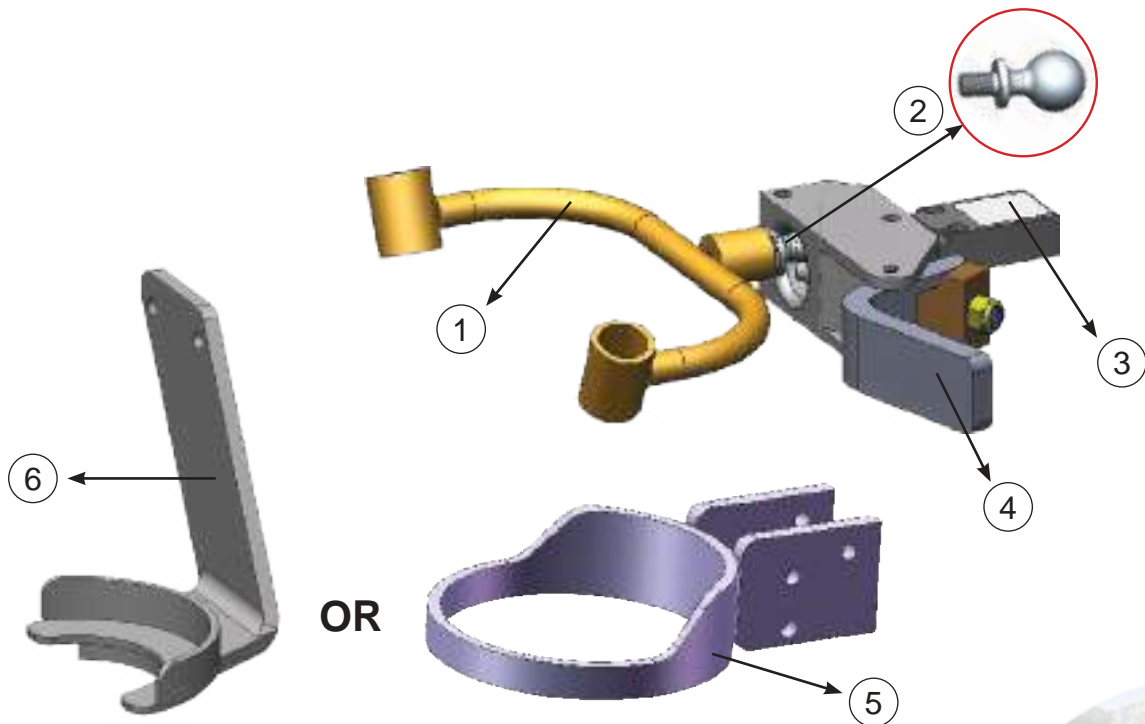

Nozzle Stowage

Ball & Socket - Overwing

Ordering Information

Item No	Part No	Description
1	4600-03-02	Nozzle Stowage Cover
2	4600-03-06	Jet Selective Nozzle Stowage
3	4600-06-02	Overwing Nozzle Interlock Bracket
4	4600-03-01	Nozzle Stowage Holder Assembly

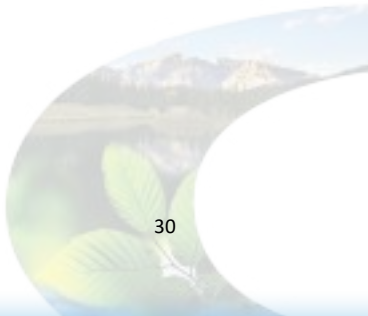
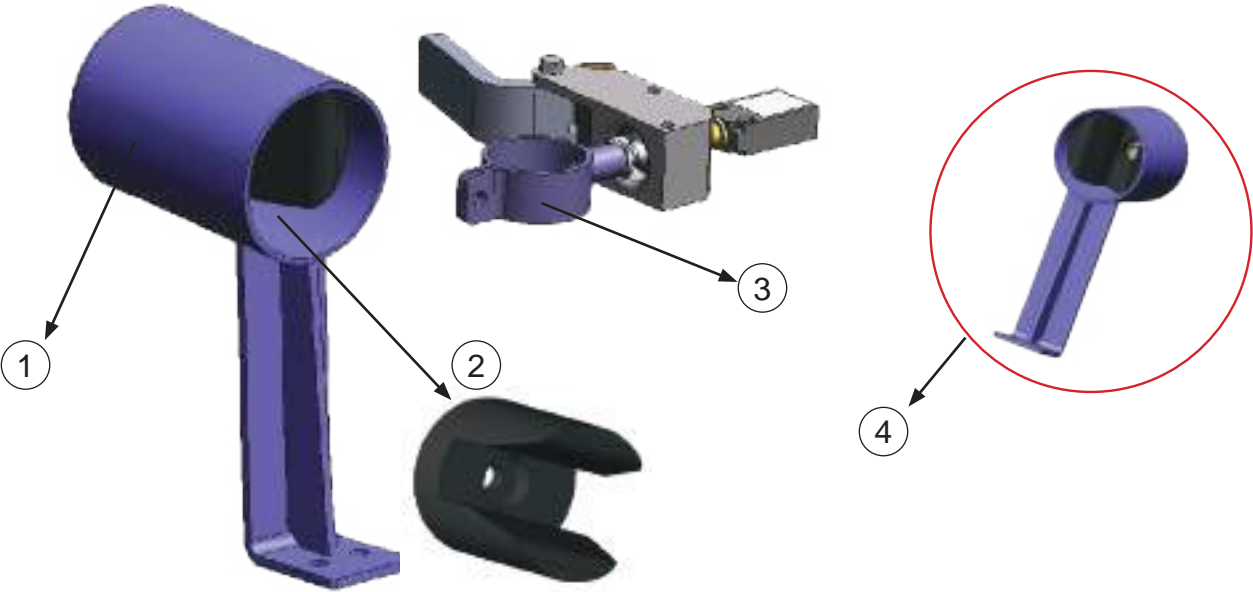

Nozzle Stowage

Twist-Lock Bayonet

A 'cup stowage with "twist-lock" bayonet adaptor" is a recent variant.

Ordering Information

Item No	Part No	Description
1	4600-01-07	Bucket Style Nozzle Stowage
2	20216201F	Twist-lock Bayonet Adaptor
3	8568	Plunger Interlock Switch (Ex'd Rated)

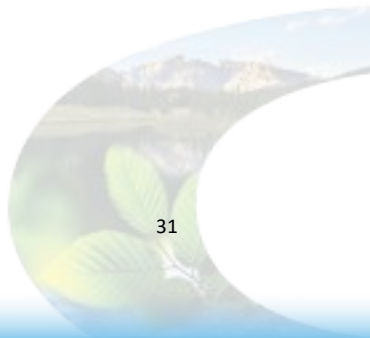

Nozzle Stowage

Drop-In

The “drop-in” type is purely for platform stowages. The interlocking mechanism is typically connected to an electrical interlock switch (a pneumatic interlock valve could also be used).

Ordering Information

Item No	Part No	Description
1	8568	Plunger Interlock Switch
2	8850	Proximity Interlock Switch
3	4600-02-03	Drop-In Handle
4	4600-00-02	Drop-In Nozzle Stowage

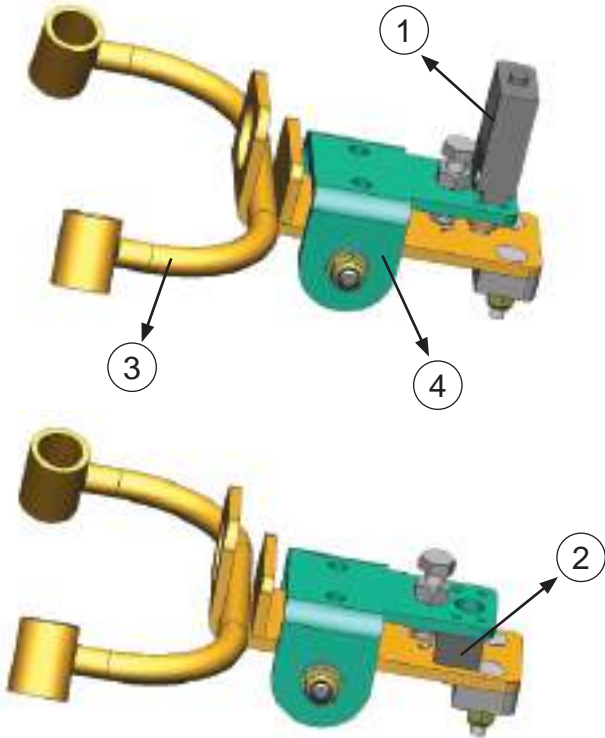



Bottom Load Accessories

OPW EUROLINE SERIES INTERNAL VALVE

CIVACON's EURO100-Line Bottom Valves are designed for increased safety, durability and service performance. The EURO100-Line high flow bottom valves are available as Compact 100-1 series, Super Compact 100-2 series, 4" TTMA or TW 100-3 series and T-shape 100-4 series.

Features & Benefits

- All EURO100-Line Bottom Valves in accordance with EN13308 (Non Pressure Balanced), EN13316 (Pressure Balanced), ADR and API RP 1004.
- Available models: Compact, Super Compact, 4" TTMA or TW outlet and T-Shape.
- Pressure balanced or non pressure balanced operation.
- Sequenced or non-sequenced operation.
- 4" or DN100 connection.
- Lightweight pressure die-cast for improved strength and reduced weight.
- Hard anodized and stainless steel internals.
- Stainless steel filter/strainer.
- Shear Groove to prevent spillage in case of an accident.
- Superior flow rate:
 - up to 2.500 litres/minute.
 - no moving parts in the flow path.
- Viton GLFT seals.
- Valve service inside of the compartment.
- Manually openable in case of emergency.



EURO100-1 Series



Technical Information

Nominal Size	4" or DN100
Working Pressure	5 bar (500 kPa)
Operating Pressure	4 bar
Maximum Flow Rate	2,500 Litre/min
Seals	Vton GFLT
Working Temperature	-20 °C to 70 °C other temps on request
Weight	EURO100-1: 4.6 kg. EURO100-2 : 5.5 kg EURO100-3 : 4.7 kg EURO100-4 : 5.8 kg

OPW EUROLINE SERIES INTERNAL VALVE

Ordering Information

Compact Model: EURO100-1 series

EURO100-1-AL40: 4" non-pressure balanced, non sequenced.
 EURO100-1S-AL40: 4" non-pressure balanced, sequenced.
 EURO100-1B-AL40: 4" pressure balanced, non sequenced.
 EURO100-1BS-AL40: 4" pressure balanced, sequenced.

Super Compact Model: EURO100-2 series

EURO100-2-AL40: 4" non-pressure balanced, non sequenced.
 EURO100-2S-AL40: 4" non-pressure balanced, sequenced.
 EURO100-2B-AL40: 4" pressure balanced, non sequenced.
 EURO100-2BS-AL40: 4" pressure balanced, sequenced.

4" TTMA Outlet Model: EURO100-3 series

EURO100-3-AL40 4" non-pressure balanced, non sequenced.
 EURO100-3S-AL40 4" non-pressure balanced, sequenced.
 EURO100-3B-AL40 4" pressure balanced, non sequenced.
 EURO100-3BS-AL40 4" pressure balanced, sequenced.

4" T-Shape Model: EURO100-4 series

EURO100-4-AL40 4" non-pressure balanced, non sequenced.
 EURO100-4S-AL40 4" non-pressure balanced, sequenced.
 EURO100-4B-AL40 4" pressure balanced, non sequenced.
 EURO100-4BS-AL40 4" pressure balanced, sequenced.

Related Products

SF-100-ST40: Steel sump flange.
10-02-43: Aluminium sump flange.
10-01-74/EU: Aluminium square outlet flange.
10-01-84: Gasket for square outlet flange.



EiURO100-1 Series



EiURO100-2 Series



EiURO100-3 Series



EiURO100-4 Series

OPW EUROLINE SERIES INTERNAL VALVE

Product Specifications

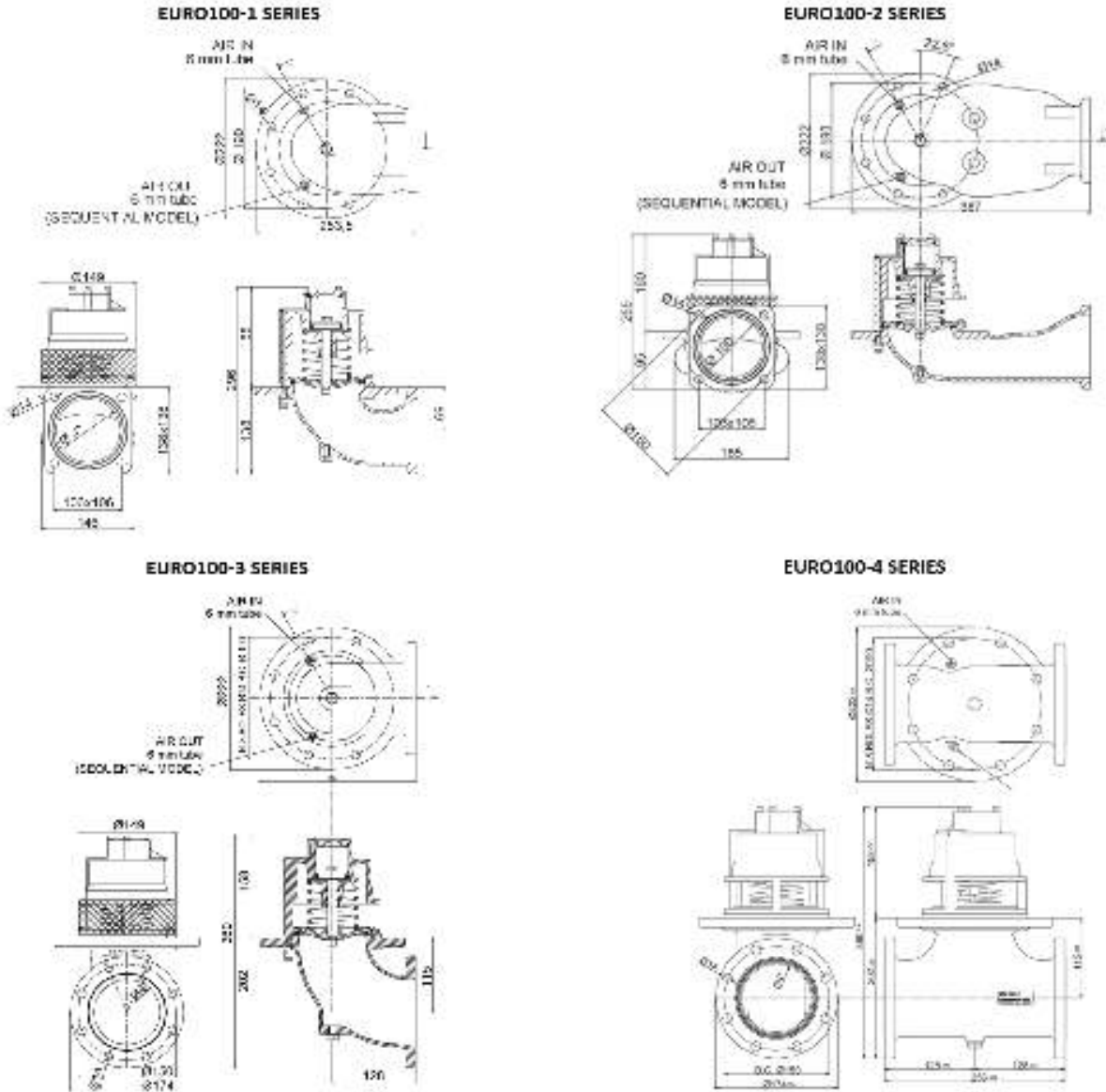

Spare Parts

Repair kit

EURO100RK: Seal kit for EURO100-series Bottom Valve.

Contents EURO100RK Repair kit

- 89-60-75/V: O-ring (Viton).
- 26-60-27: Gasket (Viton).
- 26-60-26: O-ring (Viton).
- 82-30-53: Gasket (Viton).
- 89-60-76/V: O-ring (Viton).
- 92-60-70: O-ring (Viton).

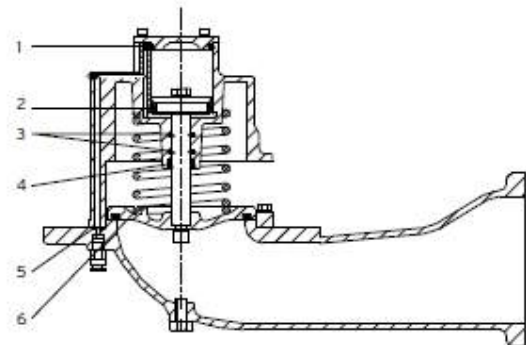

Normec Internal Footvalve

4" foot valve with pneumatic control, pressure balanced design. The foot valve is made so that the shutter position can be checked by the position of a control stem. The shutter can be manually opened by means of a special key, in any case of failure of the air supply (80.40.60).

Technical Specifications

- Flow Rate: Up to 2500 l/min
- Working Pressure: 1000kPa
- Min Operating Air Pressure: 400kPa
- Max Operating Air Pressure: 900kPa
- Air Fittings: 1/8" BSP
- Materials: Aluminium body and valve piston mechanism
 Stainless steel shaft
 Viton seals

Ordering Information

Part No	Description
NOR-904120	Pressure Balanced Internal Footvalve
300605.6	Aluminium Tank Flange to suit
300140.1	Viton Gasket to suit flange



Normec Internal Footvalve

Ordering Information

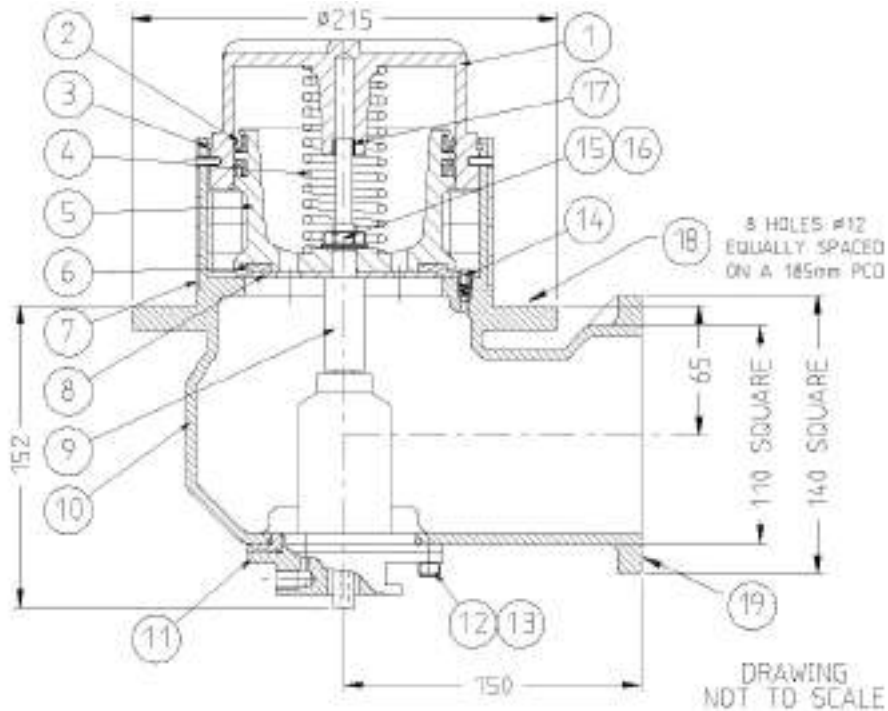

NOR-904120 (Parts List)

Item No	Part No	Description	Qty	Material
1	80.42.73	Compensating Bell	1	Aluminium
2	034.024	U-Seal	2	Viton
3	80.40.04	Spring Clip Internal	1	St Steel
4	90.41.26	Spring	1	N/P M/S
5	80.42.74	Poppet	1	Aluminium
6	80.42.75	Poppet Seal	1	Viton
7	90.41.23	Filtrating Gauze	1	Z/P M/S
8	90.41.24	Seal Retaining Washer	1	Z/P M/S
9	90.41.22	Poppet Spindle	1	St Steel
10	90.41.21	Valve Body	1	Aluminium
11	90.40.50	Piston	1	Aluminium
12	003.039	Capscrew	4	Z/P M/S
13	024.005	Washer Shakeproof	4	Z/P M/S
14	80.43.10	Equalising Pressure Valve	1	Z/P M/S
15	015.063	Nut	1	Z/P M/S
16	027.108	Washer	1	Z/P M/S
17	049.016	Bush	1	
18	300140.1	Gasket	1	Viton
19	300138.2	Square Gasket	1	Viton



Hydrants

A New Generation in Hydrant Pit Technologies

When you buy Liquip products, you're buying a trusted heritage of solutions from the company that's been quietly setting industry standards for over four decades, in Australia and beyond. Our comprehensive line of hydrant pits provide superior operation and easy access for maintenance while meeting the latest EN standard. Liquip can also make double walled steel pits on request.

Our Hydrant pit designs have been proven at airport installations in countries all over the world including: Australia, New Zealand, Singapore and Brazil.

We have taken these trusted designs to the next level and developed an access cover which meets the stringent F900 requirements as part of the EN standard. Even with stricter requirements, Liquip's ingenuity has resolved related manual handling challenges, by allowing covers to be maneuvered easily by one person and with one hand. This is thanks to an easy to use, purpose built tool.

Features Include:

- ✓ **Water Tight Sealing**
Specially designed one-piece construction
- ✓ **Steel or Polyflex Body**
Polyflex: Lightweight option to suit installation restrictions
Steel: Heavy-duty and durable
- ✓ **EN Rated or Lightweight Access Cover Options**
EN F900: 21.5 kg
Lightweight: 15.5 kg
- ✓ **Slip Resistant and Ergonomic Covers**
Keeping ground staff safe
Standard *JET-A1* product ID. Other options: *AVGAS, FH, SV*
- ✓ **Easy One-Hand Operation of Covers**
Less than 25 kg force required thanks to a purpose built tool.
- ✓ **Two Sizes Available**
450mm (18") with inner lid (aperture = 16")
600mm (24") with inner and outer lid (aperture = 23.5")
- ✓ **Latching and Lifting Options**
EN Rated Cover - lifting tool, no lock
Lightweight Cover - locking mechanism with lifting handle
- ✓ **Tethering Options**
Tethering options to meet latest EN and JIG standards
- ✓ **Inlet Flange Kit Options**
Pits can be supplied with steel or stainless steel flanges
- ✓ **100 Litre Capacity (24" PolyFlex Pit)**
Up to 45 Litres before any potential leak point (bellow/riser).



Steel Hydrant Pit & EN approved Cover

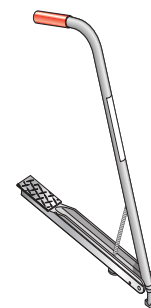

Purpose Built Lifting Tool



Inlet flange kit

Leading the Way in Hydrant Pit Technologies

Steel Body

EN Approved cover option shown



Removable outer lid for increased access

Easy removal with lifting tool

Steel Body

Polyflex Body

Lightweight cover option with lifting handle



PolyFlex Body

A True Breakthrough in Aviation Technology

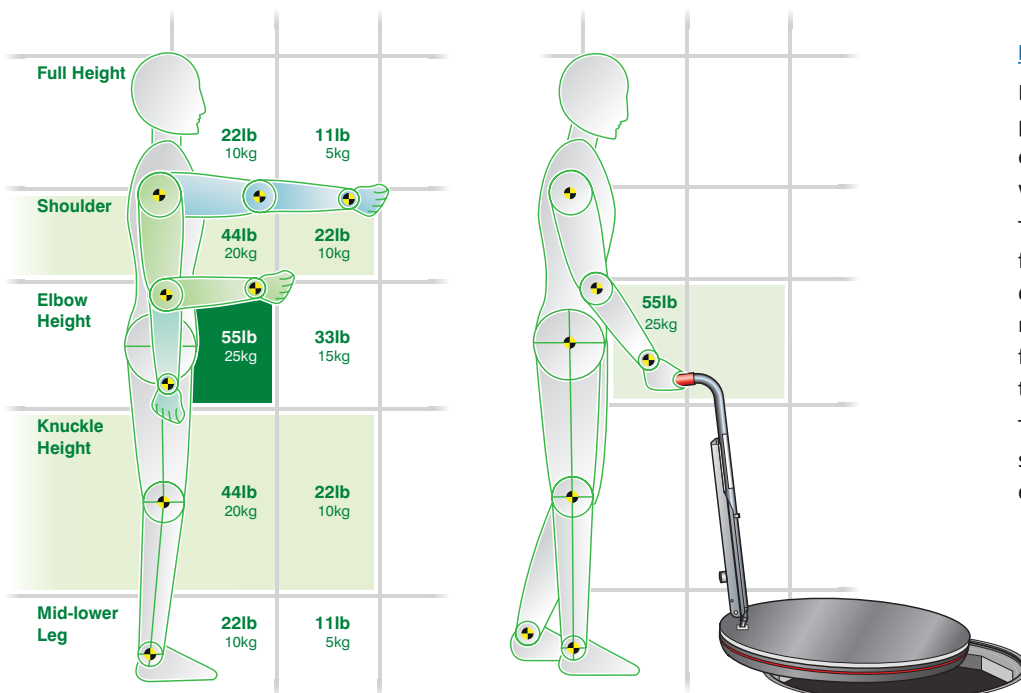

Easy and Safe Lifting

Liquip's new generation of hydrant pit covers have been proven to be ergonomically safe for men and women to remove and replace.

The design incorporates a lifting point for our specially designed FL7 lifting device. These allow operators to remove the cover without trapping fingers or bending over, maximising the safety of the lifting technique.

The charts on the left show that the safest place to lift or pull a load is close to the body at waist height.

Health & Safety recommendations for load moving capabilities (male) in relation to weight and position.

Hydrant Pit - Polyflex

The future of hydrant pit technology

Liquip Polyflex Hydrant Pit is one quarter the weight of conventional pits, and provides a non-conductive, seamless, advanced-sealing pit. It comes complete with a light-weight lid, offers easy maintenance and improved product retention in case of spills or drips.

This assembly provides an environmentally sealed container for aircraft runways where fuelling and inspection access is required. Generally designed for most industry pit refuelling valves & high/low point drains. The covers and rims have been designed to exceed the extremely high loads & standards set down by the aviation industry.

The durable pit body is a high-tech polyethylene one-piece construction with cast aluminium rim fitted into the body to provide a liquid-tight bond. The Polyflex pit holds up to 100 litres of product with the valve in place and as the bellows is moulded to the body, there are no separate seals.

The body is electrically non-conductive, consumes no cathodic protection power and the sloped bottom ensures fluid build-up in the pit is drained to one side so it is immediately noticeable and easier to clean.



Hydrant Pit - Polyflex

Technical Specifications

Variants:	HPA100, HPA150, HPA200 and HPA250
Pit Body:	High density polyethylene, non-conducting UV stabilised for outdoor storage Working temperature range: - 40 degrees C to 200 degrees C Yield 18Mpa S.G. 0.94 Elongation 450% Flex modules 690Mpa
Pit Rim & Outer Lid:	Aluminium AA601 heat treated and aged T6
Weld Neck:	100mm or 150mm ANSI 150 with fully sealed blind drilled and tapped stud holes, machine finish outside diameter and fastening point for bonding strap. The bonding strap runs from the pipe to the pit rim and is stainless steel.
Integral Bellows:	The integral moulded bellows provides seamless flexibility to accommodate the riser pipe. The 24" pit retains 45 litres before the liquid level reaches the top of the bellows. The bellows has an extended top, allowing variable installation height and surplus can be trimmed back. Entry point is designed for 100mm ANSI 150 bolt pattern weld neck flange with thick flange for improved sealing.
Lightweight Lid:	The HLA100 is the lightest pit lid on the market today which can still withstand the high forces and weights exerted by aircraft as set out in some specifications. It has an automatic self latching feature with single latch mechanism and an anti-slip top. It fits both the 18" and 24" pit (the 24" pit has an "outer lid"). The outer lid on 24" pits can also easily be removed when a larger access area is required for maintenance purposes.
Weight Comparison:	Conventional Steel Pit with Lid, 18" ± 115 kgs Conventional Steel Pit with Lid, 24" ± 158 kgs Conventional Aluminium Lid ± 25 kgs Liquip Lightweight Aluminium Lid, HLA100 ± 13 kgs Total Weight of Liquip HPA200 (24" Pit, 4" Bellows) ± 75.5 kgs Total Weight of Liquip HPA250 (24" Pit, 6" Bellows) ± 85.0 kgs Total Weight of Liquip HPA100 (18" Pit, 4" Bellows) ± 32 kgs Total Weight of Liquip HPA150 (18" Pit, 6" Bellows) ± 32 kgs

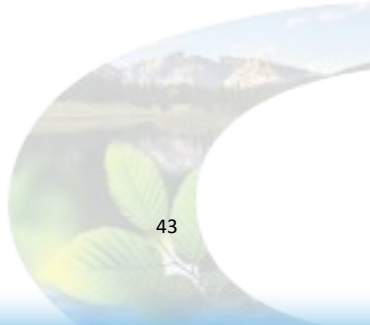

Hydrant Pit - HPA100

Ordering Information

A 570mm diameter light weight Hydrant pit assembly with integral bellows to accept a special 100 NB flange & 100NB pit valves. The assembly comes complete with both inner and outer covers.

Item No	Part No	Description
1	HLC100-1	Body Pit Hydrant 450
2	HLC100-4	Rim Pit Hydrant 460 Aluminium
4	HLA100	Cover Hydrant 450mm Aluminium
6	HLC200-12	Flange Kit 100mm 150lb
7	HLC100-10	Clamp Ring for Hydrant to 100mm Bellows to Pit Flange
14	HLC200-11	Bonding Kit (Supplied separately)

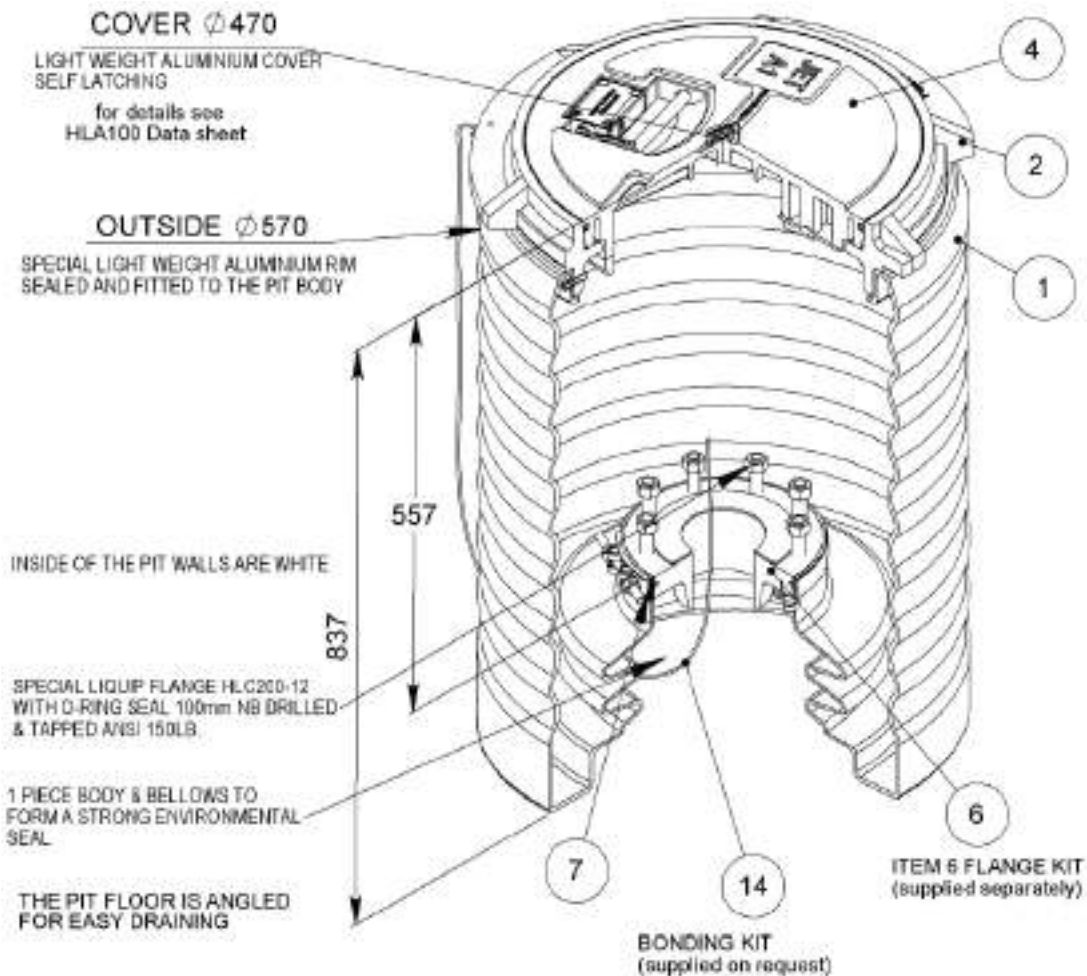

Hydrant Pit - HPA150

Ordering Information

A 570mm diameter light weight Hydrant pit assembly with integral bellows to accept a special 150 NB flange, 150NB & 100NB pit valves. The assembly comes complete with both inner and outer covers.

Item No	Part No	Description
1	HLC100-1	Body Pit Hydrant 450
2	HLC100-4	Rim Pit Hydrant 460 Aluminium
4	HLA100	Cover Hydrant 450mm Aluminium
11	HLC150-5	Bellows Hydrant Pits All
12	HLC250-12	Kit Flange for 150mm Bellows
13	HLC150-10	Clamp for 150mm Bellows HLC150
14	HLC200-11	Bonding Kit (Supplied separately)

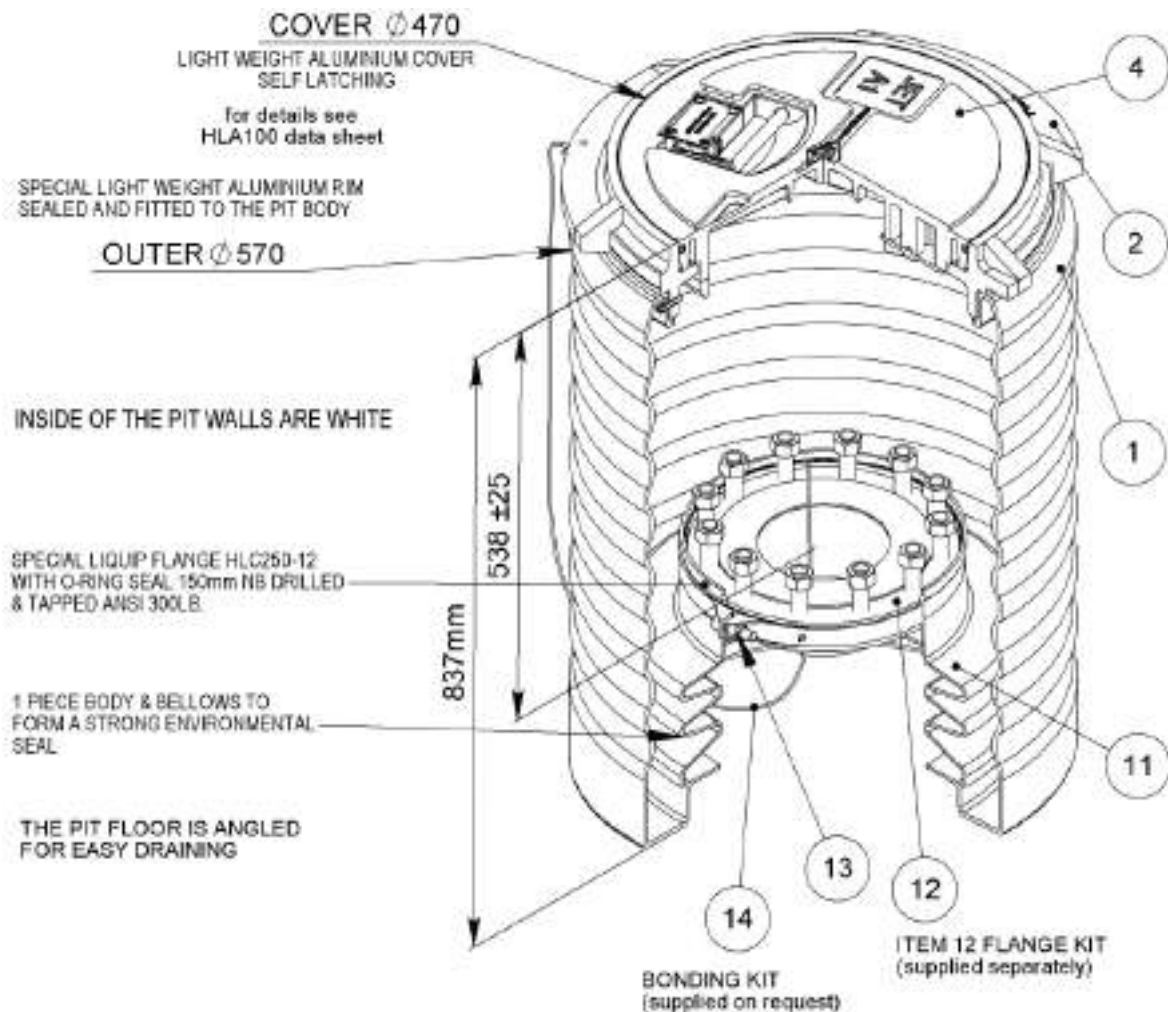

Hydrant Pit - HPA200

Ordering Information

A 700mm diameter lightweight Hydrant pit assembly with integral bellows to accept a special 100 NB flange & 100NB pit valves only. The assembly comes complete with both inner and outer covers.

Item No	Part No	Description
1	HLC200-2	Body Hydrant Pit 600mm Details
2	HLC200-3	Outer Lid Assembly 450 x 600mm
3	HLC200-12	Flange Kit 100mm 150lb
7	HLC200-10	Seal for Outer Lid Hydrant Pit
8	HLC100-10	Clamp Ring for Hydrant to 100mm Bellows to Pit Flange
9	HLA100	Cover Hydrant 450mm Aluminium
10	HLC200-11	Bonding Kit (Supplied separately)

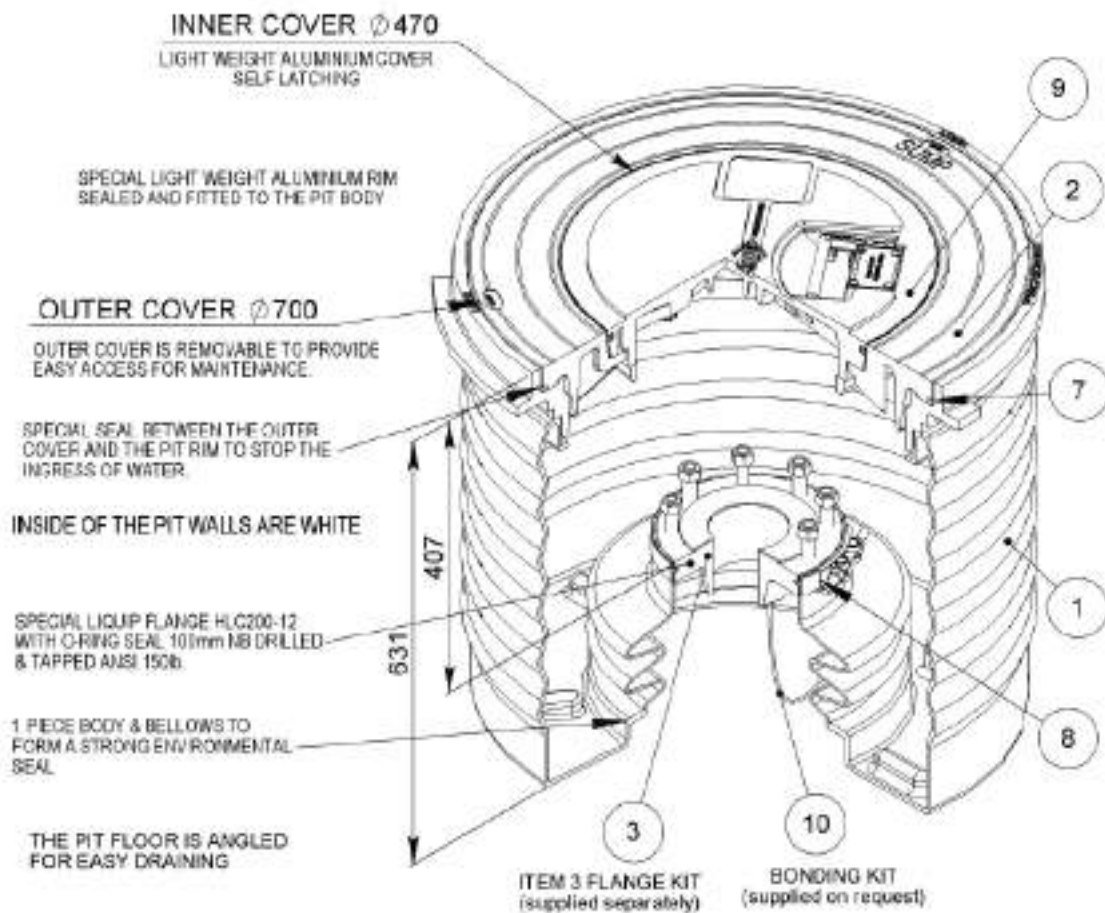

Hydrant Pit - HPA250

Ordering Information

A 700mm diameter light weight Hydrant pit assembly with integral bellows to accept a special 150 NB flange, 150NB & 100NB pit valves. The assembly comes complete with both inner and outer covers.

Item No	Part No	Description
1	HLC250	Body Assembly 600mm
2	HLC250-12	Kit Flange for 150mm Bellows
3	HLC200-3	Outer Lid Assembly 450 x 600mm
4	HLC150-10	Clamp for 150mm Bellows HLC150
5	HLC200-10	Seal for Outer Lid Hydrant Pit
9	HLA100	Cover Hydrant 450mm Aluminium
10	HLC200-11	Bonding Kit (Supplied separately)

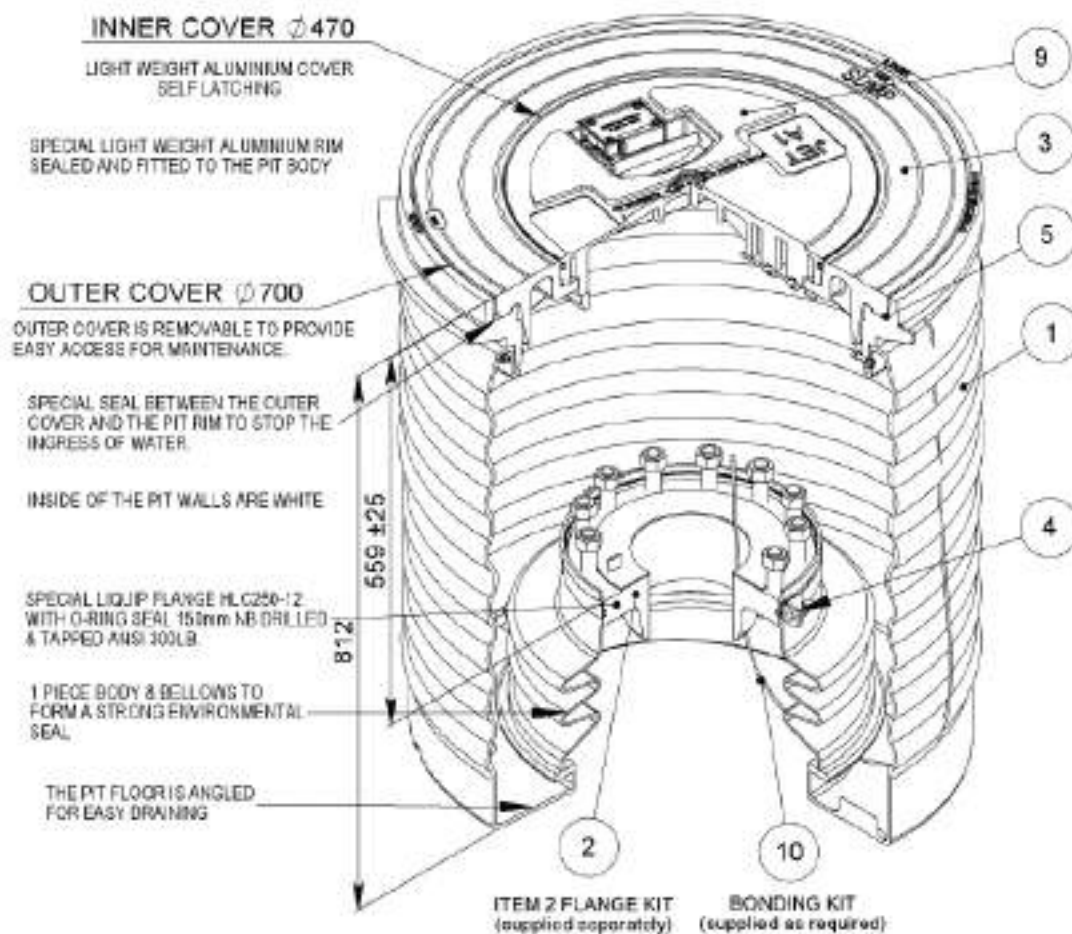

Hydrant Pit Valves

The Carter Model 60554 Hydrant Pit Valve is a family of valves that includes lanyard, air or dual air/lanyard operated pilot valves, with the latter available with a defueling option. The hydrant pit valve consists of three basic parts, lower valve assembly, upper valve assembly (or API outlet adapter) and the pilot valve. The lower valve assembly contains an isolation valve which will allow the removal and servicing of the upper valve assembly and the pilot valve assembly while the pit valve is under pressure.

The Model 60554 hydrant pit valve is API1584 3rd edition compliant and is designed to minimize the propagation of surge pressure shocks into the upstream piping system during closure of the valve.

Features

- Two-piece upper half standard, replaceable API outlet adapter of stainless steel per API Bulletin 1584. Ductile iron and all stainless uppers optional.
- Standard inlet flange mates with 4-inch 150 lb. ANSI flange.
- Optional inlet flange mates with 6-inch, 300 lb. ANSI flange making valve conform to the IP Standard.
- Closing time is 2-5 seconds.
- Opening time is 5 to 10 seconds.
- Servicing valve standard to provide means to remove the upper valve assembly and pilot valve assembly with the unit under pressure.
- 10 or 20-mesh screen options available.
- All seals are field replaceable.
- Large pressure equalizing valve in the outlet is standard.
- Working pressure – 300psi
- Stone guard optional with 6-inch inlet flange option.
- Ductile iron epoxy coated for corrosion protection
- Main piston well guided to minimise piston seal wear.



Hydrant Pit Valves

Pilot Options

- Model 60554D — Lanyard operated pilot valve for manual on/off control. Valve allows flow in the fuelling direction only.
- Model 60554E — Air operated pilot valve for deadman control. Valve allows flow in the fuelling direction only.
- Model 60554F — Dual air and lanyard operated pilot valve for deadman control and manual on/off control for use in small pits only (12 or 13 inch diameter). Unidirectional only, unless combined with option J.
- Model 60554J — Air operated pilot valve for deadman control with defuel control to allow flow of fuel in either fuelling or defueling direction
- Model 60554-3D — Same as Model 60554D except material of outer housing is ductile iron per ASTM A395 (special order only). The upper and lower valve assemblies are fastened together with 15 metric threaded screws instead of the normal 8-UNF threaded screws (replaced Model 60554-2D). Two piece upper half not available on this unit.

- Model 60554X — Remove the pilots from the Hydrant Valve and replacing it with a sealed male disconnect fitting. As a result you only need to have one pilot for each hydrant servicer rather than one for each hydrant valve, reducing cost. The remote pilot is also sealed and thereby eliminates issues related to the inward breathing pistons in the conventional pilots which can inhale contaminants resulting in internal corrosion and increased maintenance. Fuel leakage into the hydrant servicer’s pneumatic system is also not possible with this design. The remote pilots are compatible with air or fuel command systems.



- Model 60554Y — As per X pilot but with Pneumatic operated “fork” mechanism to eject the remote pilot, effectively making it a dual pilot (part number 47834)



- Model 60554Z — New Dual Pilot (for Pit Boxes 18” in diameter and larger):
Additionally, for those users who require the dual pilot to be permanently attached to the hydrant valve, Eaton now offers a new Option “Z” pilot. This pilot adopts the sealed piston technology from our remote pilots into a compact lanyard mechanism that eliminates issues related to the inward breathing pistons in the conventional pilots. Fuel leakage into the hydrant servicer’s pneumatic system is also not possible with this design.



Existing hydrant valves can easily be converted to any of the remote pilot options. They eliminate all of the common maintenance issues related to contaminated fluids entering the pilot piston area of existing “E”, “F”, or “U” pilots and also eliminated the possibility of fuel entering the pneumatic systems on the hydrant servicer.

Hydrant Pit Valves

New Remote Pilots:

These remote pilots stay attached to the hydrant servicer via the command hose and they can be energized with either air or fuel:

Part number 64230 Simple Disconnect (requires manual lifting of the collar to engage and to disengage)

– OR –

Part number 64280 Push-On Disconnect can be pushed on, but collar must be raised to disengage, or will disengage automatically when pulling the lanyard on the Option “Y”, noted above.

Optional extension handle available on both remote pilots.



Ordering Information

Option letters may be combined with the basic units, except as noted, to customize the valve to fit specific installation requirements. Note basic models referenced on page 2, “Model Descriptions” section.

Option	Description	Option	Description
A	Adds 10-mesh screen between upper and lower halves of the unit (81557-10)	M	Adds dry break (with bleed) to option E, F, J or U air connection (not available on option X)
B	Adds 20-mesh screen between upper and lower halves of the unit (81557-20)	N	Adds adapter kit for installing unit into 12 or 13 inch Avery Hardoll pits with 3 inch ANSI mounting flanges. Can not be used with options G, H, K or L.
C	Adds six-position product selection (44290)	P	Adds 4 inch spool piece to convert inlet flange to mate with 6 inch 300-lb ASA raised face flange (47199). Resultant valve height is 16 inches (special order on 60554-2D & 3D).
G	Adds spool piece to convert inlet flange to mate with 6 inch 300-lb. ANSI flange to meet IP standard (44364) (special order on 60554-2D & 3D)	Q	Changes upper half housing (adapter) to one piece ductile iron (special order - not available on Model 60554-3D)
H	Adds 4-mesh stone guard to inlet. Available only with option G above (43578)	R	Changes upper half housing (adapter) to two-piece ductile iron/stainless steel (not available on Model 60554-3D — special order)
K	Adds adapter kit to D, E or F options only, to mate Avery Hardoll 12 inch pits. Can not be used with option U.	S	Changes upper half housing (adapter) to 316 stainless steel (43214-4) (special order)
L	Adds adapter kit to D, E or F options only, to mate Avery Hardoll 13 inch pits. Can not be used with option U.	T	Adds fusible plug to air port to either E, F, J or U options only (not available on option X)

Example: 60554BDGH — IP standard unit with 6 inch inlet, manually operated pilot valve, stone guard and 20-mesh screen

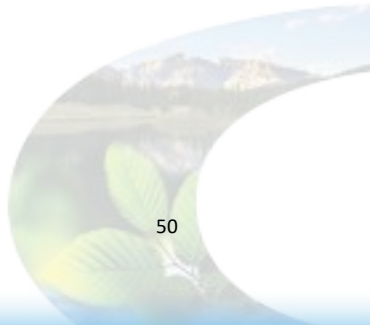

Hydrant Lid Tether

Liquip Hydrant Pit tethering systems are available for new and existing pits. Installation is simple and ensures compliance with JIG Bulletin No.10.

Ordering Information

Part No	Description
PRS100	Tether pit retaining system to suit Liquip Hydrant Pits HPA2xx series
PRS200	Tether pit retaining system to suit Liquip Hydrant Pits HPA1xx series

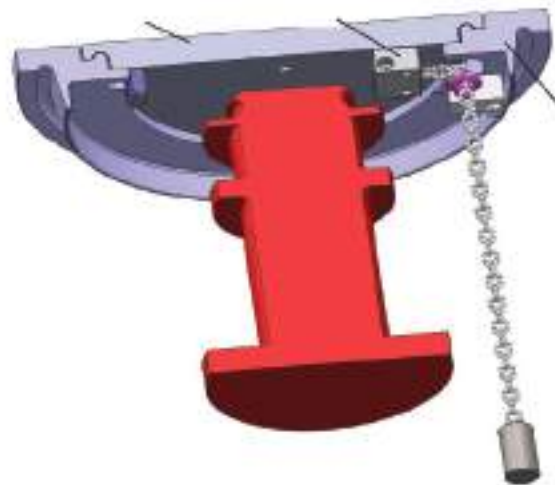
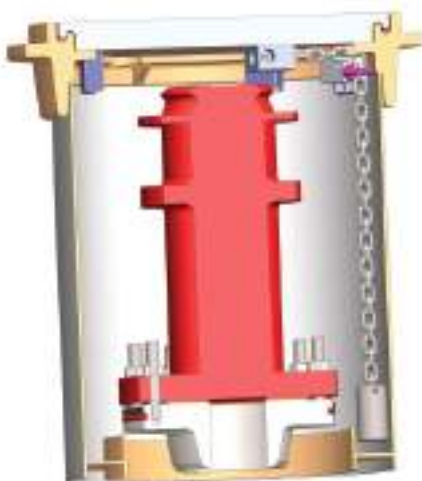



Meters & Pumps

Electronic Meter Register - DFV Series

The DFV100 series is the latest advancement in Liquip’s range of electronics, featuring as a stand alone register or Diptronic CPU.

The DFV101 is a state of the art electronic meter register and level gauging monitor in one compact housing.

The DFV101 allows for increased operational efficiency through a lightweight design and by combining two units into one, users will be able to achieve the benefits of both units by ordering a single unit.

The DFV101 is approved for Zone 1 (IECEX) truck mounted or fixed site product transfer applications..



Key Features

Common to all potted DFV units

- Weights & Measures Approved: NMO UK, NMI-Aust & NZ, Europe - MID & NTEP - USA (EU & USA = Register function only).
- Durable Aluminium housing with hinged door to allow easy access to internal connections.
- Large display to easily view multiple information simultaneously.
- RS232 and CAN communication.
- Intuitive set up and programming.
- Electronic calibration.
- Non-linearity correction.
- Non volatile memory for storing set parameters.
- Operates on 12 or 24 volt installations.
- Backlit display for easy viewing in low light.
- Piezoelectric buttons for reliability.
- Connection to a ticket printer or a third party fuel management system.
- Can be connected to a large digit display
- Micro SD card for easy software upgrades.

Register

- Preset functionality / batch control.
- Solenoid outputs are voltage free and can perform a 2 stage ramp up and ramp down of the fluid flow.
- No flow timer.
- One calibration point with Weights & Measures sealable captive fastener.
- Compatible with most flow meters on the market.
- Pulse output can be programed as optional additional fourth relay.
- Functionally backwards compatible with Liquip EMH registers.
- Flowrate displayed on main screen along with volume during delivery.
- Future expansion and modularity available.

Diptronic

- Automatic level gauging updated in real time keeps users off the top of the tank.
- Same menu system as DIP200 for ease of operation with operators already familiar with Liquip Diptronic.
- CAN output for rapid communication with external device.
- Can read up to 6 probes/compartments.
- Can be used to provide a sealed parcel solution.
- DFV103 comes with built in power filter negating the need for external power filter.
- Can be connected to slave unit to read an additional 6 probes/compartments.
- Volume shown in 1L increments.
- ±1mm accuracy with no moving parts for minimal maintenance.
- Compatible with E 705 Diptronic probes (pots).
- Enables temperature compensated deliveries.
- Enables split deliveries to maximise fleet efficiency.

Safety Approvals (All units)

IECEX

- Safety Approved for use in Zone 1 (IECEX). IECEx TSA 14.0021X Ex e ib mb [ia] IIA T4 Gb IP66 (Ta = -20°C to +60°C)

ATEX

- Safety Approved for use in Zone 1 (ATEX) DEMKO 14 ATEX 1407X Ex e ib mb [ia Ga] IIA T4 Gb IP66 (Ta= -20°C to +60°C) 0518 II 2 (1) G

UL

- UL Safety Approved - USA & Canada for use in Class 1 Zone 1. Cl. I, Zn1, AEx e ib mb [ia Ga] IIA T4 Gb EX e ib m [ia Ga], IIA T4 Gb Ta= -20°C to +60°C Um = 32V

E477774

Associated Equipment

- ERP200 - Remote Pulser
- 4155 - Temperature Probe
- DFV100 - DFV Register
- DFV103 - DFV Diptronic CPU
- DIP130 - Diptronic Stick
- DIP150 - Diptronic Stick - Low Profile
- Expansion Modules - Contact Liquip
- Cold climate register - Contact Liquip

Issue 10 - Aviation Components Catalogue

www.liquip.com

Electronic Meter Register - DFV Series

Technical Information

Size	Approx, 250 x 200 x 140mm
Displays	1 line x 14 characters 14 mm high and 4 lines x 24 characters 8 mm high
Power Input	9 to 32Vdc (safety approved) or 9 to 45V (operational) @ 250mA polarity protected. In-line fuse (rated 3A, antisurge) is strongly recommended
Operating Temperature	-20°C to +60°C (safety approved)
Temperature Correction	-40 to +60°C for all petroleum products Extended ranges available according to local regulations
Temperature Probe	Pt100 class A, 3 wires, Liquip P/N 4155
Ingress Protection	IP66
Product Density	0.653 - 1.075kg/L (petroleum products) - For others contact Liquip
Weight	Approx. 6kg
Communication	Two RS232C ports to be used to communicate with a PC or other serial device such as a modem or printer. One CAN port. Compatible with Epson CTM-290 or TM-295, Blaster Printer.
Touch PC	Commands that can be interrogated include resetting the meter and requesting the current delivery quantity. See software section for detail.
Pulse Input	Will accept 3-channel pulses of 60° phase shifted, from ERP200 pulser, dual (quadrature) or single pulse (reed or open-collector) from third-party pulsers. Third party pulsers may not be NMI approved
Pulse Output	Open drain, active-low output, signal calibrated to 10 pulses/litre, where the pulse frequency can be set up to either 400Hz or 2kHz max. (with fixed pulse duration 1.25 ms or 0.25 ms respectively).
External Reset	This is an input/output signal.
Relay Outputs	Up to 4 Relay Outputs. Current sink, 3A max. Solenoid to be connected between this output and the positive of the power supply. Additional in-line fuse (3A, antisurge) is strongly recommended.
Program Memory	microSD card

Mounting Instructions

The DFV101 can be either remote mounted or mounted to a meter using an adaptor bracket.

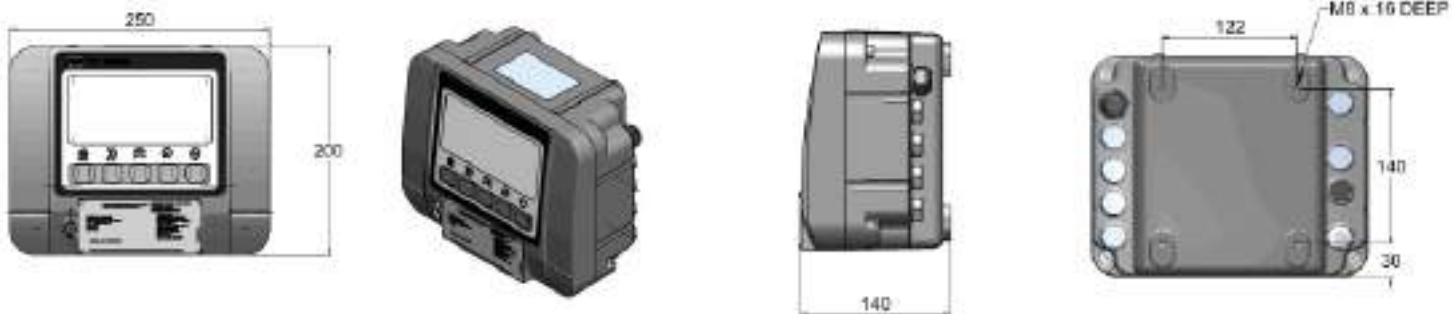

Adaptor Bracket: Front mount to various meters

When direct mounting to a meter is unavoidable

DFV100-23 (Suits the following meters)

- LC - M5, M7, M10, M15, M25, M30, M40, M60
- SAMPI - M5, M7, M15, M30

Adaptor Bracket: Top mount to various meters

DFV100-18 - Top mount bracket to suit meters that use the OE standard 4 bolt register mount.

For mounting to other meters please contact Liquip

Issue 10 - Aviation Components Catalogue

www.liquip.com



Electronic Meter Register - DFV Series

With a range of models available and combining the best in performance, style and functionality, the DFV is the right choice for Register and Diptronic applications.



	DFV100	DFV103	DFV101
Register	✓	✗	✓
Diptronic	✗	✓	✓
Updateable*	✓	✓	✓
Upgradeable**	✓	✓	N/A
Operating Temperature	-20°C to +60°C	-20°C to +60°C	-20°C to +60°C
IP rating	IP66	IP66	IP66

SAFETY APPROVALS

	DFV100	DFV103	DFV101
Suitable for: Zone 2 IEC Ex	✓	✓	✓
Zone 1 IEC Ex	✓	✓	✓
Zone 1 ATEX	✓	✓	✓
Class 1 Zone 1 ULus, cUL	✓	✓	✓

METROLOGICAL APPROVALS

	DFV100	DFV103	DFV101
NMO UK	✓	✓	✓
AUST W&M	✓	✓	✓
NZ W&M	✓	✓	✓
MID - OIML (EU)	✓	✗	✓+
NTEP	✓	✗	✓+
Measurement Canada	PENDING	PENDING	PENDING

* Updateable: Free software updates are available as issued by Liquip.

** Upgradeable: Chargeable upgrades are available to convert a DFV100 or DFV103 to a DFV101.

+ Approval is only applicable for Register function.



Pulser - ERP200

The ERP200 Series Electronic Remote Pulser is designed to convert signals from a rotating shaft into an electrical signal. The apparatus comprises a printed circuit board (PCB), a metallic mounting bracket and a plastic slotted disk (shaft) all housed in a plastic enclosure. Access to the internal block is via a plastic lid fitted with a rubber O-Ring and mounted with screws.

There are several situations where a remote pulser may be preferred or even required:

- (i) When buying a meter capsule only, with no register or drive and no calibration gears. A remote pulser is much cheaper to buy and much less to maintain.
- (ii) When there is no room to have a mechanical or electronic register mounted on the meter. The remote pulser is much smaller than any register.
- (iii) Using a remote pulser also allows the register to be mounted in a better viewing position.

A solid-state pulse transmitter provides accurate readings at high revolutions for remote applications.

A quality sealed plastic housing is able to operate in a broad temperature range with excellent impact and chemical resistance.

The electronic pulse transmitter has three opto sensors each sensor producing 25 Pulses per revolution, thus producing 150 combinations of pulses per revolution. The pulses signals are used by Registers for measuring purpose.

With three opto sensors, the pulse transmitter can detect:

- (i) Flow direction
- (ii) Faulty opto sensors
- (iii) Loss of power.



Pulser - ERP200

Electrical:

When the application of the ERP200 Series is in areas subject to safety requirements such as oil company operations, it is essential that all legislative, industry and company requirements be thoroughly researched and understood. Not only do these vary from country to country but also there are some 'grey' areas with the operation of vehicles in zoned places such as loading gantries.

All ERP200 Series equipment is certified for Zone 0 installation. Installation shall be carried out in accordance with the applicable code of practice by suitably trained personnel.

Following instructions contain details on wiring and how to avoid interference from extraneous sources. In all cases, use the Liquip power filter as that contains power-filtering equipment to ensure a clean, stable power supply to the electronics.

Electronic boards are a hybrid of surface-mount and through-hole components each being selected according to past experience of reliability and mechanical strength.

Safety Certification:

1. IEC Ex

Certificate: IECEx TSA 08.0043X

Marking: Ex ia IIA T4 IP66

Ta = -20°C to +60°C

2. ATEX

Certificate: TRAC09ATEX11220X

Marking:

CE 0518 I I 1 G

Ex ia IIA T4 IP66

Ta = -20°C to +60°C

Conditions of Safe Use:

1. Input Parameters: $U_i = 26.6V$, $I_i = 660mA$, $P_i = 1.2W$, $C_i = 1.14\mu F$, $L_i = 0mH$.
2. Warning: In Zone 0 only: Electrostatic Hazard. Do not rub. Clean with a damp cloth. Do not use solvents.
3. Port entry: Use suitable conduit or cable gland, min IP66.
4. Any length of connecting cable may be supplied subject to satisfying the L and C parameters of the equipment.

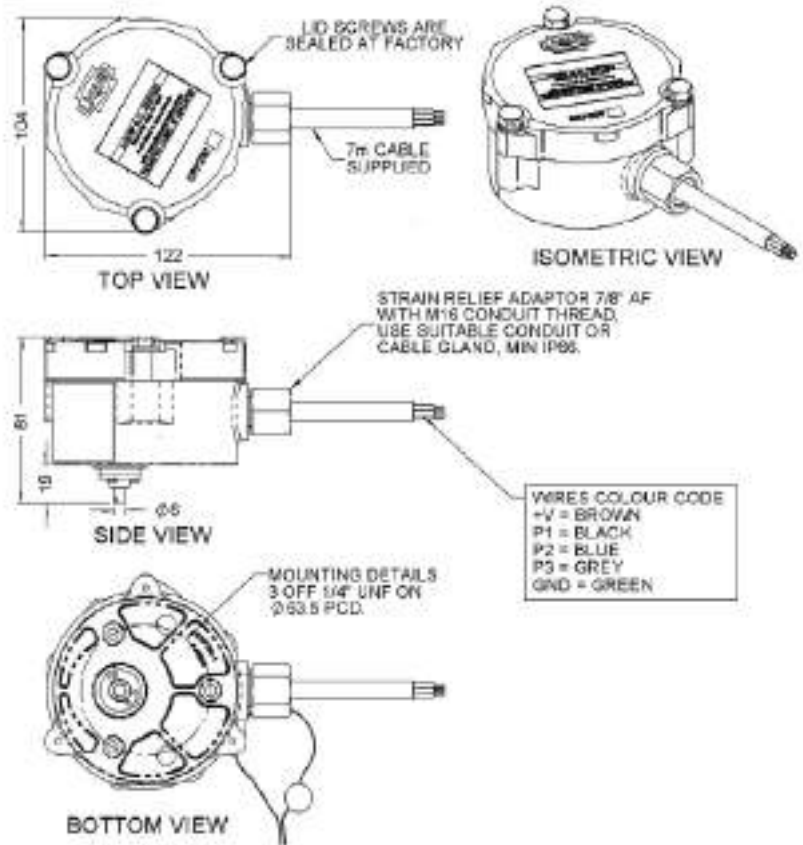

Weights and Measures Approval:

1. AUSTRALIA: NMI S351A, S407



Pulser - ERP200

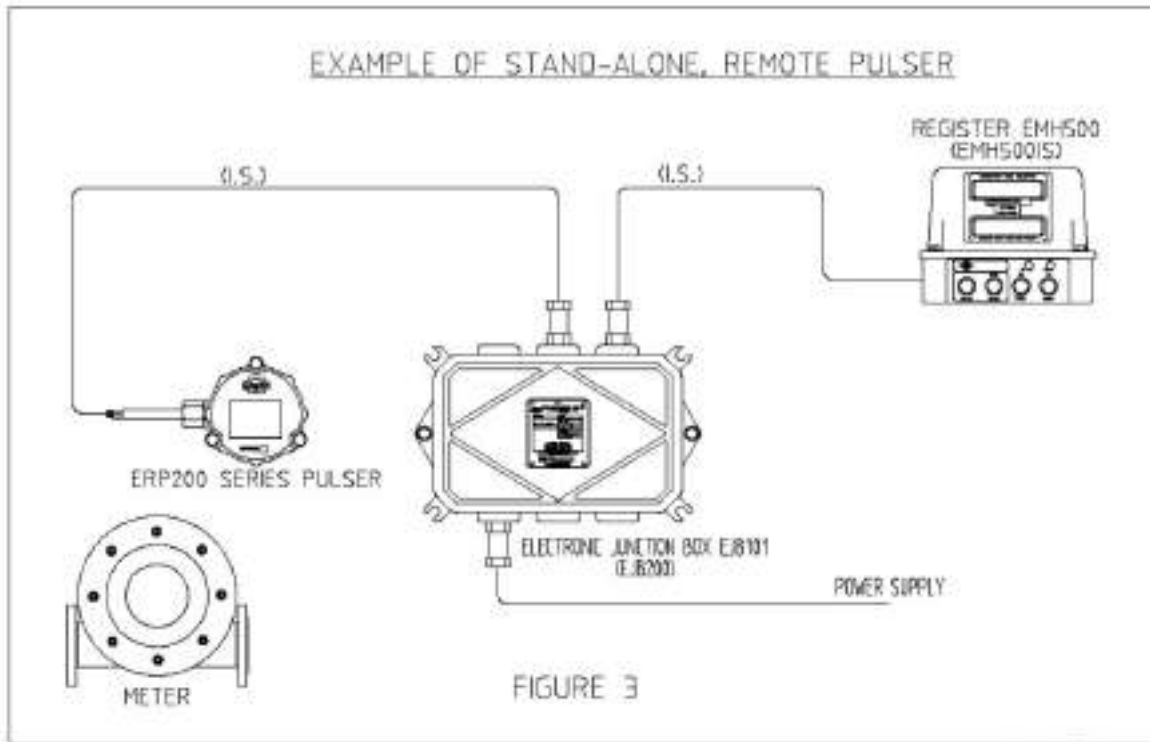

Ordering Information (Kits)

Kits for mounting Remote Pulser (Top Mount)	
Part No	Description
EPM200-3Z	Meter kit for electronic remote pulser to top mount to Neptune meter
EPM200-4Z	Meter kit for electronic remote pulser to top mount to Sampi & Lc meters WITH calibrator
EPM200-7Z	Meter kit for electronic remote pulser to top mount to Lc meters NO calibrator (to suit Lc meter with old style drive)
EPM200-9Z	Meter kit for electronic remote pulser to top mount to Lc meters NO calibrator (to suit Lc meter with hexagon drive)
EPM200-5Z	Meter kit for electronic remote pulser to top mount to SBM meters
EPM200-6Z	Meter kit for electronic remote pulser to top mount to Smith meters

Kits for mounting Remote Pulser (Direct Mount)	
Part No	Description
EPM100-3Z	Meter kit for electronic remote pulser to direct mount to Lc meters
EPM100-4Z	Meter kit for electronic remote pulser to direct mount to SBM meters
EPM100-7Z	Meter kit for electronic remote pulser to direct mount to Sampi meters
EPM100-8Z	Meter kit for electronic remote pulser to direct mount to Avery-Hardoll meters

Junction Box - EJB101

Liquip electronic system requires complete integrity of power supply to guarantee data communication is not corrupted. The EJB101 has been produced to provide the complete power interface.

The cast aluminium housing has a weather-proof seal and is Ex 'e' rated. Five ports are provided - one for the supply from the vehicle battery (9v to 30v), one output to supply power and communication to the register and the remaining ports are for the auxiliary devices (such as communication ports, temperature probe, remote pulser and solenoids). These ports may require approved glands and conduit to comply with regulations. The single electronic board is manufactured to Cenelec standard for the intrinsically safe barrier and also provides circuit protection and power conditioning for surge and ripple protection.

The EJB200 is built for intrinsically safe barriers and also provides circuit protection and power conditioning for protection against ripples and surge.



Sampi Meters

Exceptional Accuracy

The SAMPI positive displacement (PD) meters are ideal for tank truck or depot applications. For metering aviation gasoline and jet fuels the Class 2 meter has a nonferrous construction and SAMPI is approved for use by NSC (Australia) and other major international weights and measures regulatory bodies.

Superior Accuracy at constant flow

With all other conditions being constant, the SAMPI meter does not vary more than 0.05% in repeatability over the entire range.

Accuracy over the widest range of flow

The SAMPI meter has an ideal combination of minimum seal or slippage area with lowest pressure differential across the seal. This results in better accuracy over a wide range of flow than available in other type of commercially produced positive displacement meters.

Accuracy regardless of pressure fluctuations

With the SAMPI meter's unique dual-case design, the bearing surfaces of the meter element are internally and externally subjected to the same system pressure. Therefore, the meter element cannot be stretched or distorted to cause changes in seal area that would adversely affect accuracy.



Sampi Meters

Ordering Information

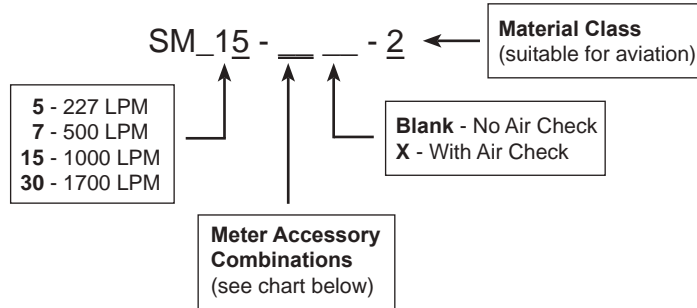

Meter Accessory Combinations

	NO STRAINER NO AIR ELIMINATOR NO VALVE	STRAINER NO AIR ELIMINATOR NO VALVE	STRAINER AIR ELIMINATOR NO VALVE	NO STRAINER NO AIR ELIMINATOR VALVE	STRAINER NO AIR ELIMINATOR VALVE	STRAINER AIR ELIMINATOR VALVE
COUNTER NO PRINTER NO PRE-SET	A 	B 	C 			D
COUNTER PRINTER NO PRE-SET	E 	F 	G 			H
COUNTER NO PRINTER PRE-SET				I 	J 	K
COUNTER PRINTER PRE-SET				L 	M 	N
NO COUNTER NO PRINTER NO PRE-SET	P 	R 	S 			T

Sampi Meters - SM 5

Ordering Information

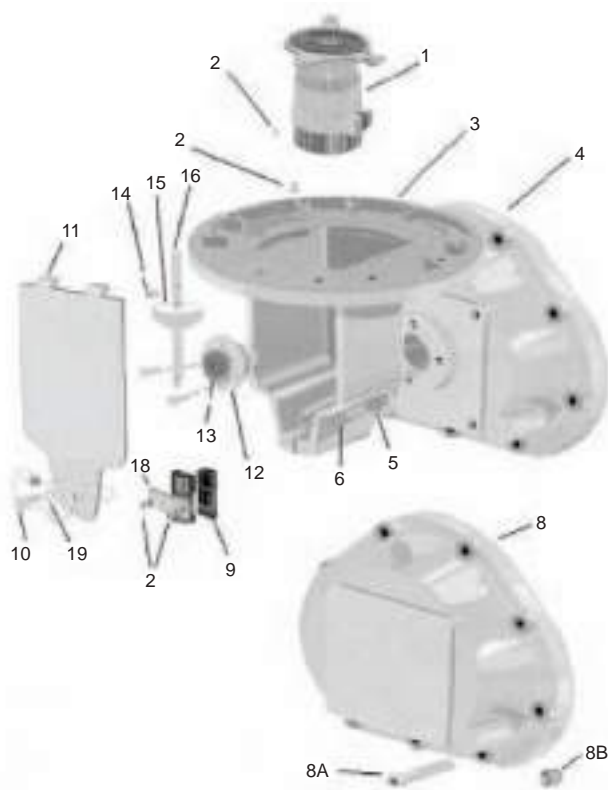

* Contact Liquip for confirmation of spare parts

Cover Assembly			
Item No	Part No (Class 2)	Description	Qty
1	2030040101	Adjuster Assembly	1
2	N320005010A	Screw 5 Pgx10 8,8 Z Iso 1217	4
3	I0000-25170	Bracket Counter Adapter	1
4	I0123-501148	Cover Front	1
5	*I0705-06743	Flat Washer (.265 ID)	4
6	*I0673-09084	Screw, Counter Bracket (1/4-20 X 1)	4
8	I0124-48273	Cover Rear	1
8A	*I0627-09080	Screw 5/16-18 X 1 3/8"	18
8B	NPT I0566-06790	Plug 1/4-18 NPT	2
9	2061041786	Driveshaft Bushing	1
10	N321006060Z	Screw 6 Pgx60 8,8 Z Iso 1217	1
11	2061048274	Plate Dust Cover	1
12	*I0250-48601	Packing Gland Assy	1
13	*I0165-48284	Gear packing gland (12 teeth)	1
14	2071002188	Retaining Ring	1
15	2061040818	Pinion Gear (2:1)	1
16	2061041787	Shaft	1
18	2061048208	Blocks Bearing	1
19	N3300064Z	Flat Washer D.6	1

Sampi Meters - SM 5

Ordering Information

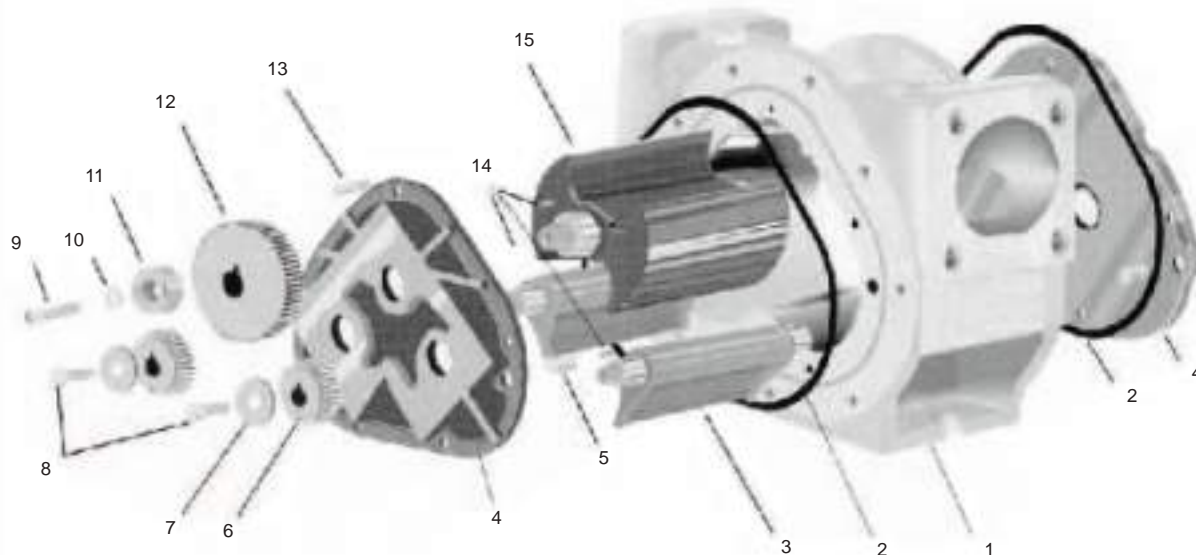

* Contact Liquip for confirmation of spare parts

Meter Element			
Item No	Part No (Class 2)	Description	Qty
1	I0110-501149	Housing	1
2	*I0430-09120	O-ring, viton	2
3	I0155-48976	Displacement Rotor Assy	2
4	I0144-44286	Plate Bearing	2
5	I0318-40665	Pin Dowel	4
6	I0163-49469	Gear displacement pinion	2
7	I0771-48319	Washer Rotor Gear	2
8	I0673-09110	Screw 1/4-20 x 3/4"	2
9	I0675-09336	Screw 1/4-20 x 1"	1
10	I0765-09337	Washer, lock	1
11	I0326-501140	Driver Packing Gland	1
12	I0161-49468	Gear Blocking Rotor	1
13	*I0611-09079	Screw 10-24 x 5/8"	8
14	I0528-48345	Key Stainless Steel	3
15	I0153-48079	Blocking Rotor Assy	1

* Can be supplied only in KIT

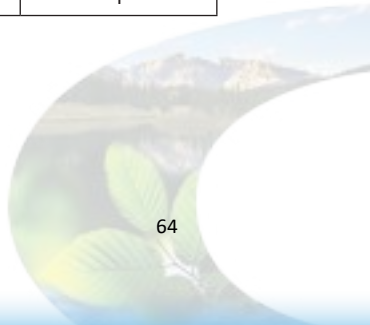

Sampi Meters - SM 30

Ordering Information

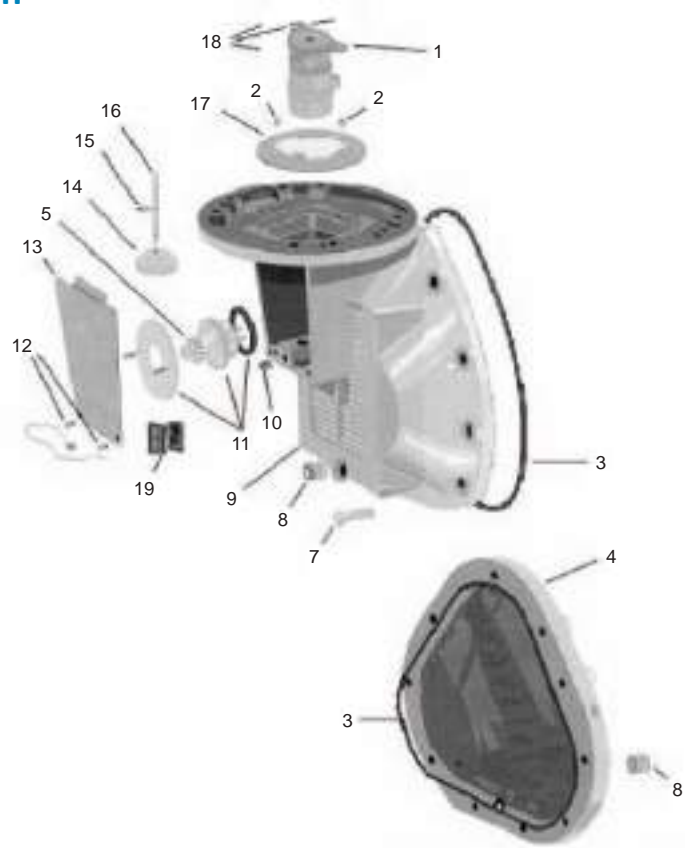

* Contact Liquip for confirmation of spare parts

Cover Assembly			
Item No	Part No (Class 2)	Description	Qty
1	2030045660	Adjuster Assembly	1
2	I0000-00362	Screw	2
3	*I0430-09325	O-Ring	2
4	I0125-44104	Cover Rear	1
5	*I0165-48283	Pinion gear (1:1)	1
7	*I0627-09085	Screw .312-18 x 1,375	22
8	I0566-04759	Pipe Plug	2
9	I0123-44103	Cover Front	1
10	I0603-06703	Screw. 250-20x.250	1
11	*I0250-48601	Packing gland	1
12	*I0630-04494	Screw. 250-20x.250	2
13	I0362-46169	Dust Cover	1
14	2061040122	Pinion Gear 24 teeth	1
15	2071002188	Retaining Ring	1
16	2061041790	Shaft	1
17	I0364-43044	Plate adjuster mounting	1
18	N3280048065Z	Screw	3
19	2061041786	Driveshaft bushing	1

* Can be supplied only in KIT

Sampi Meters - SM 30

Ordering Information

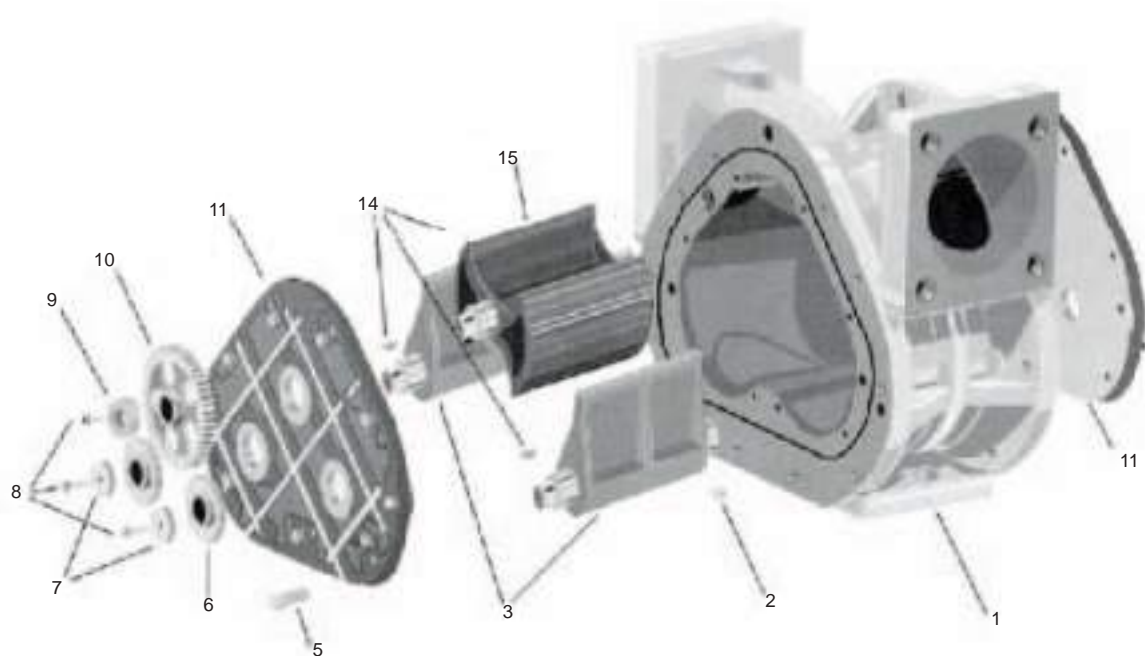

* Contact Liquip for confirmation of spare parts

Meter Element			
Item No	Part No (Class 2)	Description	Qty
1	I0110-44101	Housing	1
2	I0318-40099	Pin Dowel	4
3	*I0155-47575	Displacement Rotor Assy	2
5	*I0611-09098	Screw 1/4-20 unc	16
6	*I0163-47388	Gear Pinion	2
7	*I0771-48348	Washer Rotor Gear	2
8	*I0673-07483	Screw 25-20 x 1.00	3
8°	*I0773-06174	Lock, washer, .250	3
9	*I0326-48844	Driver Packing Gland	1
10	*I0161-47387	Gear Blocking Rotor	1
11	I0144-44102	Plate Bearing	2
14	*I0528-07229	Key Stainless Steel	3
15	*I0153-47574	Blocking Rotor Assy	1

* Can be supplied only in KIT

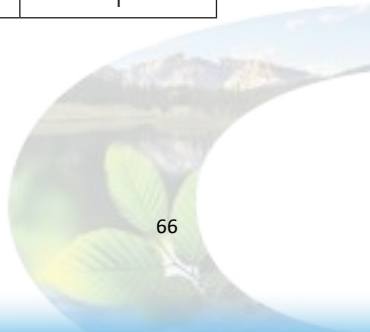

Avery Hardoll BM Series PD Meters

Avery Hardoll bulk meters are precision made, positive displacement, liquid measuring instruments, which maintain accurate metering.

The simplicity of design and construction together with sustained accuracy of an Avery Hardoll bulk meter has led to the widespread use of these meters on aviation refuelling vehicles, in oil terminals throughout the world.

Features & Benefits

- Positive displacement liquid measuring instruments.
- Unequaled performance in measurement to 0.1% accuracy.
- Not affected by outside factors caused by calibration.
- 115 to 3,870 LPM flow rates.
- Accuracy between calibration levels.
- Suitable for use in distribution depots and aviation refueling vehicles.
- Repeatability better than 0.02%.
- Serviceability: designed for quick and easy maintenance



Avery Hardoll BM Series PD Meters

Technical Information

Pressure Ratings	Max working pressure: 150 PSI. Test pressure: 300 PSI,
Temperature Range	-28°C to 100°C.
Maximum Flow Rate	1,370 LPM (82 m3/hr) single capsule. 2,500 LPM (168 m3/hr) double capsule - intermittent. 3,870 LPM (232 m3/hr) triple capsule.
Volume per revolution	2.27 litres (single capsule). 4.54 litres (double capsule). 6.82 litres (triple capsule).
Repeatability	0.02% (typically).
Materials	Manifold: Fabricated steel or ductile iron ductile iron not available on triple capsule meters. Body: Ni-Resist cast iron. Vanes: Carbon. Rotor: Aluminium or Ni-Resist cast iron. Outer Covers: Aluminium or Ni-Resist cast iron. Inner Covers: Ni-Resist cast iron. Bearings: Stainless steel. Seals: High nitrile or fluorocarbon.



Avery Hardoll Electronic Meter Controller

The Avery-Hardoll MASTERLOAD II™ is a versatile micro processor based electronic controller. It is an intrinsically safe system that is ideal for use in Category 2 hazardous areas and is comprised of a pulse transmitter mounted on the meter, a display unit giving readouts of batch volume, flow rate and a totaliser.

Displays of batch delivery, rate of flow and totaliser are given on three large liquid crystal displays that provide readouts of batch volume, flow rate and the totaliser. These displays can be easily configured to show alternative values such as temperature compensated volume and volume to weight conversions.

Additional displays can show repeat or supplementary information at other convenient locations on the refuelling vehicle.

Features & Benefits

- Accurate, dynamic meter calibration.
- Volume to weight conversion.
- Temperature compensation (optional).
- Two-way data interchange to cab mounted data capture systems.
- Interface to deadman system.
- Interface to accessories with 4-20 mA output.
- Flexible installation.



Avery Hardoll Electronic Meter Controller

Technical Information

IP Ratings	All units are designed for outdoor use & are sealed to specification IP 65.	Non-volatile Memory	Infinite data retention.
Security	Full wire sealing. Automatic error checking. Alarm reporting. Data Storage for 40 transactions.	Power Supply	12/24 VDC.
Operating Temperature	-20 to 40° C.	Power consumption	350mA max. (excluding relays).
Transmitter	Temperature: -30 to 120° C. Fitting: Direct drive available. Approval: EN ISO 6551-1995 Level A. Channels: 3 Independent. Security: Sense line.	Relays	Max of 11 plug-in. Typical - 1 Deadman. Pulse output.
Humidity	Resistant up to 100% R.H.	Inputs	4-20mA (4).
Temperature Probe PRT	Accuracy: +/-0.1° C Discrimination: 0.1° C. Range: -30 to 120° C. Set Up: Factory set. Alarm Limits: Programmable. Display: °F or °C. Compensation: 15, 20 or 31.5° C.	Linearisation	1, 2, 4 or 8 selectable. Full dynamic interpolation. Accuracy: +/- .02 @ measuring condition. and 15° C if temperature compensation fitted.
Safety Classification	Category 2.	Manual Input	Density for weight indication.
ATEX Approvals	Power Supply Unit: (flameproof). -II 2 G EEx d IIB T6. -Cert. No. ITS04ATEX11903. Display Unit: -II 2 G EEx ib IIB T4 -Cert. No. BAS02ATEX2199	Product correction tables	IP/ASTM Table Selection to IP65. Generalised crude (A tables). Generalised products. Table 54. Table 53
Delivery Override	Key Operated IP 65 Box (option).	Locations	Flexible mounting: (max 50 meters between units).



Isoil Digital Display - LFD-6

Isoil's new LFD-6 remote display unit has been designed mainly for use on hydrant dispensers and aviation refuellers working at airports. This application requires the volume measured by the PD meter be repeated and easily read from a reasonable distance within the working area.

The LFD-6 nevertheless can be used in any application where the operator is working at a distance from the meter counter and an easily readable display is required. Such typical applications include top loading of tank trucks and rail cars, also loading of barges, ships, etc.

From a metrology standpoint, it is the main meter (and counter) that is the only official metering reference. Therefore, the LFD-6 has to be considered as a simple repeater of the main instrument. The value displayed is received by factorised pulses representing the minimum value to be read (e.g. if the display is required in litres, then 1 pulse=litre). If the LFD-6 is used in conjunction with ISOIL's Vegall or VegaT electronic counter it can be linked via serial line. The LFD-6 has a maximum of 6 digits plus a decimal point that can be programmed in a fixed position. At the end of the delivery the unit can be reset to zero remotely by means of a dedicated input.

The display brightness is achieved by automatic, self adjusting LED which provides very high readability in all lighting conditions. The LFD-6 is suitable for use in explosive areas and harsh environments. ATEX conformity and IP66 protection rating.

Ordering Information

Part No	Description
LFD-6	Remote Digital Display

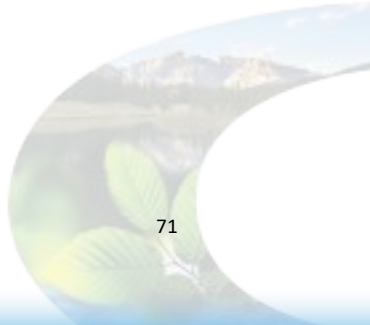

Isoil Digital Display - LFD-6

Technical Specifications

Reading:	N° 6 digit 63(H)x30(L) mm– Red L.E.D. high efficiency type+decimal point
Brightness:	Self adjusting according to the environmental conditions
Unit of measure:	At custom choice by means of labels with the main units of measure
Counting input:	From npn/ pnp open collector transistor or square wave 5-15VDC – 5KHz max
Reset input:	From npn/ pnp open collector transistor or square wave 5-15VDC – 5KHz max
Serial communication:	N° 1 line settable as RS232 or RS485 (communication protocol compatible with ISOIL VEGAI e VEGA T electronic registers)
Mains:	10-30VDC
Power:	10 W max
Working temperature:	-25÷55°C
Stock temperature:	-40÷65°C
Relative humidity:	0÷95% without condensation
Housing's material:	Anodised aluminium alloy
Environmental protection:	IP66
ATEX conformity:	For category II 2 G protection mode Ex IIB T6- EC type examination certificate: INERIS 08ATEX0028
Cable entries (standard):	From the bottom, 2 holes ½" NPT
Cable clamps:	In the bottom side, spring terminals for wires 1,5mmq max
Mounting facilities:	N° 6 screwed holes M6x10 on the back and lateral sides for wall or bracket mounting Equipped with silent block supports
Dimensions /Weight:	388x148x49mm / 5 Kg

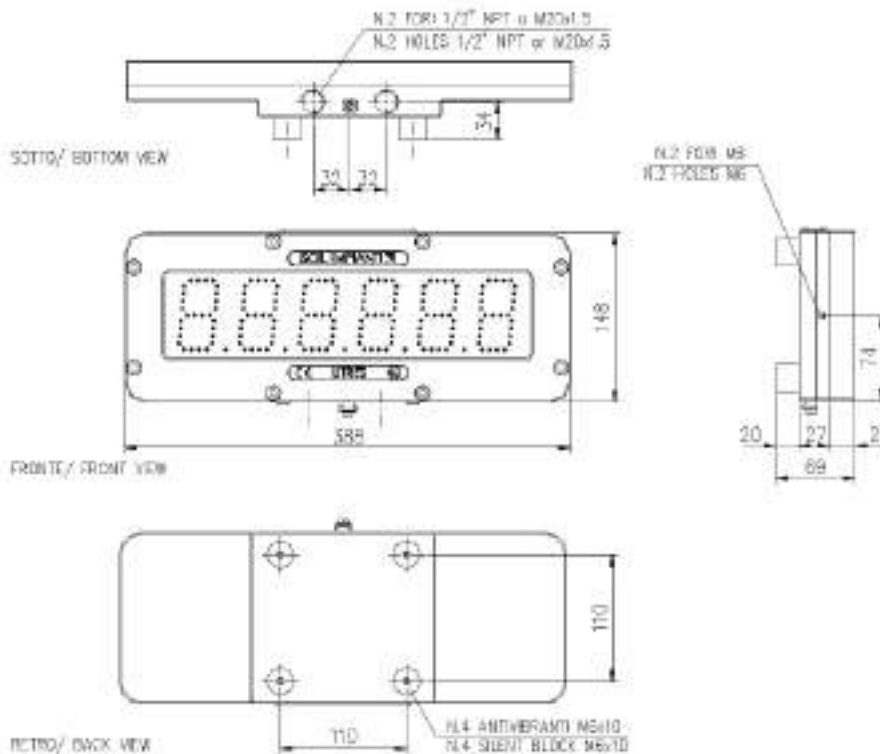

Gorman Rupp Pump 2"

Most economical and best quality pump

Gorman Rupp pumps are proven performers in reliability. Self-priming centrifugal PTO pumps are ideal for handling aircraft fuels. Designed for truck mounting.

Technical Specifications

- Size:** 2" x 2" (51 mm x 51 mm) NPT - Female
- Casing:** Aluminium Alloy 356-T6
Maximum Operating Pressure 234 psi (1613 kPa)*
- Enclosed Type, Six Vane Impeller:** Aluminium Alloy 356-T6 w/Gray Iron 30 Hub Insert
- Pinion Shaft:** Alloy Steel 4320
- Replaceable Wear Ring:** Copper Alloy C93200
- Removable Cover Plate:** Gray Iron 30, 6 lbs. (3 kg)
- Seal:** Type 21, Mechanical, Self-Lubricated. Carbon Rotating Face. Ni-Resist Stationary Face. Fluorocarbon Elastomers (DuPont Viton® or Equivalent). Stainless Steel No. 18-8 Cage & Spring. Maximum Temperature of Liquid Pumped, 160°F (71°C)*
- Seal Guard:** Brass Tubing ASTM B-135
- Gearbox Housing:** Gray Iron 30
- Gearbox Lubrication:** SAE 90 Gear Oil
- Gear:** Alloy Steel 4620
- Gear Ratio:** 5.69:1 Increase
- Bearings:** Open Single Row Ball
- Flanges:** Gray Iron 30
- Gaskets:** Buna-N w/Cork and Vegetable Fiber
- Hardware:** Standard Plated Steel
- Optional Equipment:** Victaulic™ Elbow
Victaulic is a Registered Trademark of Victaulic Company of America

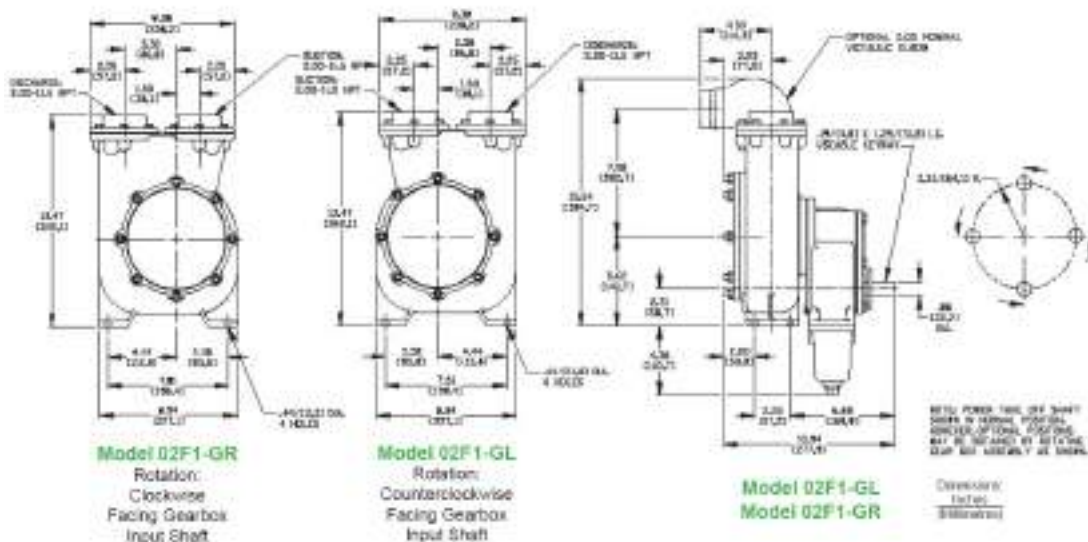

Gorman Rupp Pump 2"

Ordering Information

Part No	Description
8425	Pump Gorman Rupp 2" model 02F1-GR (right-hand rotation)

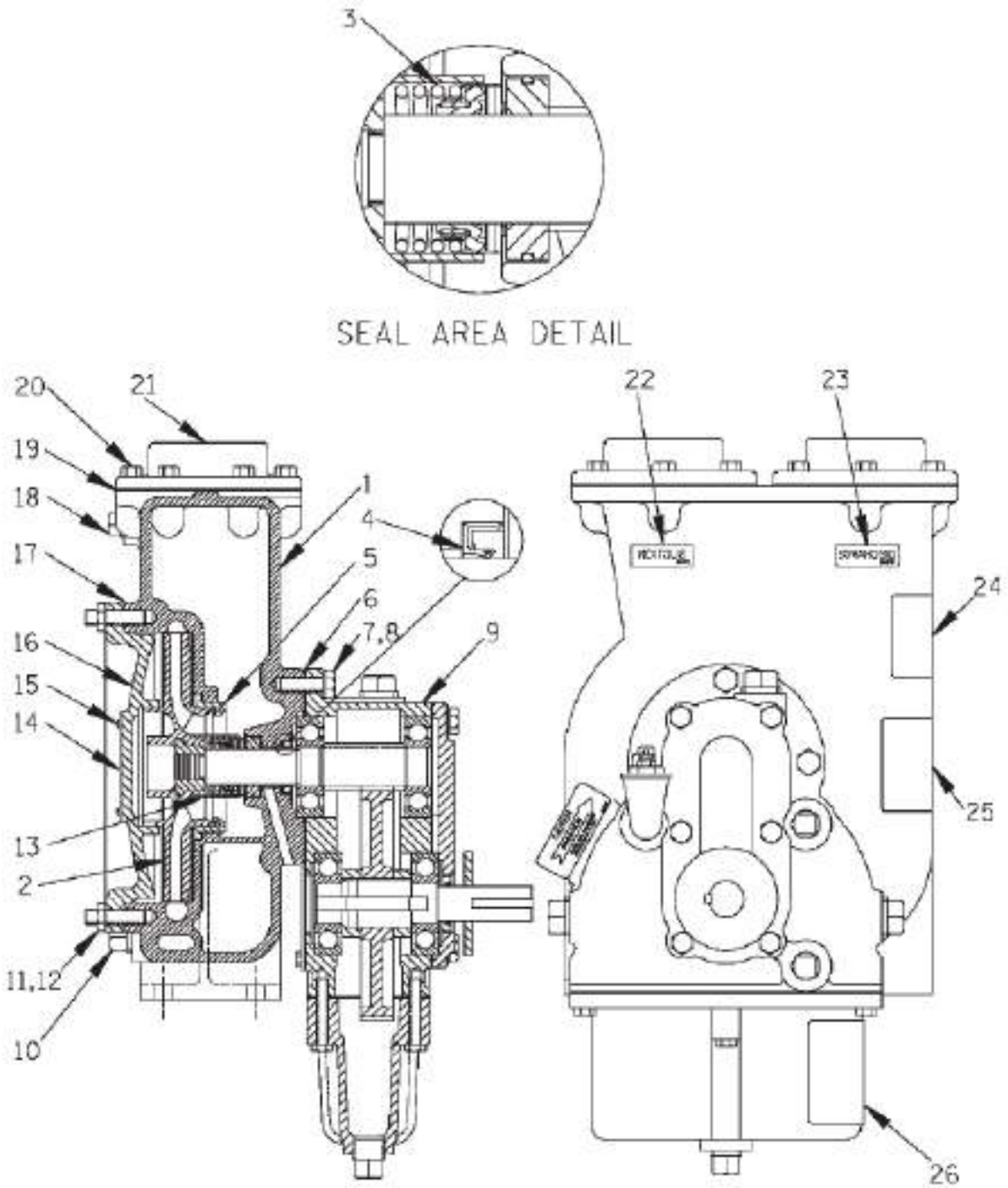

Figure 1. Pump Model 02F1-GR

Gorman Rupp Pump 2"

Ordering Information

If your pump serial number is followed by an "N", your pump is NOT a standard production model. Contact the Liquip part sales team to verify part numbers.

Parts List Pump Model 02F1-GR				
Item		Part No	Description	Qty
1		8751B	Pump Casing	1
2		8101	Impeller	1
3	*	25271-851	Seal Assembly	1
4	*	25217-165	Oil Seal	1
5	*	8099	Wear Ring	1
6	*	8102G	Gasket	1
7		B0604	Hex Head Capscrew	3
8		J06	Lock Washer	3
9		44161-020	Gear Box Assembly	1
10		P06	Pipe Plug	1
11		C0606	Stud	8
12		D06	Hex Nut	8
13		31143-056	Seal Guard	1
14		38818-020	Name Plate	1
15		BM#04-03	Drive Screw	4
16		11156	Cover Plate	1
17	*	8098G	Cover Plate Gasket	1
18		P04	Pipe Plug	2
19	*	9288A	Flange Gasket	2
20		B0603	Hex Head Capscrew	12
21		9586A	Flange	2
22		6588AG	Suction Sticker	1
23		6588BJ	Discharge Sticker	1
24		GR-02	G-R Decal	1
25		38816-077	Gear Lube Decal	2
26		8382B	Lubrication Decal	REF
NOT SHOWN		38817-039	Instruction Tag	1
NOT SHOWN		6588U	Instruction Tag	1

* Indicates parts recommended for stock

Gorman Rupp Pump 2"

Ordering Information

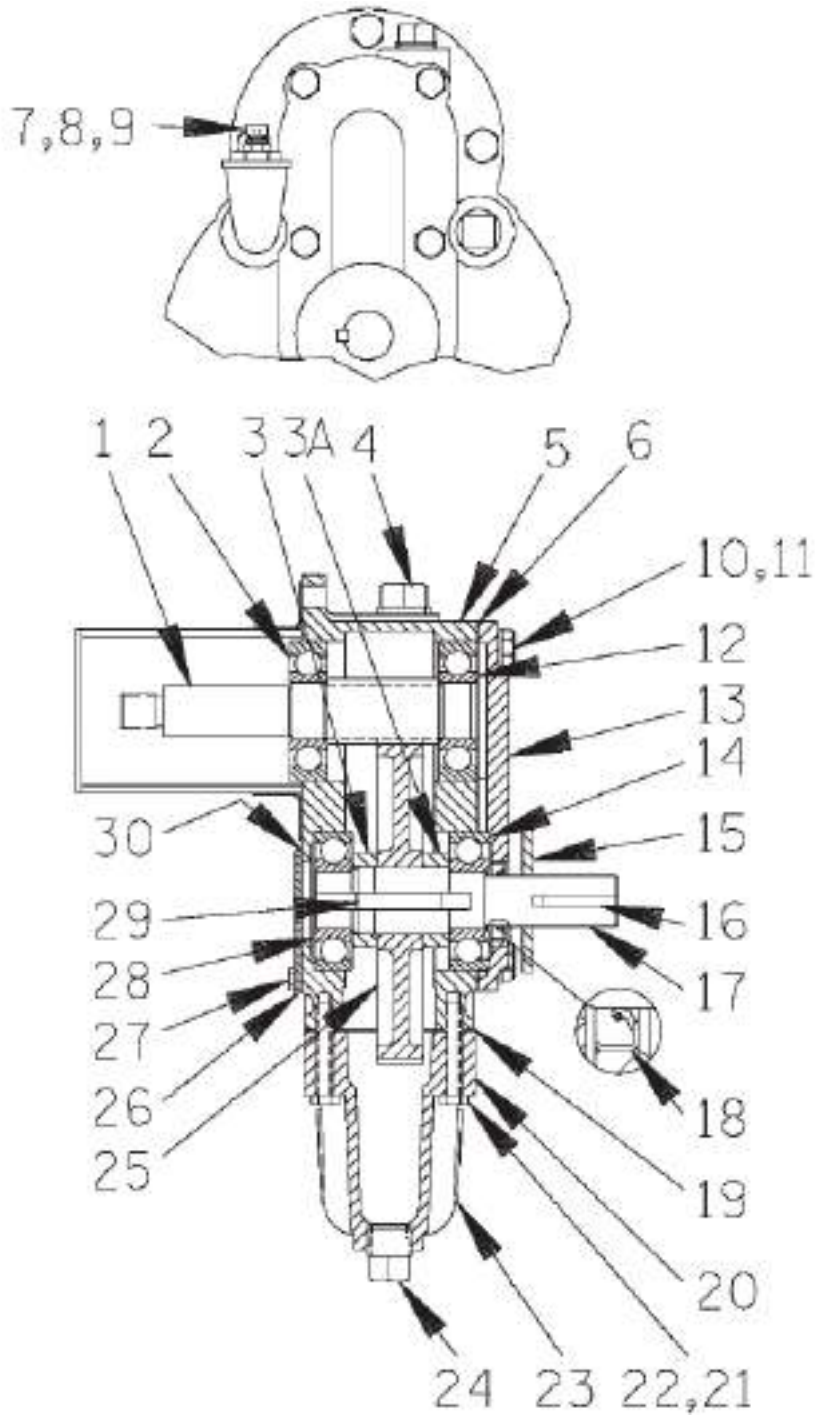

Figure 2. 44161-020 Gear Box Assembly



Gorman Rupp Pump 2"

Ordering Information

If your pump serial number is followed by an N", your pump is NOT a standard production model. Contact the Liquip part sales team to verify part numbers.

Parts List 44161-020 Gearbox Assembly				
Item		Part No	Description	Qty
1		38521-016	Pinion Shaft	1
2	*	23275-206	Ball Bearing	1
3		8104	Spacer Sleeve	2
4		P08	Pipe Plug	1
5		8103B	Gear Box	1
6	*	8097G	Gasket	1
7		S1530	Air Vent	1
8		AP0802	Reducing Pipe Bushing	1
9		RS08	Street Below	1
10		B0503	Hex Head Capscrew	6
11		J05	Lock Washer	6
12	*	23275-206	Ball Bearing	1
13		8097	Bearing Cover	1
14	*	S1120	Ball Bearing	1
15		31131-063	Slinger Ring	1
16	*	N0305	Key	1
17		8095	Drive Shaft	1
18	*	S1617	Oil Seal	1
19	*	10332G	Gasket	1
20		38354-032	Oil Sump	1
21		B0406	Hex Head Capscrew	2
22		B0403	Hex Head Capscrew	4
23		8382B	Decal	2
24		P08	Pipe Plug	5
25		8022	Drive Gear	1
26		8120	Cover Plate	1
27		BW#10-01-1/4S	Hex Head Capscrew	3
28	*	S1120	Ball Bearing	1
29	*	N0506	Key	1
30	*	8120G	Cover Gasket	1

* Indicates parts recommended for stock

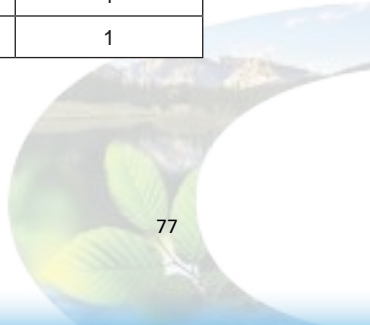

Gorman Rupp Pump 3"

These 3" pumps are used as the product pump on most larger capacity Liquip JET-A aviation refuellers. These Gorman Rupp self-priming product (aviation fuel) pumps are driven by an hydraulic motor on the fuelling module. They pull the product (JET fuel) from the cargo tank and pump into aircraft at around 1,000+ litres / min.

Technical Specifications

Size:	3" x 3" (76 mm x 76 mm) NPT - Female
Casing:	(03H1) Aluminium Alloy 356-T6 (03H3) Ductile Iron 60-40-18 Maximum Operating Pressure 176 psi (1214 kPa)*
Enclosed Type:	Almag 35. Handles 7/16" (11,1 mm) Diameter Spherical Solids
Five Vane Impeller:	
Pinion Shaft:	Alloy Steel 4320
Shaft Sleeve:	Alloy Steel 4130
Replaceable Wear Ring:	Copper Alloy C93200
Seal Plate:	Gray Iron 30, 6 lbs. (3 kg)
Seal Guard:	Copper Alloy C26000
Gearbox Housing:	Gray Iron 30
Gearbox Lubrication:	SAE 90 Gear Oil
Gear:	Alloy Steel 4620
Gear Ratio:	4.09:1 Increase
Bearings:	Open Single Row Ball
Flanges:	(03H1) Aluminium Alloy 356-T6 (03H3) Ductile Iron 60-40-18
Gaskets:	Buna-N w/Cork and Vegetable Fiber
O-Rings:	Buna-N
Hardware:	Standard Plated Steel
Optional Equipment:	Victaulic™ Elbow Victaulic is a Registered Trademark of Victaulic Company of America



*Contact Liquip staff for applications exceeding maximum pressure and/or temperature indicated.

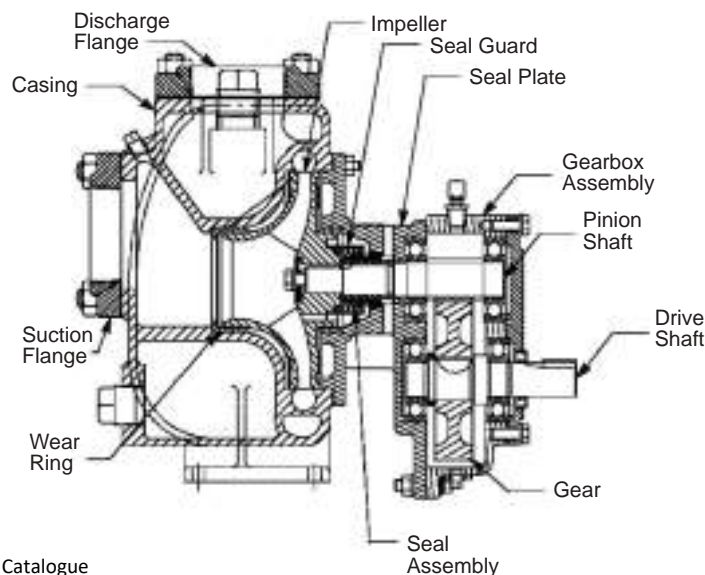

Gorman Rupp Pump 3"

Specification Data

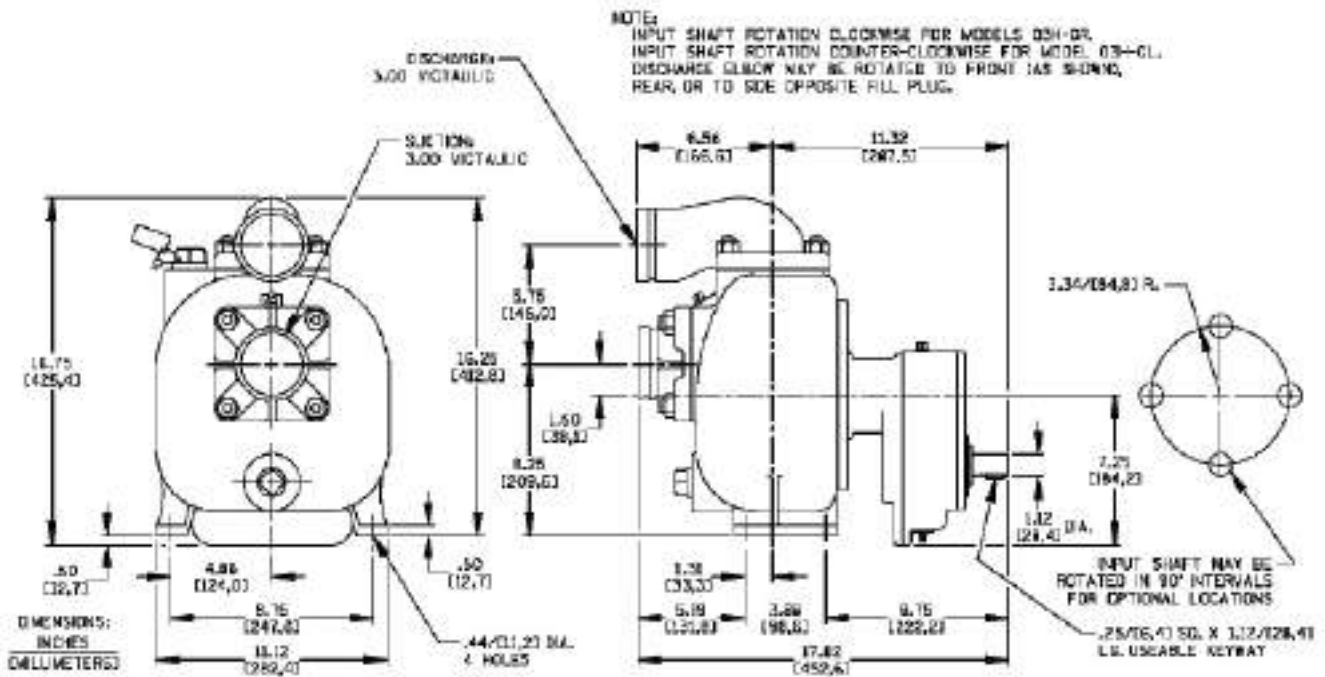
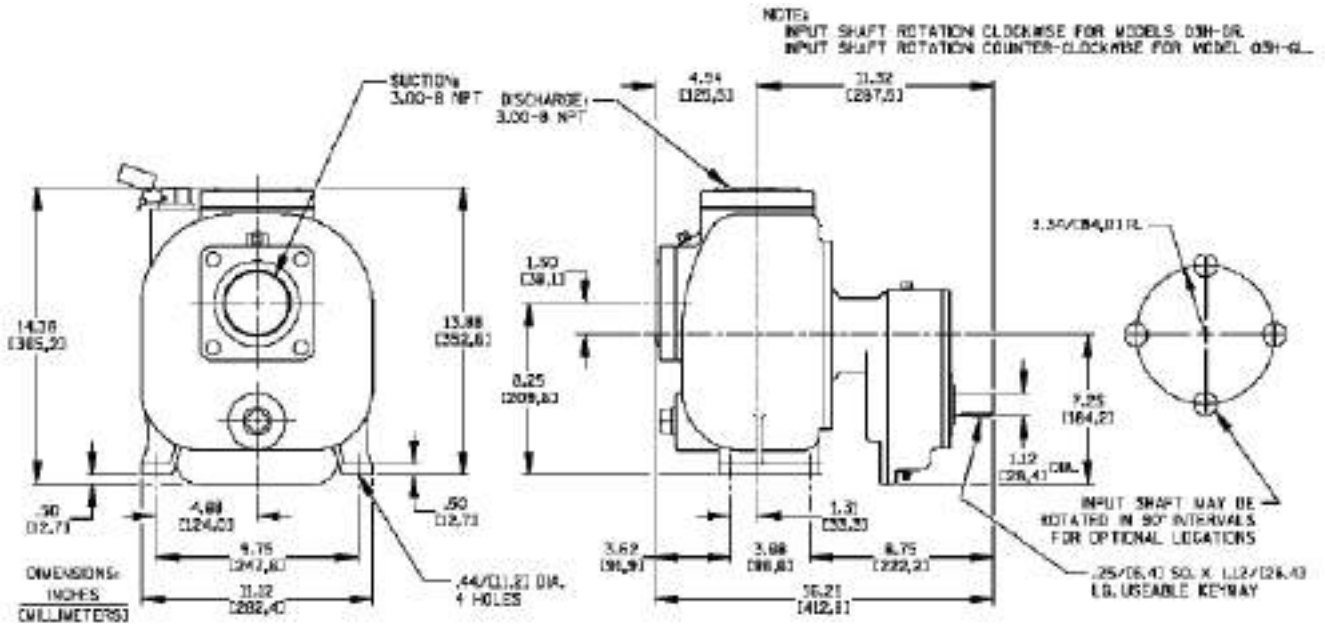

Gorman Rupp Pump 3"

Ordering Information

Part No	Description
8426	Pump Gorman Rupp 3" model 03H1-GR

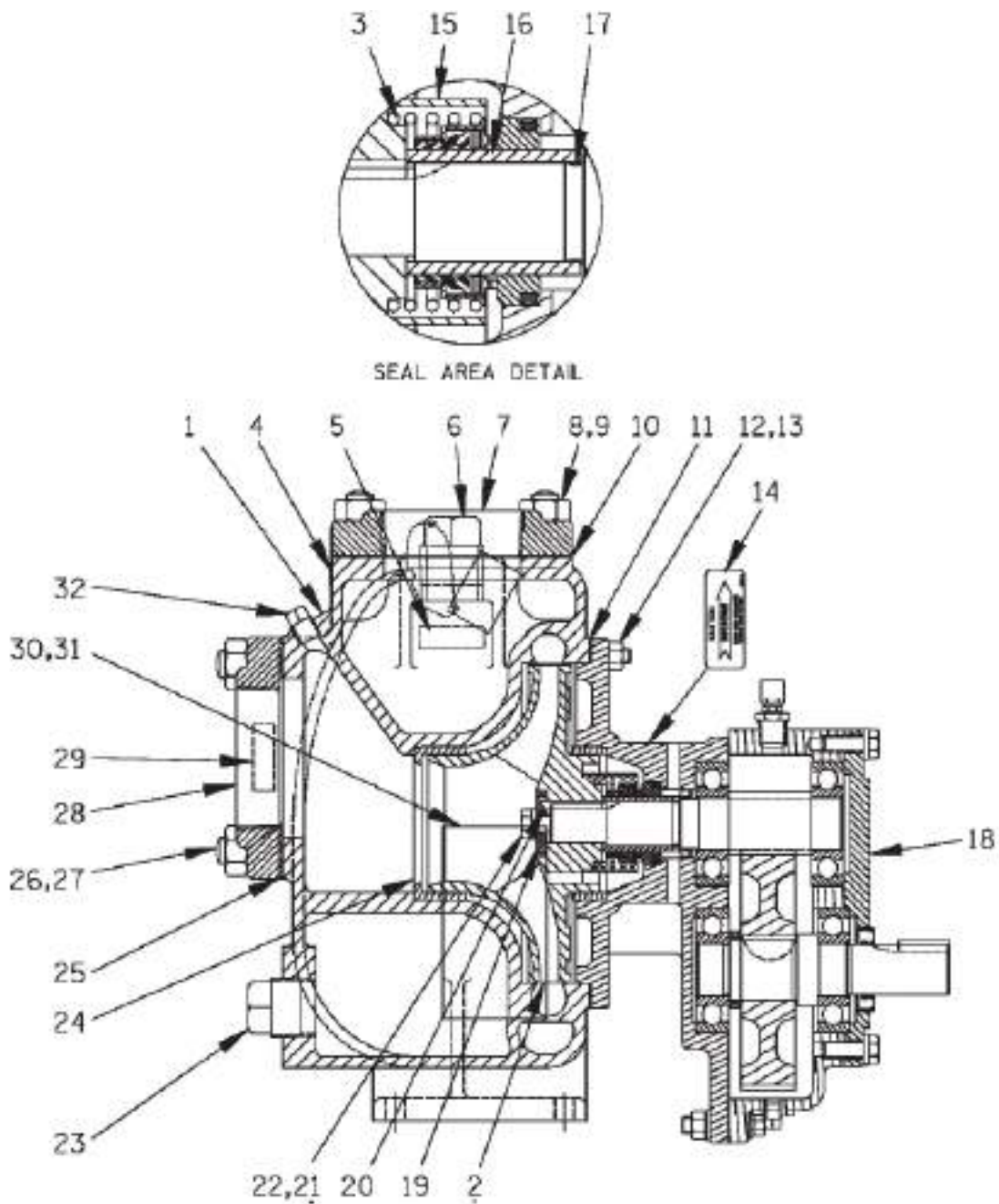

Figure 1. Pump Model 03H1-GR



Gorman Rupp Pump 3"

Ordering Information

If your pump serial number is followed by an "N", your pump is NOT a standard production model. Contact the Liquip part sales team to verify part numbers.

Parts List Pump Model 03H1-GR				
Item		Part No	Description	Qty
1		8274A	Pump Casing	1
2	*	8251A	Impeller	1
3	*	25271-192	Seal Assembly	1
4		6588BJ	Discharge Sticker	1
5		6588AH	FL Here to PRM Stk	1
6		48271-064	Fill Plug Assy	1
7		1390	Discharge Flange	1
8		C1009	Stud	4
9		D10	Hex Nut	4
10	*	1318GB	Discharge Gasket	1
11	*	3GC	Pump Casing Gasket Set	1
12		C0605 1/2	Stud	8
13		D06	Hex Nut	8
14		2613M	Rotation Decal	1
15		9834	Seal Guard	1
16	*	9140	Shaft Sleeve	1
17	*	S1461	Shaft Sleeve O-Ring	1
18		44161-014	Gearbox Assembly	1
19	*	6750	Impeller Washer	1
20	*	N0305-1/2	Impeller Key	1
21		BT0604	Nylock Capscrew	1
22		J06	Lockwasher	1
23		P20	Casing Drain Plug	1
24	*	62ZL5	Wear Ring	1
25	*	1318GB	Suction Flange Gasket	1
26		C1009	Stud	4
27		D10	Hex Nut	4
28		1390	Suction Flange	1
29		6588AG	Suction Sticker	1
30		38818-018	Name Plate	1
31		BM#04-03	Drive Screw	4
32		P04	Pipe Plug	1

* Indicates parts recommended for stock

Gorman Rupp Pump 3"

Ordering Information

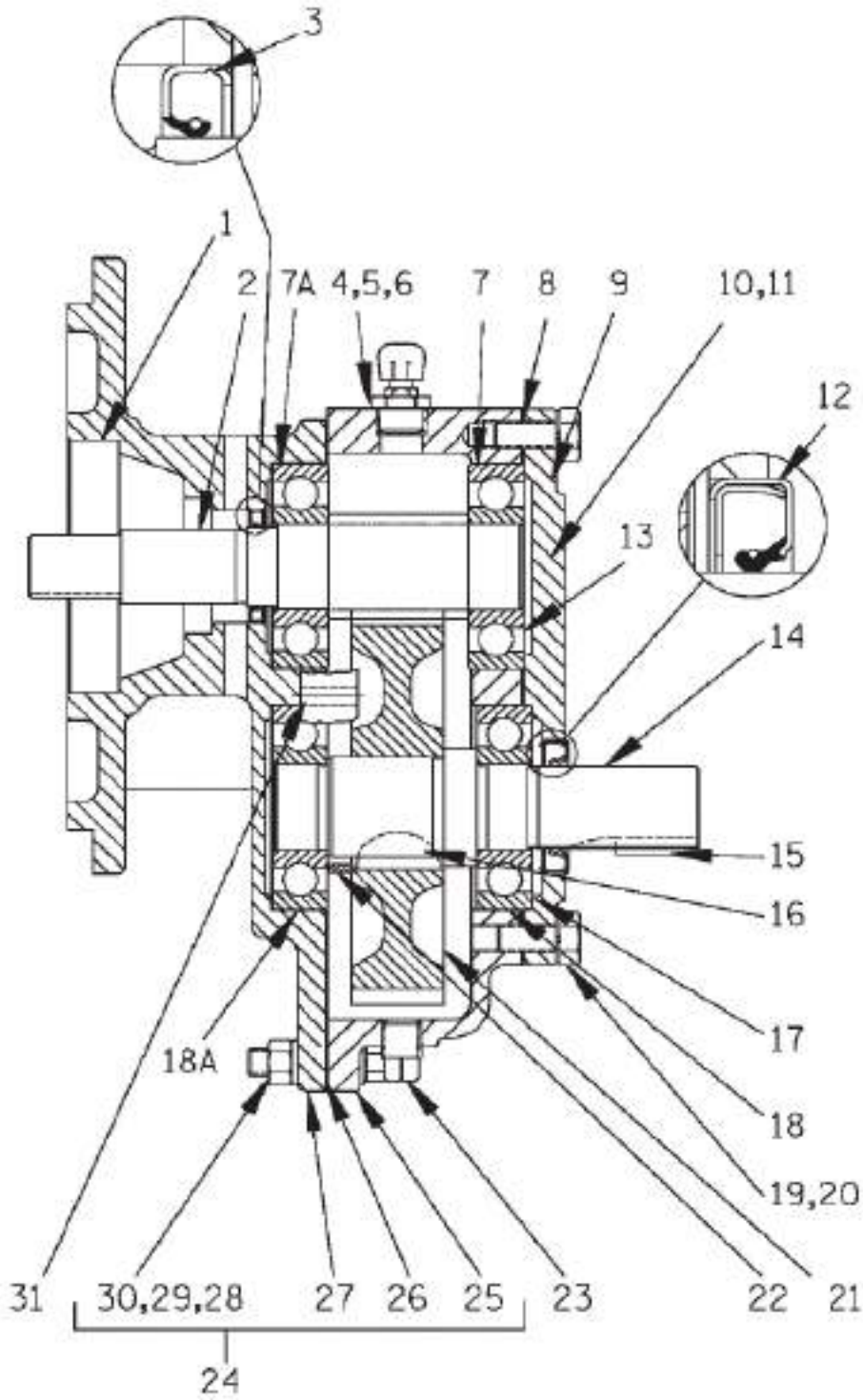

Figure 2. 44161-014 Gearbox Assembly



Gorman Rupp Pump 3"

Ordering Information

If your pump serial number is followed by an "N", your pump is NOT a standard production model. Contact the Liquip part sales team to verify part numbers.

Parts List 44161-014 Gearbox Assembly				
Item		Part No	Description	Qty
1		62ZL6	Wear Ring	1
2		8896	Pinion Shaft	1
3	*	S1764	Oil Seal	1
4		S1530	Air Vent	1
5		AP0602	Reducing Pipe Bushing	1
6		11495A	Shipping Plug	1
7	*	S390	Ball Bearing	1
7A	*	S390	Ball Bearing	1
8	*	8871G	Gasket	1
9		8871	Cover Plate	1
10		38816-239	Lubrication Decal	1
11		2613CQ	PTO Lubrication Decal	1
12	*	S389	Oil Seal	1
13	*	S464	Adjusting Shim Set	1
14		8837	Drive Shaft	1
15	*	N0404-1/2	Key	1
16	*	AV1210	WDF Key	1
17	*	S464	Adjusting Shim Set	1
18	*	S390	Ball Bearing	1
18A	*	S390	Ball Bearing	1
19		J06	Lock Washer	6
20		B0604	Hex Head Capscrew	6
21		8895	Helical Gear	1
22		9142	Spacer Sleeve	1
23		P06	Pipe Plug	5
24		8914	Gear Housing Assembly	1
25	†	NOT AVAILABLE	- Gear Housing	1
26		8870G	- Gasket	1
27	†	NOT AVAILABLE	- Seal Plate	1
28		31871-065	- Flanged Capscrew	8
29		J06	- Lock Washer	8
30		D06	- Hex Nut	8
31		AA0403 -1/2	Dowel Pin	2

* Indicates parts recommended for stock

† Indicates the mating surfaces of items 25 and 27 are machines at the factory for a flush fit. These items are available only by ordering the complete gearbox housing assembly (Item 24).

Portable Aviation Drum Pump

Liquip Portable Aviation Drum Pump refuelling assembly is a complete frame-mounted package, consisting of:

- A hand pump capable of 1 litre per turn
- Velcon VF31 mini-filter and cartridge
- Static reel with cable and clamp
- Hose - 25mm (1") aviation hose (length to suit customer requirements)
- Nozzle - ZVF25.41 manual 25mm (1") bowser-style nozzle with built-in swivel,
- Strainer, dust cap and earth clamp/pin
- Drum Spear suitable for 200 litre drums
- Ground / earth spike

The unit is mounted in a lightweight aluminium frame designed to be free-standing on top of the fuel drum. Filter monitors are last line in defence against fuel contamination by water and dirt. The monitor vessel contains a 6 inch diameter monitor cartridge designed to indicate (by a rise in pressure differential between the inlet and outlet) a problem with water or dirt contamination. The product is pumped under pressure to flow through the housing inlet chamber and "outside-in" through the monitor cartridge. This specially developed multimedia cartridge configuration traps and holds minute solid particles (to less than one micron) whilst absorbing any water contamination, culminating in shutting down the flow if water is present in any volume.

OPTION:

Electric pump in place of hand pump

Ordering Information

Contact the Liquip Sales Department for assistance in determining which of the numerous models and options available will best suit your application.





Fuel Sampling

Millipore Adaptor

The chrome-plated dry break connection is available with a 3/8" BSPP and includes a dust cap. Mainly used for fuel sampling, they are also suitable for a variety of applications including pressure checking and gauge testing.

For pipework, the extension adaptor length of the unit is suitable for 6" pipework and can be cut down and re-angled for smaller pipe diameters.

Technical Information

Design Pressure: 5,000 kPa.

Ordering Information

Part No	Description
MSA011V	Adapt or 3/8" BSPP
MSA011VG	Adaptor 3/8" BSPT - 1/2" BSPP - VITON GFLT
MSF100	Mating female half to 3/8" hose tail

Note: It is recommended to always have an additional valve between the millipore adaptor and the system.



MSA011V



MSA011V

MSF100

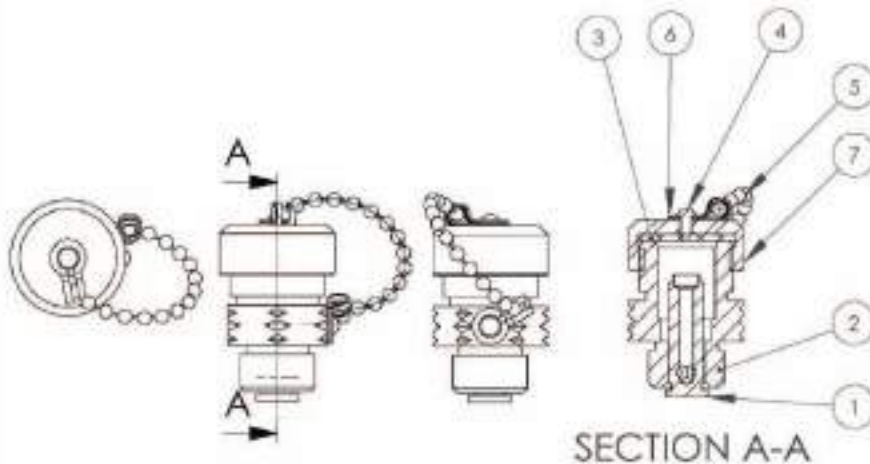

Parts List			
Item No	Part No	Description	Qty
1	MSA010-2	Millipore Adaptor	1
2	MSA011-1	Millipore Sampling Adaptor Body	1
3	6090	Seal - Cap	1
4	6579 (2)	Hammer Drive Screws	2
5	7153 (2)	Chain Bead	1
6	7154	Clip - Bead Chain	2
7	MSA010-3 (2)	Cap for Millipore Adaptor	1

Aljac Sampler

Environmentally acceptable, operationally efficient and safe, eliminating any product loss

Aljac Closed Circuit Samplers have been designed to permit visual examination and full quality control checking of fuel samples within a closed system. A fuel sample is taken by opening the inlet valve and filling the sampler. Visual examination can be completed and the various checks carried out. When the checks are complete, the drain valve is opened and the sample is released into the slops tank.

The Basic Sampler comprises a glass tube, with hinged, vented cover, a cone-down epoxy coated aluminium base, and drain valve with easily operated handle. Fuel enters through a tangential port to promote vortexing which concentrates any impurities.

Accessories are available to permit all currently established methods of water detection, together with density and temperature readings.

Internally: A holder for either Shell Water Detector (SWD) syringe or the Exxon Hydrokit, for suspended water checking.

Externally: A fitting for the SWD syringe at the inlet to the Sampler, adjustable to any angle for convenience. A sample from this point will accurately reflect the condition of the product from which the sample is being taken.



Operation

A fuel sample is taken by opening the inlet valve and filling the sampler. Visual examination can then be completed and the various checks carried out depending on the accessories fitted. When the checks are complete, the drain valve is opened and the sample released either to a dump tank or back to storage.

Features

- Full visual examination
- Elimination of spillage
- Drain to dump/slop tan
- Accessible for internal cleaning
- Suits Density measurement
- Suspended water checking
- Temperature measurement
- Inlet connections: 3/8
- Outlet connections: 1"



ALJAC4

Aljac Sampler

Ordering Information

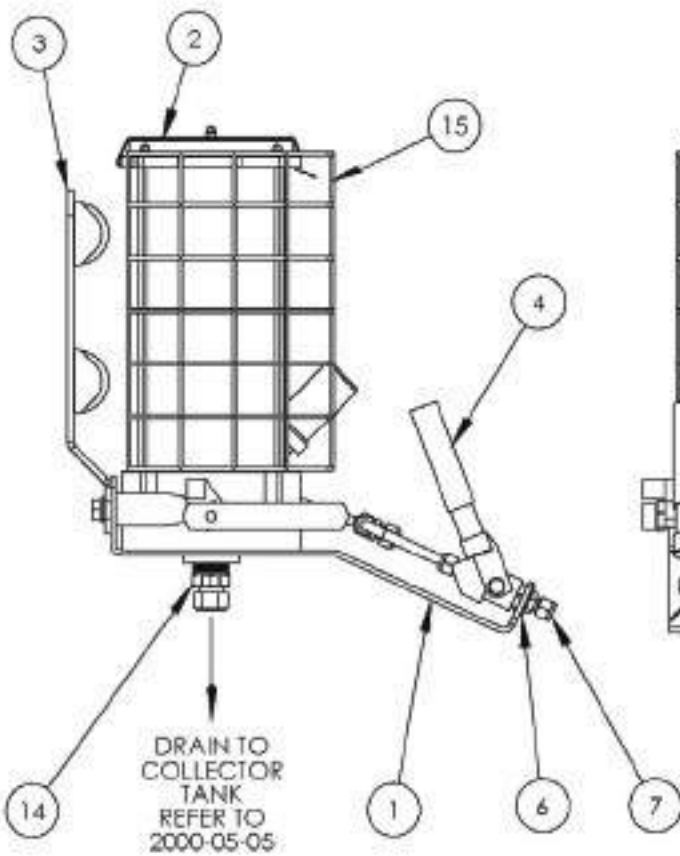
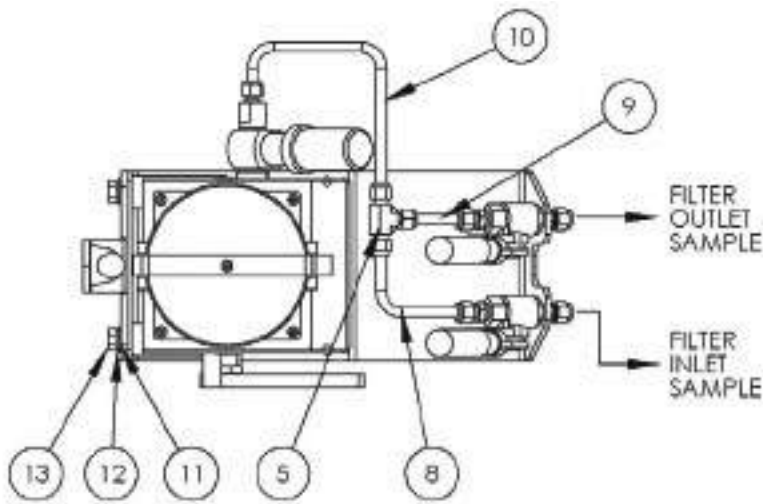

Aljac Sampler

Ordering Information

Item No	Part No	Description	Qty
1	2000-05-01	Bracket Mounting Aljac Assembly	1
2	ALJAC4	Aljac Assembly	1
3	2000-05-04	Post Light Assembly	1
4	8476	Valve Ball 3/8"NPT Apollo	2
5	9049	Tee Tube 3/8" SS	1
6	8622	Washer Flat 16mm ZP	2
7	8648	Fitting Tube Comp. Straight 3/8"NPT x 3/8"T SS	5
8	2000-05-06	Tube 3/8" SS	1
9	2000-05-07	Tube 3/8" SS	1
10	2000-05-08	Tube 3/8" SS	1
11	8620	Washer Flat 12mm ZP	2
12	8618	Washer Spring 12mm ZP	2
13	ZZ0151	Bolt Hex HD M12-1.75P x 30mm ZP	2
14	9036	Fitting Tube Comp. Straight 1"BSP x 3/4"T SS	1
15	2000-05-10	Guard Mesh Frame	1





Overfill Protection

Liquid Detection Probes - LDP Series

Liquip LDP series optic overfill sensors raise the bar in safety with true fail safe technology & individual ‘optic-on’ light.

Liquip’s LDP200 Series liquid detection probes are used as overfill protection on road tankers and in storage tanks. The probes are compatible with existing gantry monitors and interchangeable with current probes. They improve safety with a self-checking design. Probe can be checked for operation independently.

Sensing mechanism used is the different behaviour of a light beam in a glass prism when the prism is wet instead of dry. There is a very large difference in refractive index of air compared with petroleum liquids and this difference provides a very well defined and reliable switching point. With the probe dry, the light beam reflects back internally in the prism and in liquid the beam is refracted out into the liquid and “lost”. Electronics in the probe are designed to create the light beam, detect its return or disappearance and pass that message to the Rack Monitor for appropriate response.



Technical Specifications

Electrical Parameters:

IECEX:	Ui = 30V, li = 690mA, Pi = 9W, Ci = 105pF, Li = 0mH
Operating Temperature:	-40°C to +65°C
IP Rating:	IP66
Level Repeatability:	±0.5mm
Design Pressure:	600kPa

Power Limit (Pi = 9W) applies:

li max = 690mA when Ui max = 13.04V OR
li max = 300mA when Ui max = 30V

Safety Certification

LDP202 and LDP205	• IECEx Certificate:	IECEX ITA 14.0014X
	• Marking:	Ex ia IIA T4 Ga IP66 Tamb = -40°C to +65°C
	• ATEX Certificate	TUV 15ATEX 7627X
	• Marking	CE ₀₅₁₈ Ex II 1 G Ex ia IIA T4 Ga Tamb = -40°C to +65°C
LDP202SS, LDP205SS, LDP202SC, LDP205SC	• IECEx Certificate:	IECEX ITA 14.0014X
	• Marking:	Ex ia IIA T3 Ga IP66 Tamb = -40°C to +65°C
	• ATEX Certificate	TUV 15ATEX 7627X
	• Marking	CE ₀₅₁₈ Ex II 1 G Ex ia IIA T3 Ga Tamb = -40°C to +65°C

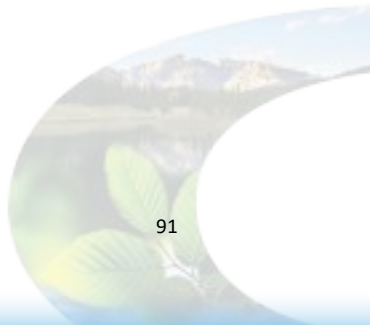

Liquid Detection Probes - LDP Series

MATERIALS	<ul style="list-style-type: none"> Aluminium probe body, retainer & extension OR Stainless steel body, retainer & extension, Pyrex glass prism, and epoxy. Viton o-rings OR FFKM o-rings
MAINTENANCE	Irreparable item, no routine maintenance required, replace with new if found faulty.
INSTALLATION	<ul style="list-style-type: none"> It is the requirement of the ATEX Approval that the probe is installed in such a way that the probe is Electrostatically Grounded. Install the grub screw in PJB500, PJB301 & VOH200-5 kit for this requirement. It is recommended to use Liquip PJB500, PJB301 or VOH200-5 Probe Holder which is compatible with Liquip manhole covers. Probe can be removed from tank top without having to access interior to remove a hood. Installation should be in accordance with APPLICABLE standards SUCH AS EN60079-14 and EN60079-25 or IEC60079-14 and IEC60079-25 or ANSI/ISA RP12.06.01 and ANSI/NFPA 70 or CSA C22.1 Part 1, Appendix F or EQUIVALENT. Users shall avoid ignition hazards due to impact or friction on the apparatus when used in Zone 0 areas. Any free ends of cable not terminated shall be appropriately terminated to ensure no contact with additional sources of power is possible.
WIRING METHOD	<ol style="list-style-type: none"> 2 - Wire System for LDP202, LDP202SS and LDP202SC Attached drawing shows a typical 6 channel compartment system based on Australian Standard. For 8 channel compartment system ask Liquip for more details. 5 - Wire System for LDP205, LDP205SS and LDP205SC Attached drawing shows a typical 7 compartments tanker, the number of probes varies with the number of compartments in the tanker as the probes are connected in series.
OPERATIONAL PARAMETERS	<p>Liquid properties must conform to the following:</p> <ul style="list-style-type: none"> Have refractive index between 1.10 and 1.47. If in doubt, carry out test with sample of liquid at working temperatures. Not be reflective (e.g. milk will not trip probe as white reflects) Be non-gelling and remain liquid at all operational temperatures. Viscosities up to 3500 cSt, work without suffering from clingage. No particles in suspension which can form clinging opaque surface coating on prism. Use with standard petroleum products and water-based compounds only. Any other chemical content must be checked with Liquip. Not allow sunlight to access prism during operation. Not install probe, or carry out routine tests adjacent to any reflective surface. (Incident light and reflections may cause false readings)
HANDLING PRECAUTIONS	<p>Treat with care in particular protect tip until probe is installed. Protect open end of probe from moisture and chemicals. The probe prism is protected and light-shielded by the retainer.</p>
ACCESSORIES	<p>Extension bars of aluminium or stainless steel to suit various length applications. The following extension bars can only be used:</p> <ul style="list-style-type: none"> LDP102-4 (80mm long) LDP102-4SS (80mm long Stainless Steel) LDP102-8 (Gauged, 80mm long) LDP105-2 (222mm long) LDP105-2SS (222mm long Stainless Steel) Note: LC99 extension bar is not compatible.
ASSOCIATED EQUIPMENT	<ul style="list-style-type: none"> RM100 Series Rack Monitor TP Series "Ground Boss" truck plug DP305 Dummy Probe DP307 Dummy Probe PJB301 Probe holder PJB500 Probe holder VOH200-5 Probe holder



Liquid Detection Probes - LDP Series

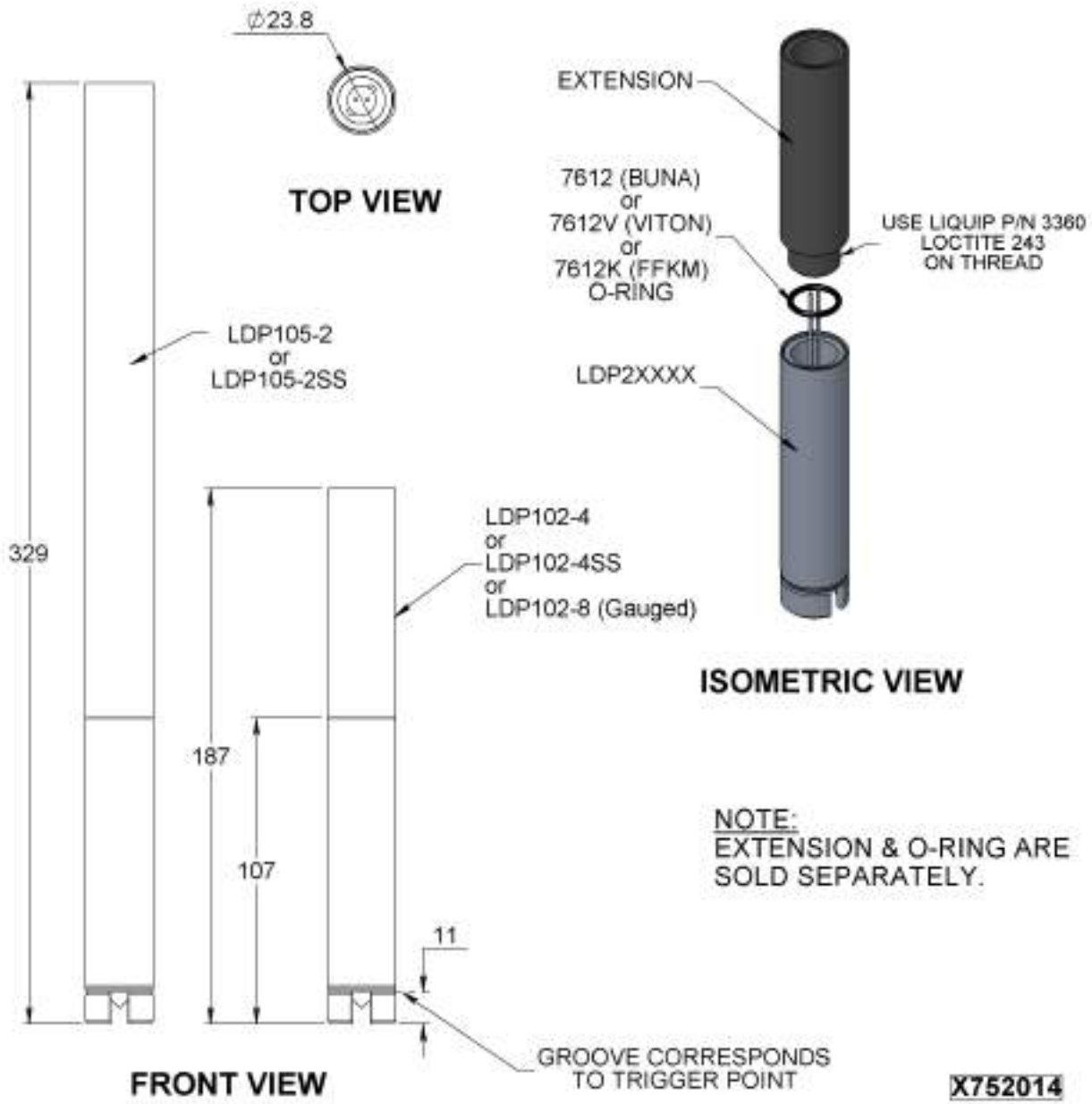

X752014
Issue: C

Ordering Information

LDP202	2 Wire Probe, Aluminium Body	LDP202SCZ	2 Wire Probe, SS Body, Chemical Trim, Kit - Kalrez Seals
LDP205	5 Wire Probe, Aluminium Body	LDP202SSZ	2 wire Probe, SS Body, Kit - Viton Seals
LDP202SS	2 Wire Probe, SS Body with Viton Seals	LDP202XLZ	2 wire Probe, Aluminium Body, Kit with LDP105-2 Long Extension
LDP205SS	5 Wire Probe, SS Body with Viton Seals	LDP202Z	2 Wire Probe, Aluminium Body, Kit - Buna Seals
LDP202SC	2 Wire Probe, SS Body with FFKM Seals	LDP205SCZ	5 Wire Probe, SS Body, Chemical Trim, Kit - Kalrez Seals
LDP205SC	5 Wire Probe, SS Body with FFKM Seals	LDP205SSZ	5 Wire Probe, SS Body, Kit - Viton Seals
		LDP205XLZ	5 Wire Probe, Aluminium Body, Kit with LDP105-2 Long Extension
		LDP205Z	5 Wire Probe, Aluminium Body, Kit - Buna Seals

Probe Holders

Probe Holder - PJB500

The PJB500 is a walkway or manhole cover mounted overfill probe holder.

It includes 2 x M20 conduit thread ports.

The PJB500 provides a protected, clean and dry environment to mount overfill probes to tanker walkways.

Specifications

- Housing can be mounted through a hole and sealed with the locknut or screwed directly into a M60 X 2 thread.
- By removing the top cover, access can be gained for height adjustment of the probe or to the wiring connections.
- The body has two M20 x 1.5mm entries. This eliminates the need to mount a tee with cover in the conduit line. This will allow for better connections and easier fault finding.
- The probe can be adjusted by loosening the internal capscrew to release the clamp and sliding the probe up or down to the correct sensing height.
- Will accommodate probe diameters of 24mm (such as Liquip LDP style).
- Plate thickness for mounting is from 4 to 17mm.
- Overall height when mounted is 96mm, overall diameter is 110mm.
- Housing rated IP66.



Probe Holder - VOH200-5

The VOH200-5 is a lightweight aluminium junction box for direct mounting to “VOH” manhole covers, or via a weld flange VRB-13 direct to the tank top.

Ordering Information

Part No	Description
PJB500	Probe Holder 2” male BSPP
VOH200-5	Probe Holder



On Board Monitor

The Liquip/OPW ROM III (Model Series 3308-LIQZ) is a liquid cargo mounted On Board Monitoring (OBM) System providing intrinsically safe connections for sensors mounted in the top and bottom of each tank compartment.

The ROM III monitor detects and communicates the sensor status and overall unit's "permissive to load" (the tanker) status to a loading rack monitor via its socket outputs. The ROM III is powered by connection to the truck battery.

Specifications

Max Voltage: 30VDC

Max Current: 1.0A

Ambient Temperature range: - 40 to + 70 Deg C (IECEX)

Temperature class: T4 (IECEX)

Gas Group: IIB (IECEX)

Ingress Protection: IP54

Materials of Construction:

Certification: EN IEC 60079-0: 2018; EN 60079-11: 2012; EN 60079-15: 2010; FM approved and IECEX approved

Ordering Information

Part No	Description
3308-LIQZ	: ONBOARD OVERFILL MONITOR ROM III (ZONE 2 IECEX APPROVED) C/W TERMINATOR

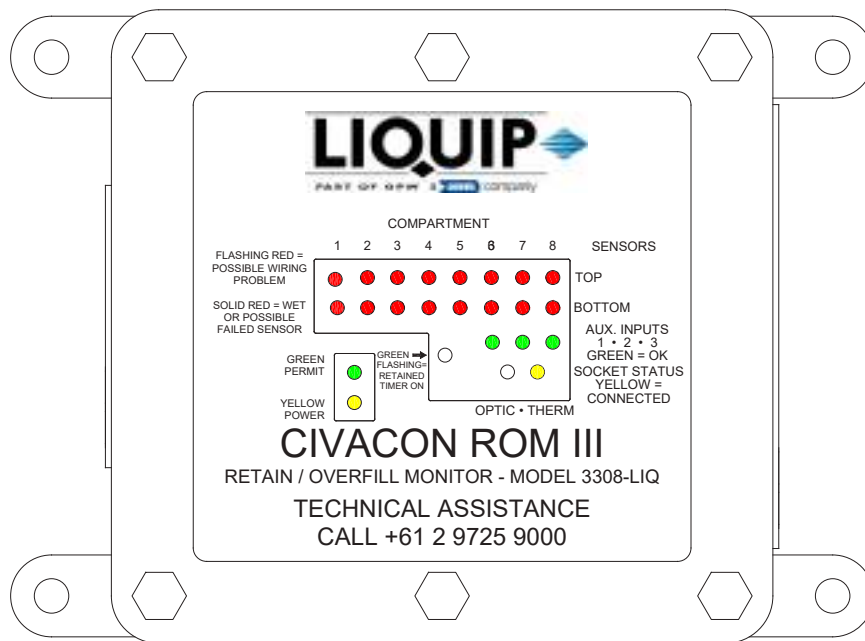



Valves

Non-Return Valves - NRV80

LIQUIP NRV80 sandwich type non-return Valve is typically fitted between standard 3" TTMA or 80mm DIN pipeline flanges, predominantly in aviation Refuellers. Special contoured and shaped valve to allow minimum pressure drop under full flow condition. Immediately after the flow ceases the valve shuts, preventing product from draining back down the pipeline.

However should a pressure build up occur due to temperature increase and expansion, the valve is fitted with a small thermal relief valve to guard against over pressurisation.

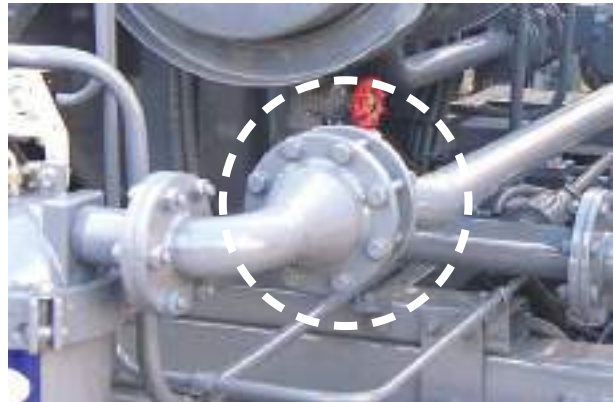

Technical Specifications

- Special Features:** No gasket required. O-rings are used for positive sealing. Thermal relief valve. Full flow.
- Materials of Construction:** Aluminium body, poppet, spider and washer. All viton seals and o-rings. Stainless steel shaft screws and springs. Suitable for aviation fuel.

Main poppet opens at a pressure of 0.9 kPa.
Vacuum poppet opens at a pressure of 350 kPa.

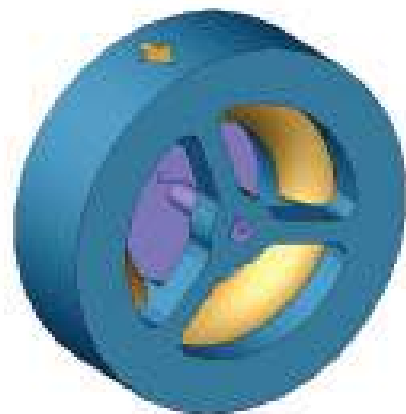
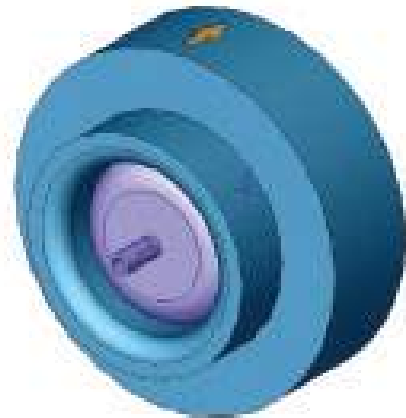

Non-Return Valves - NRV80

Ordering Information

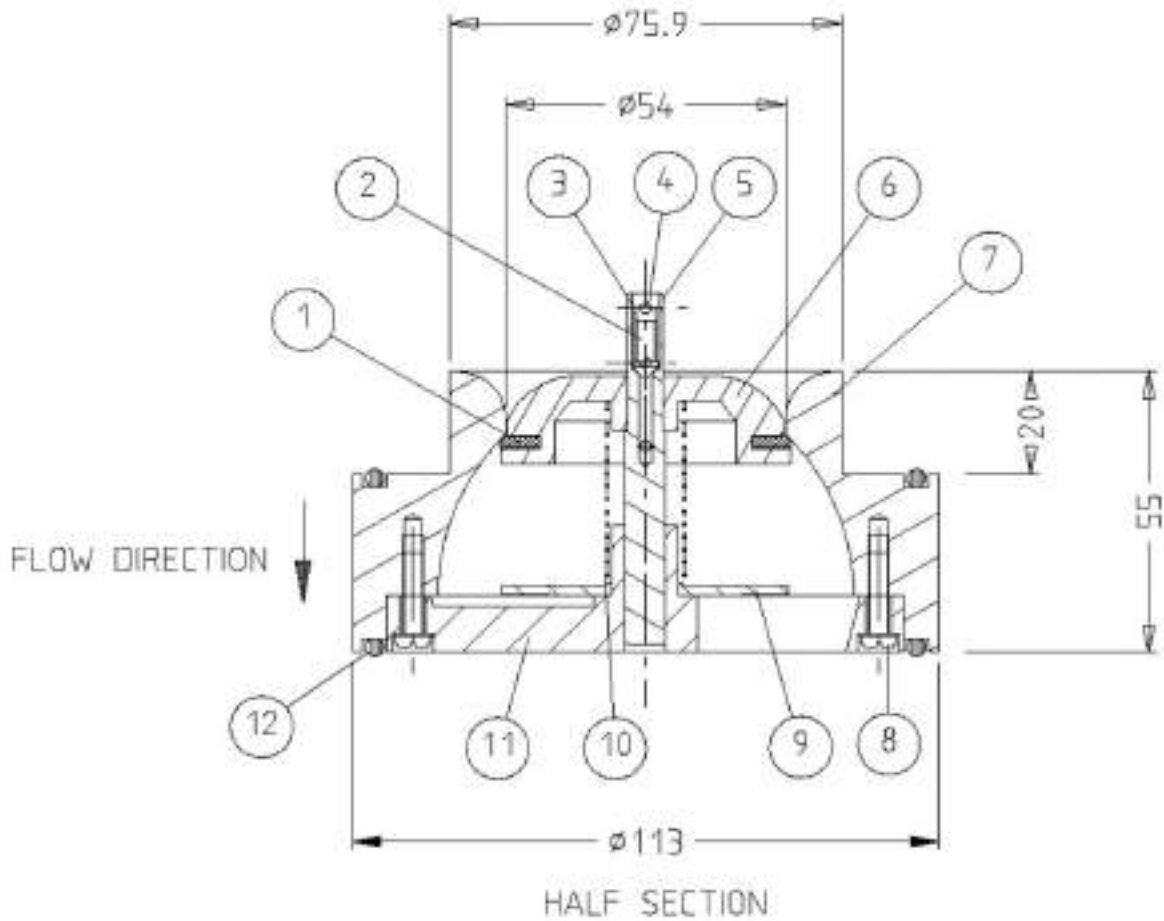

Item No	Part No	Description	Qty	Material
1	4623	Seal Main	1	Viton
2	4624	Seal Vacuum	1	Viton
3	6110	Spring Vacuum	1	S/S
4	0756	Pin Cotter 1/16" x 1/2"	1	S/S
5	NRV80-1	Shaft	1	S/S
6	NRV80-2	Poppet	1	Aluminium
7	NRV80-3	Body	1	Aluminium
8	6464	Screw M4 x 16LG Pan/HD Slot	2	S/S
9	5316	Washer	1	Aluminium
10	6111	Spring Poppet	1	S/S
11	NRV80-4	Spider	1	Aluminium
12	4626	O-ring	2	Viton

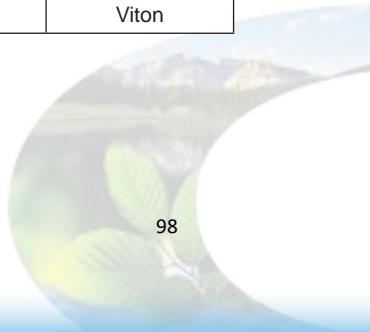

Stainless Steel Flanged Ball Valves

These ball valves are 2-piece stainless steel floating ball type valves with Teflon trim.

Our range of flanged ANSI150 Lb. stainless steel ball valves incorporate a fire safe design which features:

- Blow out-proof stem
- Secondary metal seat
- Metal to metal seal



Ordering Information

Part No	Description
9657	1 1/2" S/S Flanged Ball Valve
9952	2" S/S Flanged Ball Valve
9656	3" S/S Flanged Ball Valve
9655	4" S/S Flanged Ball Valve



Small Isolation Ball Valves

These in-line ball valves are 2-piece either stainless steel or nickel-plated brass double-female BSP valves & Teflon trim.

Ordering Information

Part No	Description
9019	1/4" BSP Ni-plated Brass Ball Valve
0365	1/2" BSP Ni-plated Brass Ball Valve
0366	1/2" BSP Ni-plated Brass Ball Valve
0367	3/4" BSP Ni-plated Brass Ball Valve
8479	3/8" S/S Two Piece Ball Valve
8498	1/4" S/S Two Piece Ball Valve
TS2005	2 1/2" Two Piece Ball Valve



Apollo Valve

The "Apollo"™ whilst a registered Brand name has become a generic term for spring-loaded / return or "deadman" pull-down handle valves. They are in a variety of sizes.

Ordering Information

Part No	Description
8476	3/8" BSP S/S Construction
8477	1/2" BSP S/S Construction
8585	3/4" BSP S/S Construction
8584	1" BSP S/S Construction
8586	1 1/2" BSP S/S Construction
8590	2" BSP S/S Construction

N.B. NPT versions are available by special order



Tank Compartment Internal Drain Valve

The ITV1-AO 25mm internal valve with integral elbow, has been designed for use on aircraft refueller tankers which have small sample or drain lines. The normal fitting in the sump is a 25mm BSP socket. Flow is outwards only. The elbow incorporates a shear groove above the pipe attachment aperture to ensure a breakaway (in the event of damage) at that point.

Valve poppet, spring and shaft are all attached above the shear point to ensure the continued containment of product in the tank. In the event of fire the air line will soften at 80 degrees C and release any air in the system and close the poppet.

Ordering Information

Part No	Description
ITV1-AO	Internal Valve Air Operated



Tank Compartment Internal Drain Valve

Ordering Information

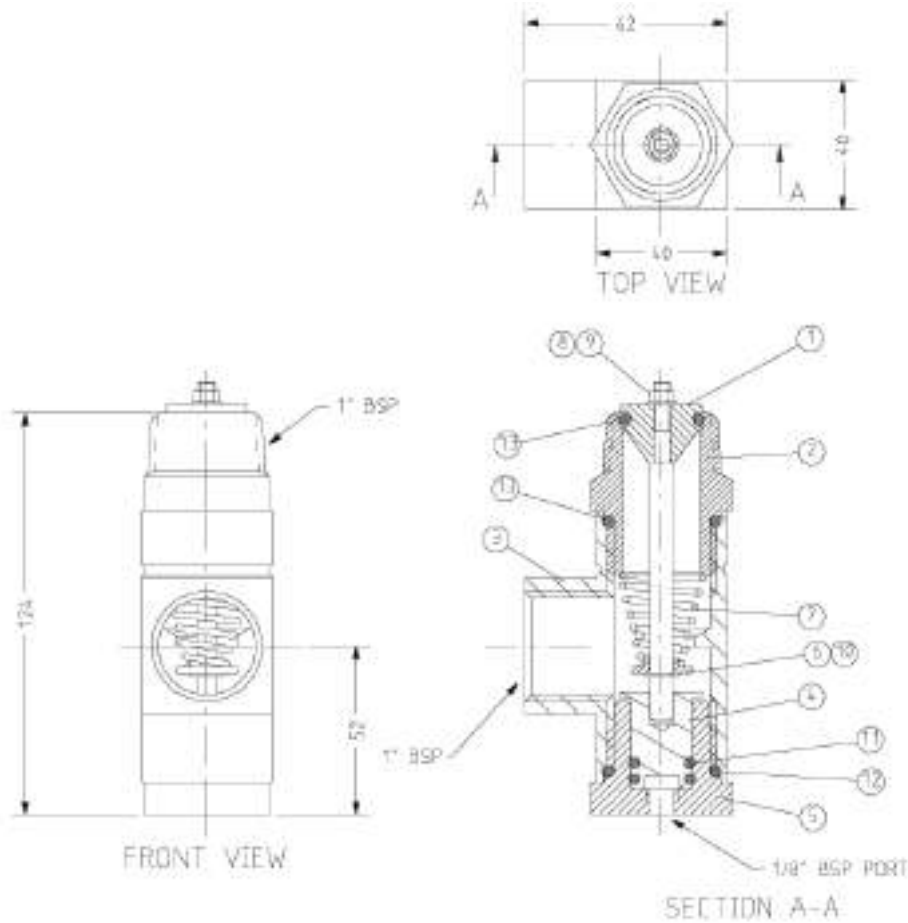

ITV1-AO (Parts List)				
Item No	Part No	Description	Qty	Material
1	ITV1-1	Poppet Assembly	1	AL
2	ITV1-2	Valve Seat	1	Steel
3	ITV100-1	Body Valve	1	Aluminium
4	ITV100-2	Piston	1	Delrin
5	ITV1-5	Cylinder End	1	Steel
6	ITV1-6	Step Washer	1	St Steel
7	4411	Spring	1	St Steel
8	4380	Nut	1	St Steel
9	0809	Washer	1	St Steel
10	4517	E-Clip	1	St Steel
11	0288	O-Ring	2	Viton
12	0171	O-Ring	2	Nitrile
13	0252	O-Ring	1	Viton

ATS Tank Sump

- Aluminium conical tank sump with sloping bottom and central 1" female BSP socket for drain.
- Large capacity volume.
- Removable bottom plate to facilitate cleaning.

Associated Equipment: ITV1-AO pneumatic sampling valve.

Ordering Information



Tank Sump	
Part No	Description
ATS100	ATS Tank Sump

Parts List		
Item No	Part No	Description
1	ATS100-1	Aluminium Sump
2	1530	O-ring Buna
3	ATS100-2	Aluminium Weld Flange
4	4947	Setscrew
	5261	Washer

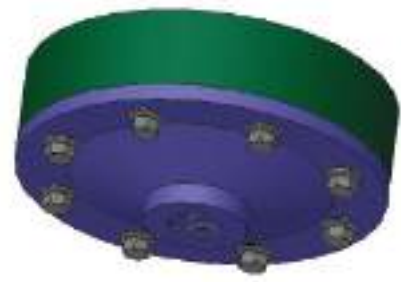
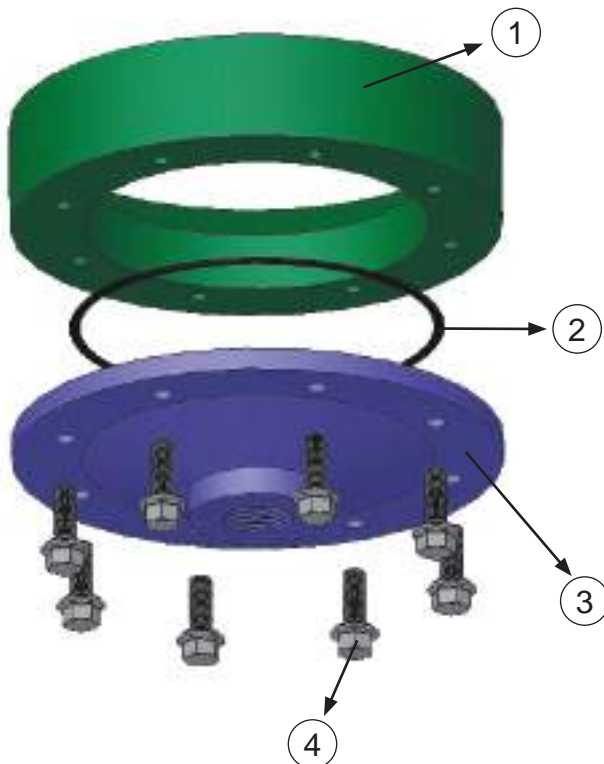



Gauges

Shultz Differential Pressure Gauges

Schultz Engineered Products Model SC-5150 Direct Reading piston type differential pressure indicator is designed to accurately and reliability read differential pressure across filter vessels. The gauge consists of a spring corrosion resistant piston moving inside an annealed glass cylinder. Differential pressure is easily read from the top of the piston.

Key Features

- Glass Cylinder Pressure tested to 1200 psi, To provide a safety factor of 4 at max operating pressure of 300 psi.
- Thermal expansion characteristics of piston and cylinder are matched so binding does not occur during temperature variations.
- Eliminates 3 way manifold and subtraction method of determining differential pressure.
- Design provides automatic dampening against pressure fluctuations so calibration will not be affected.
- Easily changed 10 micron filter on high pressure side of gauge protects internal components.
- Housings available in black anodized aluminum or stainless steel.
- 0-15 psi or 0-30 psi Differential Pressure indication ranges available.
- Extremely Rugged housing protects internal components, acceptable for sustained vehicle usage.
- Optional flush mount unit available for panel installations.



Technical Information

- **Pressure:** 300 psi max operating.
- **Temperature:** -40°C to + 71°C (-40°F to + 160°F).
- **Accuracy:** Accurate within 1/2 psi.
- **Fittings:** 1/4" NPT.
- **Seals:** Viton.
- **Materials in Contact with Fuel:** Aluminium, Stainless Steel, Glass, and Viton (for S/S model delete aluminium).

Ordering Information

Part No	Description
SC-5150-15-KPA	DP GAUGE SCHULTZ 0-15 PSI (0-100kPa) C/W UV OPTION A, 3 WAY VALVE AND ¼" NPT PLUG
SC-5150-30-E-CC	DP GAUGE SCHULTZ 0-30 PSI (0-200 kPa) COLD CLIMATE-VITON GFLT SEALS C/W UV OPTION A, 3 WAY VALVE & ¼" NPT PLUG. FITTED WITH VITON GFLT SEALS
SC-5150-30-KPA	DP GAUGE SCHULTZ 0-30 PSI (0-200kPa) C/W UV OPTION A, 3 WAY VALVE AND ¼" NPT PLUG
SC-5158-30-KPA	SCALE 0-30KPA SCHULTZ DP GAUGE
SC-5169	DP GAUGE SCHULTZ 10MICR FILTER FITS DP GAUGE SC-5150

Pressure Gauges

These gauges are designed to resist pulsation, shock, vibration, weather and most corrosive atmospheres. Fluid medium which does not clog connection port or corrode 316 stainless steel.

Technical Specifications

Accuracy

± 1% of Span (Grade A ANSI B40.1)

Ranges

0-1000 kPa/psi and 0-1600 kPa/psi

Operating temperature

Ambient = -20°C to 60°C

Media: max. +85°C

Connection

Material: 316L Stainless Steel welded to case

Low back mount (LBM) 1/4" BSPT

Bourdon Tube

Material: 316L Stainless Steel

30" Hg to 800 psi by C-type

Movement

Stainless steel

Dial

White painted aluminium

Pointer

Micro Adjustable

Case

304 stainless steel with polished twist lock ring, with panel mount clamp

Ring

Bayonet SST ring with front flange

Window

Tempered glass, sealed to case with gasket suitable for silicone



Ordering Information

Part No	Description	Size
9095	0-1000 kPa/psi	63mm
PGSS1000	0-1000 kPa / 0-145 psi	100mm
PGSS1600	0-1600 kPa / 0-230 psi	100mm

NB: Order options - Silicon fill





Accessories

Filter Standard Sensing Assemblies

Sensing Assembly Kit

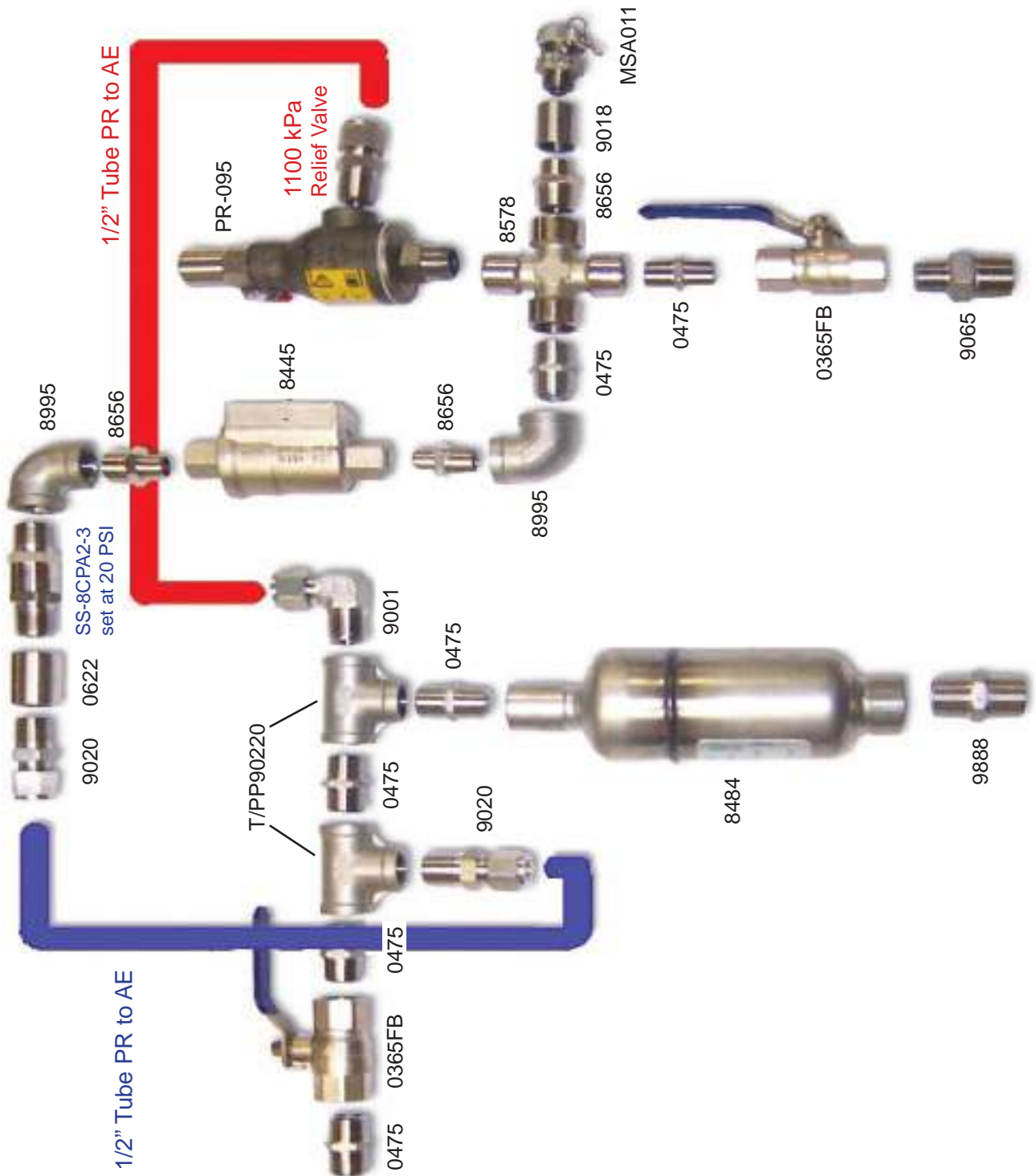

Filter Standard Sensing Assemblies

Ordering Information (Dispenser Assembly Kit - RH Operation)

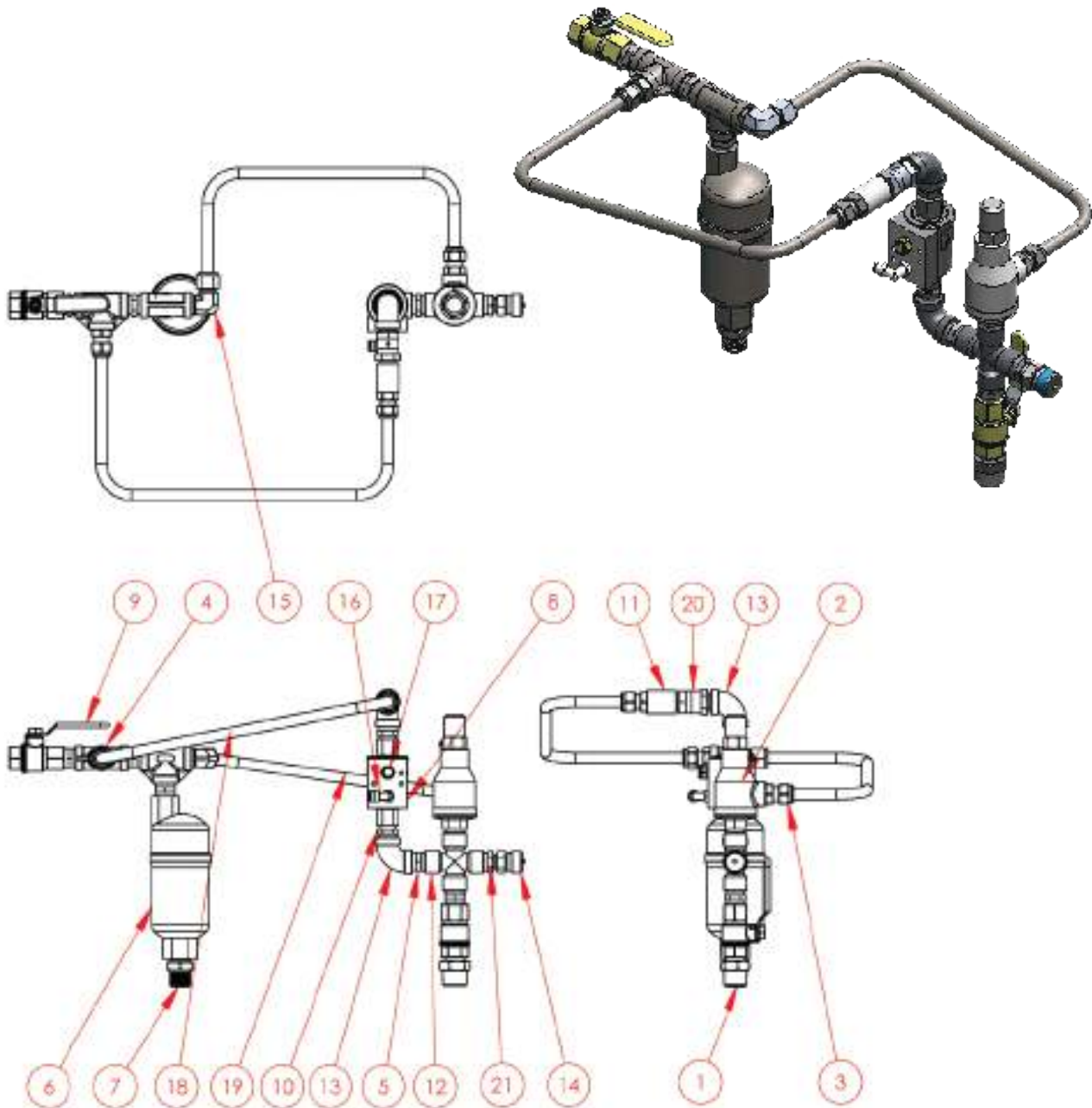

NOTES:

1. Apply Loctite 243 Threadlocker to all threads on assembly.
2. Ensure that the Axial Valve (Item 10) is mounted in a vertical orientation as shown.
3. Set non return valve (Item 20) is set and engraved @ 20 P.S.I
4. Certificate Test completed.



Filter Standard Sensing Assemblies

Ordering Information (Dispenser Assembly Kit - RH Operation)

Dispenser Sensing RH 5000-03-00			
Item No	Part No	Description	Qty
1	9065	3/4"BSPx1/2" BSP RED. NIPPLE SS	1
2	PR-095	1/2" BSP CERTIFIED RELIEF VALVE SS	1
3	9020	MALE ADAPTOR 1/2"BSP x 1/2" TUBE	3
4	T/PP90220	TEE - 1/2"BSP SS	2
5	0475	1/2" S/S HEX NIPPLE	5
6	8484	AIR ELIMINATOR	1
7	9888	NIPPLE 3/4"BSP SS	1
8	8445	3/8" AXIAL VALVE	1
9	0365FB	1/2" SS BALL VALVE FULL BORE	2
10	8656	1/2" X 3/8" REDUCING NIPPLE	2
11	0622	1/2" BSP SOCKET 304 SS	1
12	8578	1/2"BSP CROSS	1
13	8995	ELBOW F&F 1/2"BSP SS	2
14	MAS011	SAMPLING VALVE	1
15	9001	1/2" BSP x 1/2" TUBE SS ELBOW	1
16	8521	ELBOW FITTING 1/8"-6MM PUSH IN TUBE	1
17	2278V	1/8" AIR SILENCER	1
18	5000-03-01	TUBING FOR AXIAL VALVE TO TEE	1
19	5000-03-02	TUBING FOR PUMP RELIEF TO AE	1
20	SS-8CPA2-3	1/2"BSP NON RETURN VALVE 25 PSI	1
21	9994	BUSH RED 1/2"BSP x 3/8" BSP St.	1

Filter Standard Sensing Assemblies

Ordering Information (Refueller Assembly Kit)

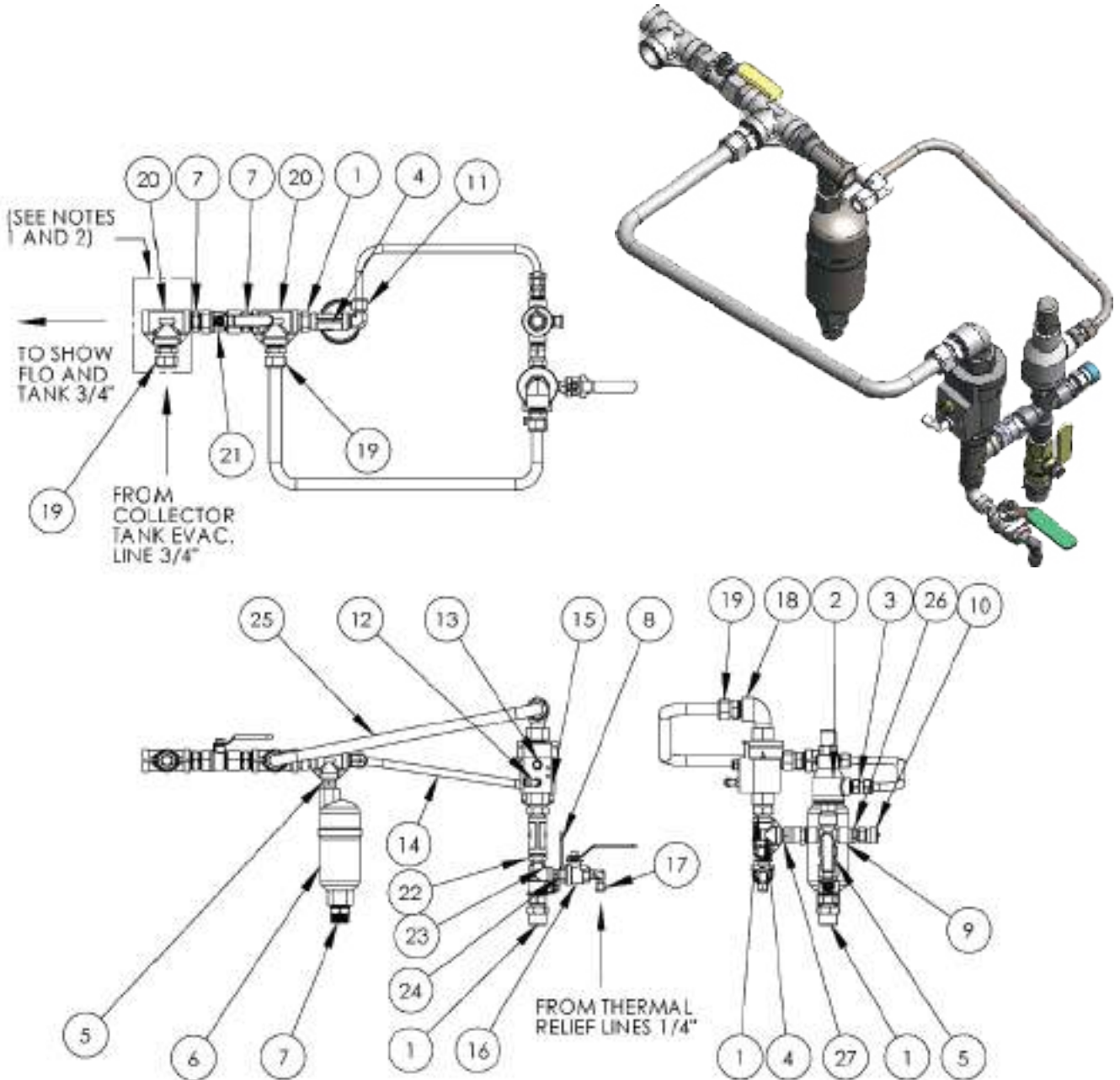

NOTES:

1. Assembly depicts for Collector Tank Evacuation by Pneumatic Diaphragm Pump.
2. Items indicated are not used when Collector Tank is evacuated by education.
3. Apply Loctite 243 Threadlocker to all threads on assembly.
4. Ensure that the Axial Valve (Item 10) is mounted in a vertical orientation as shown.
5. Ensure correct setting of Check Valve 8852 or between 14-22 PSI.

Filter Standard Sensing Assemblies

Ordering Information (Refueller Assembly Kit)

Refueller Sensing 5000-03-04			
Item No	Part No	Description	Qty
1	9065	3/4"BSPx1/2" BSP RED. NIPPLE SS	3
2	PR-095	1/2" BSP CERTIFIED RELIEF VALVE SS	1
3	9020	MALE ADAPTOR 1/2"BSP x 1/2" TUBE	1
4	T/PP90220	TEE - 1/2"BSP SS	2
5	0475	1/2" S/S HEX NIPPLE	2
6	8484	AIR ELIMINATOR	1
7	9888	NIPPLE 3/4"BSP SS	3
8	0365FB	1/2" SS BALL VALVE FULL BORE	1
9	8578	1/2"BSP CROSS	1
10	MAS011	SAMPLING VALVE	1
11	9001	1/2" BSP x 1/2" TUBE SS ELBOW	1
12	8521	ELBOW FITTING 1/8"-6MM PUSH IN TUBE	1
13	2278V	1/8" AIR SILENCER	1
14	5000-03-02	TUBING FOR PUMP RELIEF TO AE	1
15	8509	3/4" AXIAL VALVE N/O	1
16	8498	1/4" VALL VALVE SS	1
17	9025	1/4" BSPx 1/4" TUBE COMP ELBOW SS	1
18	8993	ELBOW S/S BSP M&F 3/4"	1
19	9024	3/4"BSP x 3/4" TUBE SS STRAIGHT TUBE FITTING	3
20	9823-20	TEE EQUAL 3/4" BSP SS	2
21	0367	3/4" BALL VALVE	1
22	9039	1/2"x1/4" Reducing Bush SS	1
23	9014	1/4" M-F BSP ELBOW	1
24	8866	1/4"BSP HEX NIPPLE SS	1
25	5000-03-05	TUBING FOR AXIAL VALVE TO TEE - REFUELLER	1
26	9994	BUSH RED 1/2"BSP x 3/8" BSP SS (9994)	1
27	SS-8CPA2-3	1/2"BSP NON RETURN VALVE 25 PSI	1

FACET Filtration

Liquip are an authorised distributor of Facet Filtration products. FACET is a global leader in aviation fuel filtration with more than 75 years of industry experience. Over this time, Facet have been on the forefront of aviation fueling for commercial and military aircraft.

FACET manufactures and markets filter housings, filter cartridges and complete filtration systems for hydrocarbon filtration and separation.

Liquip can design and manufacture filter vessel using Facet elements to ASME or Australia standards. The elements used in our vessel are qualified to the latest Energy Institute (EI) Standards for Aviation Fuel Handling. This means you can rely on our products to help you maintain clean, contaminate-free dry fuel. Our team of experts will ensure that you meet the most stringent performance and reliability requirements.



FACET Filtration - Aviation Filter Cartridges

Key Facet Elements offered

CAA Coalescer Series - Qualified to 6th Edition of EI 1581, Category C

This standard line of high flow coalescer cartridges removes ultra-fine solids and enhances separation of water from aviation fuel.

- Maximum water coalescence
- Withstand in excess of 75 psi (5.25 kg/cm²) differential pressure
- Designed to fit Facet HCS & VCS housings



CM Coalescer Series - EI 1581 6th EDITION CATEGORY C

This line of high flow coalescer cartridges removes ultra-fine solids and enhances separation of water from aviation fuel.

- Qualified to 6th Edition of EI 1581, Category M
- Multi-layered media for increased solids holding capacity
- Maximum water coalescence
- Withstand in excess of 75 psi (5.25 kg/cm²) differential pressure
- Designed to fit Facet HCS & VCS housings



SS Aviation Separator Coalescer Series - (EI 1581 6th EDITION CATEGORY C)

The SS-5 Series Synthetic and ST-5 Series Teflon® separator cartridges are cleanable and reusable. They come in a variety of dimensional and end cap configurations. Facet's SS-5 Series Synthetic separator cartridges feature a specially developed treated hydrophobic media.

- Cleanable and reusable
- Superior water barrier
- Recommended maximum operating temperature: 240°F (115oC)
- pH range from 5 to 9
- Flow direction: Outside to in



FG Series - 2" Aviation Monitors (Qualified to 7th Edition of EI 1583)

The Facet 2" (51 mm.) nominal outside diameter FG Series Fuel-Gard® monitor cartridges perform three jobs—they absorb free and emulsified water, remove ultra-fine solids and shut down system flow when hit with a localized slug of water, giving you clean, dry fuel.

- New conductive end caps with anti-static properties
- Structurally withstands a minimum of 174 psi (12 kg/cm²)
- Designed to fit Facet HFG & FGH 2" monitor housings



FG Series - 6" Aviation Monitors (Qualified to 7th Edition of EI 1583)

Facet's 6" nominal outside diameter FG Series Fuel-Gard® monitor cartridges perform three jobs to give you clean, dry fuel: absorbing free and emulsified water, removing ultra-fine solids and shutting down system flow when hit with a localized slug of water.

- Structurally withstands a minimum of 175 psi (1,200 kPa)
- Not adversely affected by exposure to temperatures varying from -40°C to 71°C.
- Works in the presence of surfactants and fuel additives but not those fuel containing anti-icing additive



FACET Small Filter Housings - VF-21 and VF-22 SERIES

Facet Filter Housing VF-22SB-PG

Eliminate the need for other water defense devices and receive maximum water removal, solids holding capacity and shutdown protection to assure clean, dry fuel delivery while meeting the effluent fuel requirements of the latest Energy Institute (EI) specifications.

Economical, compact housings for superior inline filtration protection when used with Facet's standard 21 or 22 Series filter cartridges to remove solids from aviation fuels. Both the exteriors and interiors of the Facet 21 and 22 Series filter housings carbon steel bodies are epoxy coated to protect against corrosion. These sturdy, single cartridge housings are easy to maintain and require only 2" (51 mm) base clearance for cartridge change out.



Key Features

- Sturdy single cartridge housing
- Carbon steel body
- Aluminium head
- Epoxy coated internally and externally
- Swing bolt quick open closure
- Vent and drain connections with brass petcocks provided
- 1.5" (38mm) NPT inlet and outlet connections
- Design pressure: 150 psi (10.5 kg/cm²)
- Recommended maximum operating temperature: 240°F
- Maximum differential pressure: 75 psi
- pH range from 5 to 9
- Flow direction: Outside to in

Associated Cartridges

- Model FG-0-609 series
- Model FG-0-612 series

ILS400 In Line Suction Strainer

ILS400 is a lightweight, inexpensive aluminium suction line strainer for larger pumps such as those fitted to large vehicles and prime movers for bulk industrial deliveries. It suits 76mm and 102mm diameter flow.

ILS400 in line suction strainer protects down stream equipment such as meters and pumps from debris and foreign objects. Strainer basket can only be fitted for correct direction of flow. Drain bosses provided in body and lid to suit any mounting angle.

Technical Specifications

Materials of Construction:	All metal construction. Cast aluminium body & lid. Steel mesh with aluminium surround. Nitrile seal. Available to aviation standard on special order.
Technical Data:	Maximum vacuum to 90kPa Maximum working pressure to 700kPa
Weight:	4.7 kg
Mounting:	4" TTMA flanges Mount with arrow in correct flow direction
Associated Equipment:	LBV4 50 butterfly valve BF4-SG-40, BF4-SG-25, sight glasses
Dismantle:	Simply remove lid by unscrewing 2 off lid retaining nuts and remove basket



ILS400 In Line Suction Strainer

Ordering Information

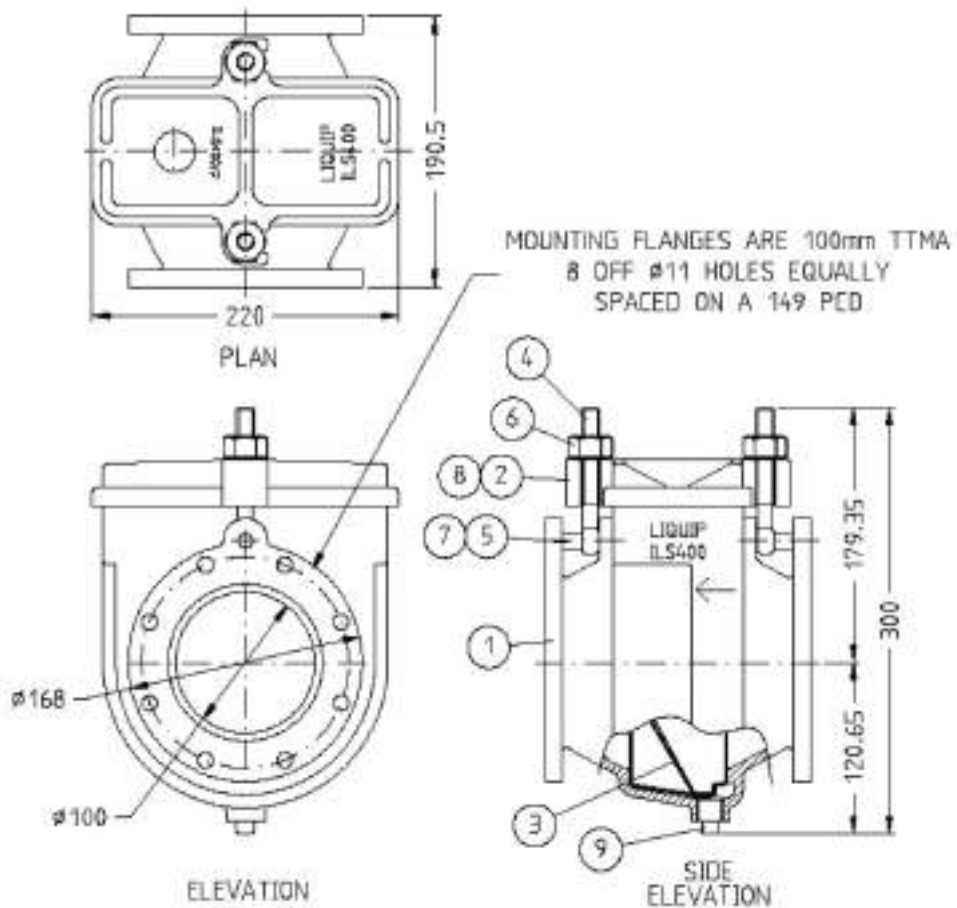

Item	Part No	Description	Qty	Material
1	ILS400-1	Body - Strainer	1	Aluminium
2	ILS400-2	Lid - Strainer	1	Aluminium
3	ILS400-3	Strainer Basket	1	AL & Zinc Plated
	ILS400-3-200P	Strainer Basket - 200 Mesh Size	1	AL & S/S
	ILS400-3-350P	Strainer Basket - 350 Mesh Size	1	AL & S/S
	ILS400-3-80P	Strainer Basket - 80 Mesh Size	1	AL & S/S
	ILS400-3-AV	Strainer Basket - 250 x 50 Mesh Size	1	AL & S/S
	ILS400-3-40S	Strainer Basket - 40 Mesh Size	1	AL & S/S
4	ILS400-4	Eyebolt	2	Z/P M/S
5	ILS400-5	Hinge Pin	2	Z/P M/S
6	ILS400-6	Nut	2	Brass
7	0194	O-Ring	2	Nitrile
8	2344	Seal Lid	1	Nitrile
9	70390	Plug - Square Head	1	Galv Stl

Basket Strainers

It is generally accepted that the presence of foreign matter in fluid handling systems is highly undesirable and can lead to the premature failure of critical high value items of equipment, such as pumps and meters. The installation of Basket Strainers is therefore highly recommended and widely practised in these systems.

The Basket Strainers offer the end user a very low pressure loss under high flow conditions and an extended operational life. They are supplied with a quick release lid as standard, and this feature allows the basket to be removed quickly with no special tools, hence minimising the downtime during basket cleaning. Basket removal is possible without the unit being fully drained. The lid is sealed with an O-Ring which gives the lowest possible clamping force with no gaskets required, and there is a side drain point to allow rapid drainage of the contents.



Features

- Cast Carbon Steel Body
- Rugged High Strength Design
- Stainless Steel High Capacity Low Pressure Loss Basket
- Choice of Basket Mesh Sizes
- PED Compliant
- Quick Release Lid, no special tools required for Basket removal
- Side Drain Point
- O-Ring Lid Seal, No Gaskets
- Optional Differential Pressure Tapping
- Optional Automatic Air Vent Valve

Specifications

Standard:	PED/97/23/EC
Design Pressure:	20.0 BarG (290 psig)
Test Pressure:	29.5 BarG (428 psig) (refer to flange tables for temperature limitations)
Flanges:	ANSI B16.5 150lb raised face
External Finish:	Red oxide primer. Other paint finishes on request
Internal Finish:	Clean and oiled as standard Abrasive blasted and painted with Copon EA4/EA9 white epoxy lining on request

Basket Strainers

Ordering Information

Item	Material
Strainer Body	ASTM A216 WCB
Strainer Cover	ASTM A516 Gr60/A216 WCB
Strainer Basket	Stainless Steel A316 40 mesh to 120 mesh
Cover O-Ring	Viton A
Vent Plug	ASTM A105N
Drain Plug	ASTM A105N
Strongback	ASTM A216 WCB
Screw Handle	ASTM A193 B7M/St. Steel Handle
Quick Release Pin	BS 970 080/M40 Zinc Plated
Linch Pin	Carbon Steel Zinc Plated

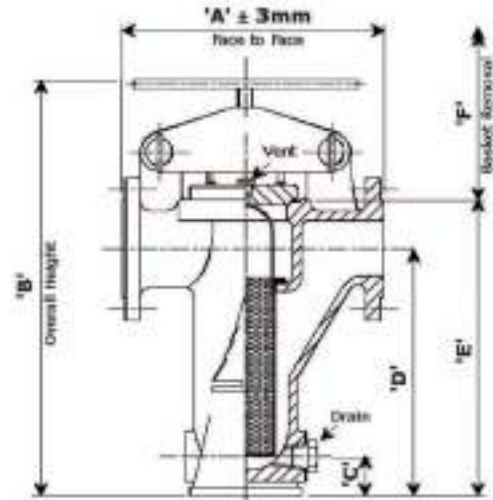

Part No	Size	A (mm)	B (mm)	C (mm)	D (mm)	E (mm)	F (mm)	Basket Area (sq. cm)	Vent ("NPT)	Drain ("NPT)	Nett Weight (kg)
6003073001	3"	365	570	40	342	410	375	652	3/8"	3/4"	47
6003074001	4"	445	695	47	426	505	450	1088	3/8"	1"	70
6003075001	6"	600	990	95	619	734	630	2151	1/2"	1.1/2"	167
6003083001	8"	715	1190	112	787	927	800	3973	1/2"	1.1/2"	310



Elaflex Rubber Expansion Joints

Electrically conductive flexible connections for pressure or vacuum

In fluid handling systems it is often necessary to make allowance for pipework expansion, vibration and slight misalignment. A multi-purpose solution to many of these problems is the Elaflex rubber expansion joint.

It compensates for stresses arising from these thermal variations or misalignment, substantially dampening vibration from associated plant such as pumps, compressors, etc. preventing the transmission of objectionable noises.

Rubber expansion joints have been proved in service for many years and are approved by a number of Authorities.

The TW YELLOW range is commonly used on aircraft refuelling units

Technical Specifications

Recommended for:	Hydro-carbon products with less than 50% aromatics.
Tube:	Seamless Nitrile NBR., oil resistant for temperatures up to + 100°C.
Cover:	Neoprene, electrical-conductive, oil resistant and weatherproof.
Flanges:	Forged aluminium.
Electrical Resistance:	Between 1k Ohms and 1Meg Ohms.
Max. Working Pressure:	10 Bar.
Test Pressure:	16 Bar



Elaflex Rubber Expansion Joints

Ordering Information

ERV-G Expansion Joints								
Length		Recommended Installation Length		Allowable Range of Movement in Service				
BL	Tolerance	EL minimum	EL maximum	L minimum	L maximum	max. lateral offset	DN mm	Angular rotation
130 mm	+5 mm -0 mm	120 mm	135 mm	100 mm	160 mm	±30 mm	25 - 50	±30°
150 mm		140 mm	155 mm	115 mm	180 mm	±30 mm	65 - 80	±25°
160 mm		145 mm	170 mm	125 mm	195 mm	±35 mm	100 - 150	±20°
175 mm		160 mm	185 mm	135 mm	210 mm	±35 mm	200 - 300	±10°
200 mm		180 mm	210 mm	160 mm	235 mm	±35 mm	350 - 600	±8°
250 mm	±6 mm	230 mm	260 mm	210 mm	285 mm	±35 mm	700 - 800	±6°
300 mm	±10 mm	280 mm	310 mm	260 mm	340 mm	±40 mm	900 - 1000	±5°

with 8-hole "TW" flanges DIN 28 461 of carbon steel, zinc plated

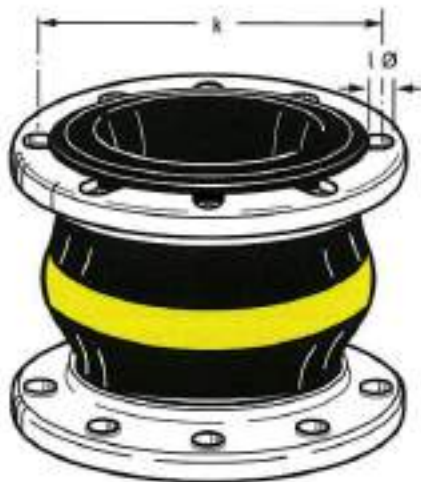

BL = 130 mm

Part No	DN mm	k mm	l Ø mm
ERV50	50	130	11,5
ERV65	65	130	11,5
ERV80	80	130	11,5
ERV100	100	150	14

PN 10

Swivels

SJF Flanged Swivels

The SJF Swivels are available in 4" size and provide rotational coupling of loading arm and hydrant cart components. SJF swivels are cast stainless steel. Sealing is enhanced by the purpose designed Viton primary face seal, and two Viton O-rings which isolate the bearing pack from product leaks.

In the unlikely event that the primary seal leaks, the product is contained by the O-ring before it can wash grease from the bearings causing them to fail in operation. Any leak is also immediately visible from a tell-tale weep hole. The greasing system incorporates the Liquip trade-mark pressure relief outlet to ensure correct lubrication, by ejecting old grease and particles that can cause wear. The 4" swivels have 4" TTMA flanges.



Ordering Information

Part No	Description	Material
SJF101L	SJF 4" Flanged Swivel with 4" TTMA flanges	Stainless Steel

VNS Swivels

The VNS-A4 is a 100mm (4") straight single-plane cast aluminium swivel with 4" TTMA flanged ends allowing 360° rotation. It may be used on any application where another plane of rotation is required.

For example it may be used on loading arms instead of the coupler spool to enable rotation of the API coupler. Liquip's grease relief system (grease nipple one side with relief valve mounted opposite for efficient removal of old grease and debris) extends the life of the swivel by ejecting old grease and wear particles. Dual O-Rings are for product seal and dust seal respectively.



Ordering Information

Part No	Description	Material
VNS-A4	4" Straight Single-plane Swivel with 4" TTMA flanged ends	Aluminium

Swivels

SJW Weld-On Swivels

SJW Swivels are available in 3” and 4” sizes and can be of Mild Steel or Stainless Steel. These swivels are used for fabrication of loading arms and pipework requiring up to 360° rotational joints. They are machined from Nitrided Steel with pre-prepared ends for welding directly to pipe or tube.

SJW Swivels are a most cost-effective way of achieving a rotating joint, for loading arms or other equipment requiring swivelling joints. Sealing is enhanced by the purpose designed Viton or Teflon primary seal, and two Viton o-rings which isolate the bearing pack from product leaks. In the unlikely event that the primary seal leaks, the product is contained by the O-Ring before it can wash grease from the bearings causing them to fail in operation. Any leak is also immediately visible from a tell-tale weep hole. The greasing system incorporates the Liquip trade-mark pressure relief outlet to ensure correct lubrication, by ejecting old grease and particles that can cause wear.



Ordering Information

Part No	Description	Material
SJW075MMVZ	SJW Weld-On 3” Swivel	Mild Steel
SJW100MMVZ	SJW Weld-On 4” Swivel	Mild Steel



Camlocks

The standard range of Camlocks are to NATO specification MIL-C-27487. Aluminium construction, all units confirm to Australian Code of Practice CP23.

Aviation Selective Couplings

The aim of these units is to ensure that all dedicated aviation road tankers fitted with selective couplings are compatible and can be loaded ONLY with aviation fuels, and that all aviation receiving points can ONLY accept aviation fuels from the dedicated road tankers.

The Liquip range of dedicated couplings provide product selectivity between Avgas and Jet Fuel and are available in the following configurations:

- Top and bottom loading
- Gantry loading valve
- Road tanker API valve
- Road tanker API to camlock adapter
- Female camlock hose end fittings
- Male camlock receipt point fittings

The standard range of Camlocks are to NATO specification MIL-C-27487. Aluminium construction, all units confirm to Australian Code of Practice CP23.

Notches and pins are used to dedicate these couplings for use with Aviation Gasoline or Aviation Turbine Fuel, thus preventing the wrong product being loaded into the wrong tank.

Ordering Information

Contact the Liquip Sales Department for assistance in determining which of the numerous models, sizes and options available will best suit your needs.



Static Reels

LSR100 Lockable Static Earthing Reel

Static reels are used to bond two pieces of equipment to allow static charge to be safely equalised. Static reels are typically used when product is transferred from one tank to another e.g. when pumping between a tanker and storage tank or when fuelling aircraft.

Liquip offers the LSR100, which has been developed to provide users with a safe and reliable static earthing reel that when locked won't inadvertently unwind while a vehicle is moving.

Technical Specifications

- Nominal reel resistance is 5 ohms
- Meets AS 2809:2 – Maximum end-to-end resistance of 10 ohms.
- Carbon brush runs in sealed section to eliminate dirt and corrosion.
- Shaft has grease reservoir for all-of-life lubrication.



SR202 Static Earthing Reel

Static reels are used to bond two pieces of equipment to allow static charge to be safely equalised. Static reels are typically used when product is transferred from one tank to another e.g. when pumping between a tanker and storage tank or when fuelling aircraft.

Liquip offers the SR202, which has been developed to provide users with a safe and reliable static earthing reel.

The SR202 has a large drum so that it can be wound quickly and is fitted with a cable guide.

Technical Specifications

- Maximum end-to-end resistance 2 ohms.
- Carbon brush runs in sealed section to eliminate dirt and corrosion.
- Shaft has grease reservoir for all-of-life lubrication.
- Can hold up to a max of 76m standard PVC coated wire (4mm diameter)



Static Reels

Ordering Information

Static Reel SR Series	
Part No	Description
LSR100	Lockable static reel complete with 30m cable and bonding clip.
SR202	Large diameter static reel comes with cable guide, manual operation
LR203	Large diameter Lanyard reel c/w 15m ORANGE cable & dog-clip

Static Cable and Clamps

Liquip have a large range of static reel accessories available.



EKG1200



KK100



9170

Static Clamps	
Part No	Description
EKG1200	Static cable & aircraft clamp/clip - Solid heavy duty brass clamp complete with 1.2m of cable
KK100	Static clamp - Heavy duty solid brass clamp
9170	Static clamp - Standard plated steel with teeth jaws
GTP-1101	Static clamp - Aluminium alloy clip to MIL-C-83413/7, jaw gap 2mm fully closed
GTP-1097S-1	Aircraft grounding pin - Stainless steel

Static Cables	
Part No	Description
SR100-18	Static cable 2mm - Galvanised wire 6x7 strand, yellow PVC coated (1,00m roll or cut lengths)
9457	Static cable - Stainless steel wire, reflective orange PVC coated (300m roll or cut lengths)

Static Reels

LSR100 Installation Guide

Good electrical conductivity at the mounting bracket is essential to the performance of the static reel.

The mounting bracket itself must be chosen for its continuity with the vehicle chassis and both sides of the mounting bracket must provide a clean, smooth, bare metal surface of at least 15mm radius from the centre of the 13mm diameter hole. Ensure the inner nut is tightened securely on the shaft and fasten the assembly with the outer nut and spring washer on the other side of the mounting bracket.

For LSR100 fitted with the optional spacer and cable guide, fit onto the shaft first and tighten with the inner nut. The entire reel is then secured to the mounting bracket by the spring washer & outer nut on the other side of the bracket.

Further earthing continuity may be obtained by fitting a ring terminal and wire (not supplied) between the fixed nut and the mounting bracket and running it to a second earthing location on the chassis. Using a multimeter, confirm resistance from clamp to chassis is less than 10Ω.

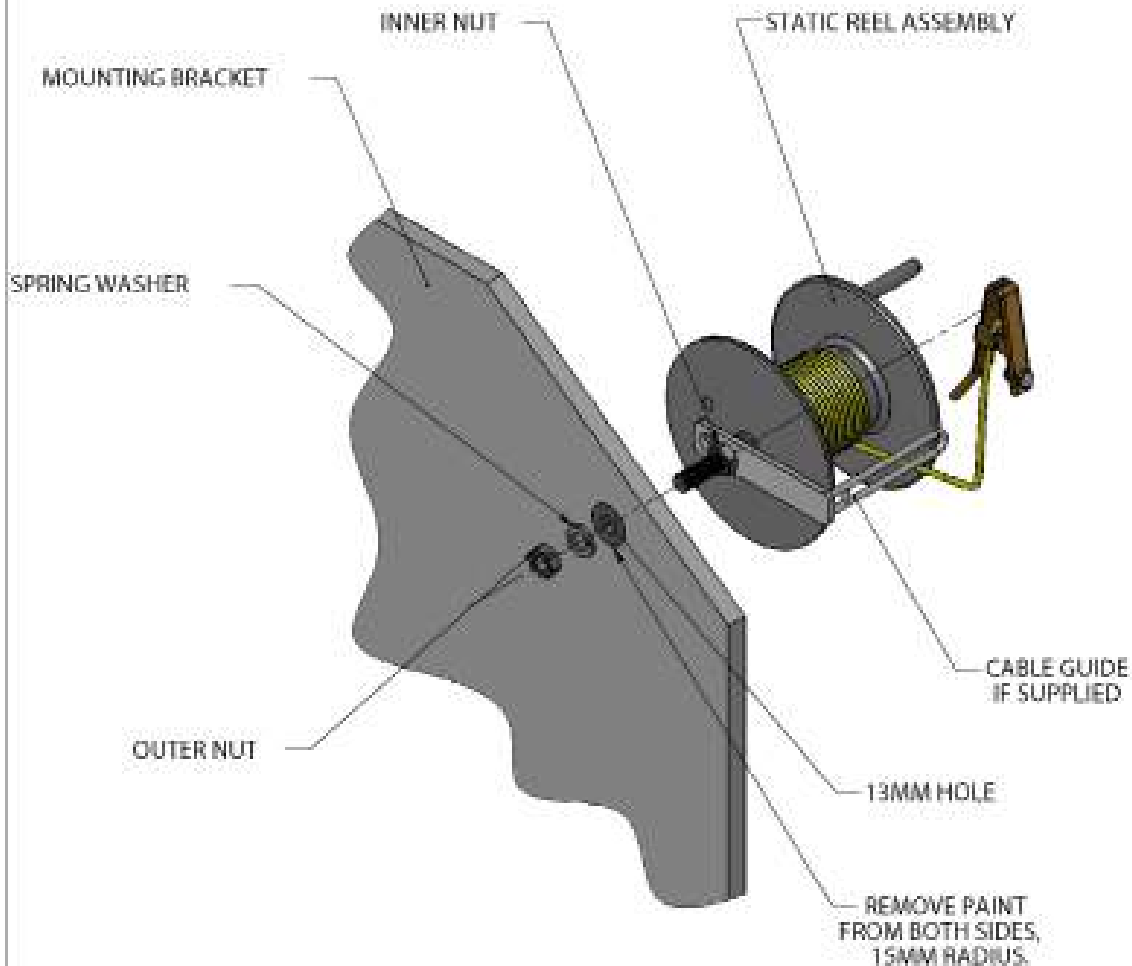

METERS - VALVES - VENTS - MANHOLES - HOSE REELS - OVERFILL PROTECTION - LOADING ARMS - ELECTRONIC DIPSTICKS



LIQUIP
P.O. Box 7049
Wetherill Park BC, 2164
Sydney NSW Australia
Email: liquip@liquip.com
Phone: +61 2 9725 9000
Fax: +61 2 9725 1252

DISTRIBUTORS
See website for Liquip branches and Distributors
www.liquip.com

L110714

Sheet 1 of 1
Issue: A

Aljac Continuity Tester

Safe, reliable and cost effective loading of fuel

The Aljac Continuity Tester (ACT) is a foolproof Go/No Go device which can be used by non-skilled personnel, and it is controlled by a microprocessor which offers significant operational advantages. It self checks calibration and available battery power and only then allows the test to proceed. The ACT uses a single dual colour light emitting diode (LED) to indicate the condition of the bonding system under test, which makes the results very simple to interpret. The default set point is 25 Ohms which is in accordance with the JIG Guidelines for aviation fuel systems, but alternative set points can be specified at the time of order placement. In addition, throughout the test, a two figure digital display tells the operator the actual system resistance (in Ohms).

The ACT housing is ergonomically designed to be comfortably held in the hand and is moulded from impact resistant Polyamide, so it is lightweight, robust, and is highly portable. The ACT incorporates a sealed, non rechargeable, high capacity battery which gives it an extended operational life, but the battery life is further enhanced by a number of power saving features. The ACT does not have a constant power usage, it checks the resistance 200 times per second. Also, the microprocessor automatically switches off the ACT after a time out period at any stage of the operation, even if the clips are left connected or touching at the end of the test.

The ACT can be supplied with a calibration certificate if required, but in any event it self checks calibration before every test. The ACT incorporates a current limitation feature and is safe for use in hazardous areas, unlike many other devices which are currently in use. We can provide a Stowage Bracket which can be used to neatly stow the ACT when not in use, or can hold the ACT securely during testing.



Technical Specifications

- Type: Go-No Go Continuity Tester
- Set Point: 25 Ohms (default). Option 1 to 40 Ohms
- Test Frequency: 200 tests per second
- Display Update: Every 100 tests (0.5 seconds)
- LED: Dual colour high intensity (Red/Green)
- Display: Two digit 7 segment LCD, 12mm character height. Selectable on or off
- Housing: High visibility orange impact resistant PA6 Polyamide
- Battery: Lithium Thionyl Chloride 3.6V
- Microprocessor: Atmel AVR EXMEGA 16A 4U
- Flying Leads: 2 x 0.5 metres long, with plugs/clips

Ordering Information

Part No	Description
0100400180	Continuity Tester
0100400181	Stowage Bracket

Net Weight: 180 grams

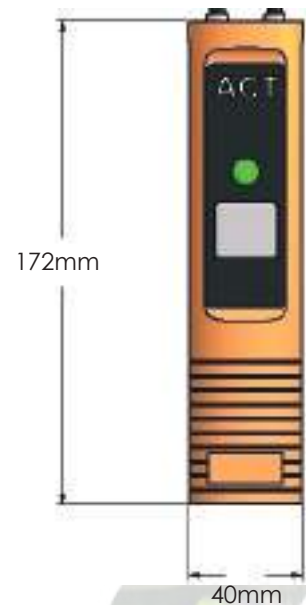

Smartwire PLC

With Liquip SMARTWIRE system the options are virtually unlimited.

The SMARTWIRE system is a 2-wire programmable control system designed to simplify implementation and installation. The system consists of input and output modules, a power filter and an interface board.

With the SMARTWIRE system a majority of the operational functions of fuelling aircraft are transformed to electronic form. The system is extremely flexible, offering easy adaptation in the field, if required, without costly modifications.

The SMARTWIRE PLC ensures that all fuelling operations cannot be overridden by an operator and it features a time-out which ensures the “deadman” is present in the operators hand at all times. The same PLC also controls all interlock functions for nozzle stowage, deck lowering, P.T.O. and all bottom load gates.

Liquip individually program each PLC to suit customer requirements.



Ordering Information

Part No	Description
	Smartwire PLC



Power Conditioner

This LIQUIP DCC100 is an electronic Power Filter which conditions power to Electronic Meter Register systems (EMH*), Overfill systems (such as Diptronic® DIP200) etc on Liquip aviation Refuellers and Hydrant Dispensers (where fitted) to protect connected equipment from surges and voltage spikes generated by vehicle operation. One DCC100 is required for each unit (piece of equipment / component) being protected.

Technical Specifications

Materials of Construction:	Heatshrink, plastic, metal.
Mounting:	The DCC100 is not designed to be exposed to dirt or moisture. It must be either mounted in the cab area, typically in the fuse box, or inside a junction box of IP rating 66 minimum (Liquip JBL100 or similar) <ul style="list-style-type: none"> • Ensure cable glands are rated for a minimum IP66. • Wire as per wiring diagram attached. • Ensure IP66 rated blanking plugs are used in any unused holes in junction box.
Weight:	0.1 kg (without junction box)
Input Voltage:	9V-36V DC
Output Voltage:	12V DC
Maximum Load:	Total 1.67A Continuous
Voltage Spike Protection:	Protect up to 50V/100ms spike
Output Voltage Noise:	Less than 0.1V
Recommended Fuse Rating:	3.15A slow blow
Cable Size:	0.2– 2.5mm ² , strip length 6mm
Ingress Protection:	IP20
Dimensions:	55W x 65L x 25H (mm)
Associated Equipment:	DIP200, DIP240, EMH5xx, EMH6xx, MPP102, PPM300 Series, COP Series JBL100 Junction box IP66 with 3 x M20 holes

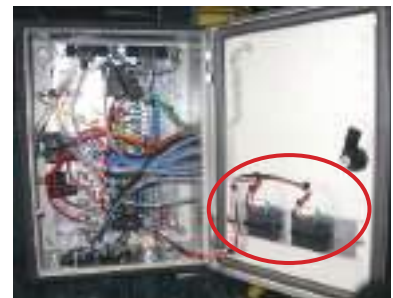

Power Conditioner

DCC100 Wiring Diagram

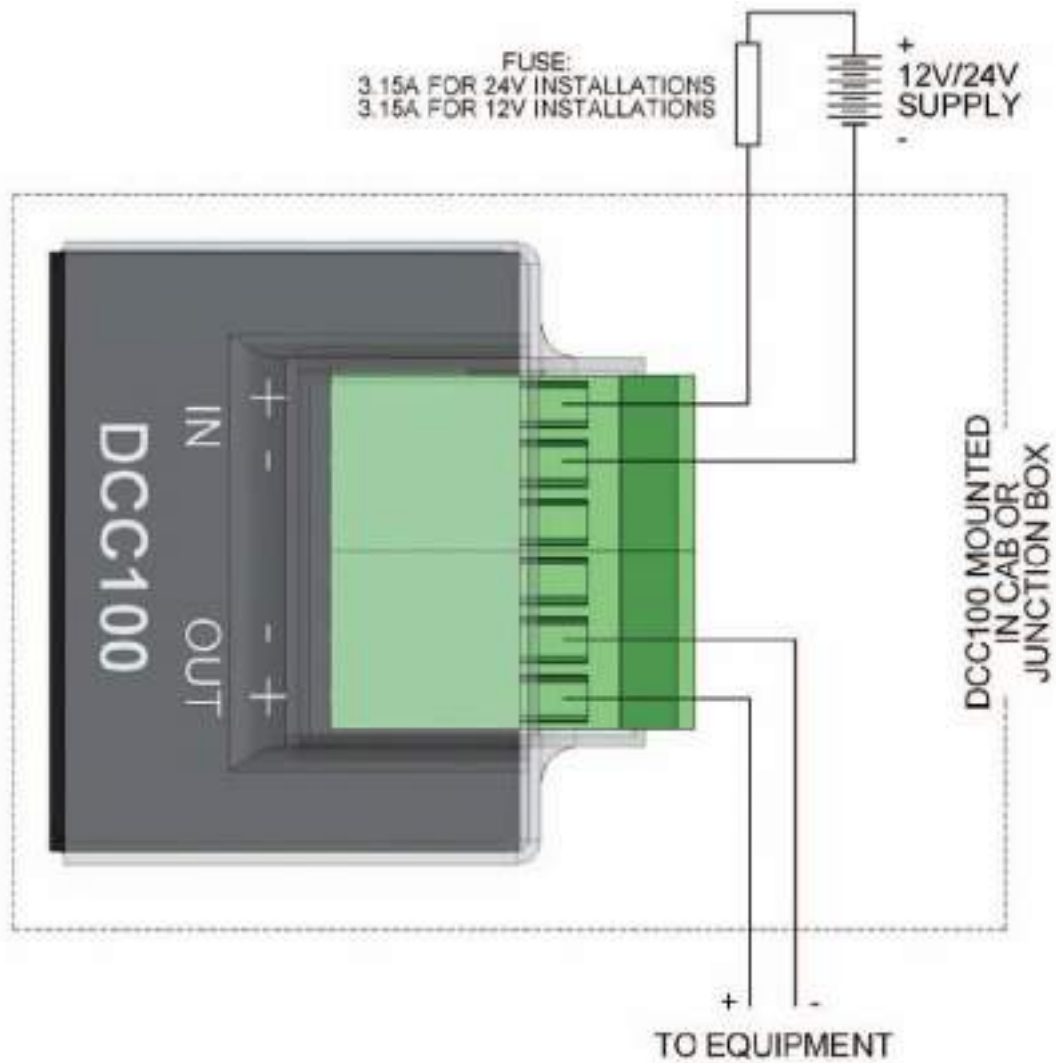

NOTE:

This is a general wiring diagram ONLY.
Any wiring instructions for specific equipment supersede this diagram.

Ordering Information

Part No	Description
DCC100	12 VDC Output Power Conditioner



Deadman Assemblies

Excellent operator comfort

Deadman system is a safety device with intrinsically safe wiring that confirms a critical operation is constantly supervised. Liquip deadman handles are compact, durable and designed for maximum operator comfort. They contain a sealed micro-switch (enclosed in the handle) with a cable connection. The handles require low operating force and are wear resistant. They are designed for the aviation environment and easy to assemble/disassemble. The bright orange “curly” lead is 3.4 metres (14’) long and will stretch to 18 metres. Longer cables are available on special order.

Ordering Information

Deadman Assemblies	
Order No	Description
8422	COMPLETE Assembly 1 (ALUMINIUM Deadman complete with cable / curly cord)
GTP-8392-Z-50	COMPLETE Assembly 2 (PLASTIC Deadman complete with cable / curly cord)

Deadman Spare Parts		
Item No	Part No	Description
1	DMH100	Aluminium Deadman - Handle ONLY
2	8693	Cable / Lead (curly cord), orange, 3.4m.
3	9097	Cable plug Male sealed 2W
N/A	DMH102	DEADMAN HANDLE AL WITH CABLE C/W MED Cable



Decals & Signage

Liquip carry an extensive range of fuel handling decals and labels. All decals are printed on top quality decal stock for long life in all conditions. Engraved operational signage is laser cut.

AVGAS & JET A-1

Pipeline markers are available in 57mm & 100mm. Other variations are also available to suit Oil Company requirements.

CLASS SIGNS

Type 1 to 9. Available in metal or adhesive vinyl.



Ordering Information

Part No	Description
2270	Class 3 sign
2272	Holders for class signs in pressed steel (zinc plated)
9906	No Smoking Sticker (220 x 220mm)



Spill Management Products

Contain any spill by having everything you need for fast, efficient response on-hand. In areas where spills are likely to occur, the Liquip range of Spill Kits takes the guesswork out of clean-up. Refills are available for all kits.

Custom Kits

Liquip have spill kits for a wide variety of applications. If you have a special requirement, Liquip can design a kit to fit your needs and budget. "SELECT" absorbs oil / petroleum products while repelling water.

Also Available: Large Drum kits, Booms (various sizes), Folded Rolls, Absorbent Mats

Zippered Truck Kit (15" X 18" X 6")

CONTENTS	SELECT
Socks	(3) 3" x 48"
Sheets	(30) 17" x 19"
Absorbs	28.4 litres

Duffel Bag Kit (29" X 13" X 12")

CONTENTS	SELECT
Socks	(3) 3" x 96"
Large Sheets	(25) 17" x 19"
Pillows	(2) 15" x 25"
Disposable gloves	1 pair
Disposable bags	2
Absorbs	64.35 litres



Spill Containers

These fully sealed Spill Containers are lightweight, strong and resistant to most chemicals. Spill Containers feature: Quick release lid, Meshed floor, Drain point ball valve, PVC construction

Ordering Information

Part No	Description
JBFA65	Spill Kit Container
8790	Zippered Truck Kit
8834	Duffel Bag Kit
CEP-P100	17" x 19" x 3/8" Sheets
8835	Sock 3" x 48"
9107	Disposal Bag



Platform Ladders

The Hills / Bailey range of aluminium platform ladders conform to Australian and New Zealand Standard 1892 and have an industrial load rate of 140kg.

Available with “Treadsafe” platform and optional safety-advice decal.

Features

- Industrial Duty Rated. Designed for use on industrial work sites where greater strength and safety is required
- Heavy Duty, 150kg Load Rating
- Strong, aluminium construction
- Fully welded front and rear frames for strength and durability
- Wide, aluminium anti-slip platform (490x400mm) for a secure work area
- 900mm handrail height from platform
- Anti-slip rubber feet for added safety and stability
- Made to Australian and New Zealand Standards AS/NZS 1892.1
- Available - optional retractable Castors/Wheels Kits
- Australian Made & Owned



Ordering Information

Part No	Description
FS13315	0.6 (2") HD Platform Step 2
T/PP93611	0.9m (3") HD Platform Step 3
FS13311	1.1m (4") HD Platform Step 4
FS13314	1.4m (5") HD Platform Step 5
FS13316	1.7m (6") HD Platform Step 6
FS10718	2.0m (7") HD Platform Step 7
FS10719	2.3m (8") HD Platform Step 8
FS22971	Castor/Wheel Kit (Fits 2-6" Plat)
FS22972	Castor/Wheel Kit (Fits 7-8" Plat)

All product dimensions indicated are nominal.



Wing Mats

These wing mats are designed to protect the aircraft wing from damage by the hose and nozzle during overwing refuelling. They are manufactured from thick durable Urethane, which is fuel and ultraviolet light resistant, weatherproof, non-marking and non-abrasive. The mats are also heavy enough so that they will not become displaced in windy conditions. They are available in a range of colours but our normal stock colour is high visibility Orange. However, in order to reduce risk of supplying the incorrect fuel grade (mis-fuelling), we also stock Red (for AVGAS) and Black (for Jet A1). Using the appropriate colour for the fuel being dispensed causes the refuelling operator to think about the fuel grade required, and any third parties (including the pilot) could also be more aware of the grade of fuel being delivered.

Ordering Information



Size: 460 x 610mm, opening diameter 127mm

Part No	Colour
56AFP-1824	Hi-Vis Orange
56AFP-1824B	Black
56AFP-1824R	Red



Size: 460 x 920mm, opening diameter 127mm

Part No	Colour
56AFP-1836	Hi-Vis Orange
56AFP-1836B	Black
56AFP-1836R	Red

Overwing Refuelling Tags - Mis-Fuelling Prevention

When refuelling light aircraft, the pilot is often not present which increases the risk of supplying the incorrect grade of fuel (mis-fuelling). In order to reduce this risk, and at the request of one of the major fuel suppliers, we have developed a Refuelling Tag. After completion of each refuelling, the appropriate tag is filled in by the refuelling operator and tied to the controls of the aircraft. When the pilot return to the aircraft, it is then clear to him which grade of fuel has been delivered before he attempts to move the aircraft.

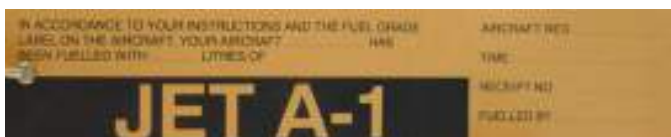

Part No	Description
0906000133	Jet A1 Refuelling Tag (Pack of 50)



Part No	Description
0906000134	AVGAS Refuelling Tag (Pack of 50)

Stainless Steel Buckets

Stainless steel buckets complete with carry handle, pourer, static lead and clamp.

Ordering Information

Part No	Description
T/PP95483	Stainless steel bucket



Fire Extinguisher Holder

These new lightweight fire extinguisher holders are a strong, durable design. The flat back ensures easy installation and they can be mounted on either truck or trailer. An internal tension strap helps secure the extinguisher and minimise any movement inside the holder. Will accept extinguishers 600mm in height.

Ordering Information

Part No	Description
JBFR75	Fire Extinguisher Holder



 mm	 mm	 mm	 mm
750	300	300	600+

Stainless Steel Safety Lock Wire

Safety wire or lockwire is a type of lock mechanism that prevents fasteners from loosening due to vibration and other forces. The presence of safety wiring also indicates that the fasteners have been properly tightened.

Ordering Information

Part No	Description
GTP-1924	.032" Stainless Steel Safety Lock Wire



Water Finding Paste

Water Finding Paste is a water detection system used to aid in the detection of water within fuel supplies. Water Finding Paste is normally used in the petroleum industry to monitor and detect moisture levels in various fuel types.

Ordering Information

Part No	Description
On request	Jars or tube of Water Finder Paste available



Fuel Finding (Ullage) Paste

Kolor Kut Fuel Finding (Ullage) paste is light pink in colour and turns deep red upon contact with most hydrocarbon fuels. It gives a clear level reading on the dip rod or tape, even when evaporation at the interface would normally cause distortion of the reading.

Ordering Information

Part No	Description
M056	Kolor Kut 62g Tub Fuel (Ullage) Paste



Density Calculator

The Density Calculator converts density reading taken with a hydrometer to corrected density at 15°C. It separates scales for 3 different types of fuel.

Ordering Information

Part No	Description
GTP-2727EF	Density Calculator





LIQUIP GLOBAL PRESENCE

To view the full range of Liquip's Aviation Products

Please visit www.liquip.com

or contact us at

Liquip Head Office

13 Hume Road, Smithfield
Sydney NSW Australia 2164
Tel: +61 (2) 9725 9000
orders@liquip.com

Retail Fueling

Components and products to protect the environment and the consumer at retail fueling sites for conventional and alternative fuels.

Dispensing & Automation Solutions

Manufacturing a complete range of fuel dispensers, pumps and automation systems for the global retail fueling market.

Electronic Systems

Innovative electronic tank gauges and fuel control systems to ensure customers know how much fuel they have and where it is going. Also, Automated Vehicle Wash Systems.

Chemical & Industrial

Safe and efficient loading and unloading of critical hazardous chemicals: loading arms, swivel joints, sight flow indicators, quick and dry disconnect couplers, and safety breakaways.

Transportation

Components and systems for use on Tank Trucks and Rail Tank Cars to ensure the safe handling, loading, transport and unloading of hazardous bulk products, including: petroleum, chemical and dry bulk cargo.