



total refuelling solutions

quality
performance
value for money



contents

fuelling components & spares

electrical & electronic
gauges, monitors, test & control equipment
hoses, connectors, valves & switches
vehicle accessories
new products



Lamp assembly – vapour-proof

Part No. DB26069-AI-BI-CI-GI-R

Description

DA25060 - Lens Adapter

Vapour-proof lamps, choice of lens colours Amber/blue/clear/green/red. Lens/lamp adaptor converts old-style base to accept new-style lens.

Available as component parts or complete units.



12-24V multitone sounder

Part No. FT-005214

Description

Audible sounder prompt for use with deadman warning scissor-lift movement, recovery tank full and vehicle reversing.



Current limiting relay 24v DC

Part No. DA1860

DA1860-PCB (24v PCB only)

DA1859 (12v)

DA1859-PCB (12v PCB only)

Description

These reliable relays limit the system current to intrinsically safe levels so that no sparking can occur if a wiring fault develops. The relay must only be used in systems where no energy storing is possible, preferably using hermetically-sealed proximity switches. Provides safe operation of interlocks in Deadman and interlock systems. Overload protection of switching current (limited to 2A, relay coil limited to 100mA). Resilient mounting enclosure.



Deadman handswitch

Part No. DAA11101

Description

'Release to close' handswitch to control the opening and closing of the secondary pressure control valves (in-line or pit coupler), enabling the operator to react quickly to any incident by terminating the fuel flow.

- Fuel-resistant switch housing
- Operating temperature range -40°C to +105°C
- Max voltage 100Vdc
- Enclosure protection to IP67
- Shock rating 100g.



Deadman handle cable, cable and plug

Part No. **DAA11115-1/-2/-3/-5**

Description

- Coiled as standard, complete with **FT-005238** male end plug to connect to **FT-005239**.
- Standard lengths: 3m, 10m, 14m, 18.25m
- 6m, 8m, 16m, 20m, 22m, 24m, 30m available to order.

DAA11117-1/-2/-3/-5

As above but without **FT-005238**
(male end plug)

DA1418 Suzie cable only, lengths as above.



Niphan socket and box conduit

Part No. **FT-005239** socket
FT-005237 20mm conduit

Description

Vehicle-mounted socket units to be used in conjunction with deadman timer and Suzie cables **DAA11115** when fitted with **FT-005238** male end plugs.



Electrical wing contactor

Part No. **DB23447 (300mm)**
DB26809 (300mm)

Description

Automatically disables the hydrant dispenser, platform lift when contact is made with the wing or any other solid object. Robust plastic body unit, aluminium antenna construction.

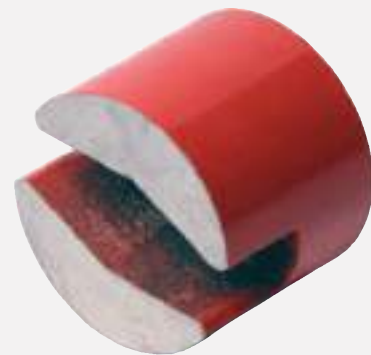

Magnet

Part No. **FT-005240**

Description

Switches the polarity of proximity switch **DB0860**.



Proximity switch

Part No. DB0860

Description

Proximity switch assembly consists of sensitive switching mechanism bonded within a moulded enclosure complete with aluminium lid and gasket. Used for actuation of vehicle brake interlocks. Features a robust moulded mounting case.



Reed switch

Part No. DAS11110

Description

Replacement reed switch for Deadman handswitch *DAA 11101*. Allows activation of hand switch unit when handle is depressed.



Deadman timer system

Part No. DBA10826

Application

The Fluid Transfer Deadman Timer System ensures the operator has effective control by demanding a positive input from the operator during refuelling operations. This is achieved by means of a timer circuit designed to time out every 1.5-2 minutes. Flow is stopped after this period unless the operator generates a reset signal by releasing and gripping the handswitch.

Dimensions

L 165mm W 135mm H 95mm

- 12-24v power supply
- Can be linked to optional vapour-proof lamp assembly to provide a visual prompt, *DB26069*.
- May also be linked to an optional sounder to provide audible prompt, *FT-005214*.



Replacement PCB board for Deadman timer system (*DB10826*)

Part No. DBA10826-PCB

Description

Replacement PCB for the Fluid Transfer Deadman Timer System. A straight swap-over ensures a quick and easy install while conforming to the latest JIG standards of requesting an input after 1 min 30 sec and shutting down at 2 minutes if no input signal is received.

Relates to deadman timer system (left).



Interlock monitor

Part No. DBA12630
DAM12616 – PCB only

Description

The Fluid Transfer interlock monitor incorporates 10 large high-intensity LEDs which inform the operator which interlocks are open. The interlock separates the interlock system into into 10 parallel circuits, each circuit electronically monitored. When the circuit is opened (equipment removed from stowage) the appropriate LED changes colour from green to red, informing the operator which interlocks are open and reducing the time taken to identify any incorrectly-stowed equipment.

Interlock checks can be performed during the normal refuelling operations, on an ad hoc basis or as part of the fuelling procedure. The unit ensures that the vehicle brakes are applied until all switches are closed (equipment correctly stowed), LEDs all green. The time needed to perform interlock checks is greatly reduced because several switches can be checked simultaneously.

The current in the interlock circuit is limited to intrinsically safe levels so that no sparking can occur if a wiring fault develops. The use of dual-colour LEDs eliminates the true state of a circuit being shown due to a failed LED lamp.



Emergency stop buttons

Part No. SK2777 / SK2779

Description

SK2777 for normally open applications
SK2779 for normally closed applications



Clip stowage assembly, left and right hand units

Part No. DC1678-1 (left hand)
DC1678-2 (right hand - depicted)

Description

Solid aluminium main body construction, complete with proximity switch and magnet used to ensure the correct stowage of the bonding reel. Left and right-hand vehicle mounting options available.



Rear light cluster

Part No. FT-005221
FT-005222

Description

Bespoke rear light clusters to suit individual vehicles. Available in 12v or 24v.



LED side marker light & chrome bezel

Part No. FT-005235
FT-005236

Description

Visual indicator to show when the PTO (power take off) unit is engaged and vehicle is in operation. Gives vehicle high visibility, enhancing safety to both operator and vehicle while out on the apron. Available in 12v or 24v.



Battery master switch, double pole

Part No. FT-005229 24v
FT-005231 12v

Description

Isolates the vehicle's electrical system from both the negative and positive battery terminals. Used with part *FT-005232* to allow the operator external control. Allows controlled power-down of microprocessor-based electrical systems. A compact and robust design requiring no routine maintenance. Conforms to ADR regulations and is ATEX approved.



External battery switch

Part No. FT-005232

Description

Compact design, weatherproof construction. Allows external operation of the battery master switch *FT-005229* and *FT-005231*.



Tacho/totaliser assembly

Part No. FT-005234

Description

Pump speed monitor with electronic display.



Electrical relays, flasher units and fuses

Part No. FT-005246 24v relay unit
 FT-005246 12v relay unit
 FT-005248 24v flasher unit
 FT-005486 12v flasher unit

Description

12v and 24v replacement electrical relays and flasher units for various applications. A complete range of 'blade' and standard 'glass tube' fuses in various ampere ratings supplied from stock.



Replacement bulbs

Part No. Various

Description

24 or 12-Volt replacement bulbs to suit most applications. Please call with your requirements.



Work lamp

Part No. FT-005241

Description

Together with the special honeycomb in the lens, the parabolic reflector allows homogeneous illumination of the close-range working space. This worklight can be used with both 12v and 24v vehicle electric systems, depending on the bulb voltage.



ATEX inspection lamp

Part No. FT-005242

Description

- ATEX approved for Zone 1 applications Ex II 2G Eex d (e) IIC T3/T4
- Temperature class to T4 depending on power rating
- Housing in die-cast aluminium or stainless steel
- For sightglass fittings from DN50
- Operating Voltage from 12V to 240V AC/DC
- Power depending on voltage up to 50W
- Secured on edge of flange by bracket or integral with flange using an upstand fitting
- Available with integral timer switch



Flameproof lamp

Part No. FT-006433

Description

This flameproof lamp provides illumination in locations potentially exposed to fuel vapours, such as behind the Fluid Transfer visual check fuel sampler. Alternatively available as an indicating lamp with various lens colour options. Available clear (standard), red, green, amber, blue. Accepts both 12 and 24 volt double pole (earth return) pygmy lamps.

- Rugged cast iron hot-dipped galvanised body
- Temperature-resistant toughened glass diffuser
- Type of protection: Exd IIB
- Temp info: T5 - -40°C to +50°C, T4 -40°C to +85°C
- Ingress protection: IP67 to EN60529:1992
- ATEX/EX rated.



24-volt engine hour meters

Part No. FT-005244

Description

An engine usage per hour management readout.

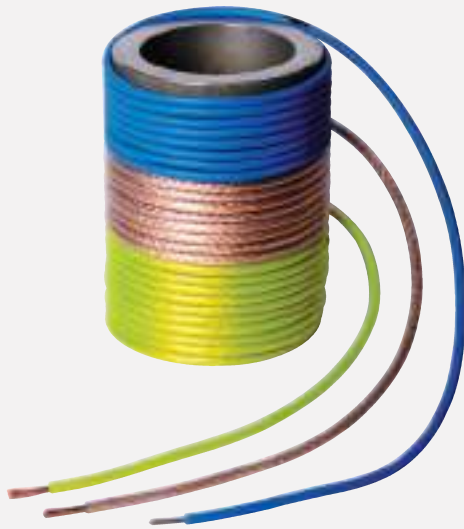

Earth bonding cable

Part Nos. See below

Description

- SK2665** (blue) Low temperature/unipren cable, working temperature -19 to -40 C
- DA9519** (clear coated copper braid) for working temperatures above -19 C
- DW20749** (high visibility) for use where increased luminosity is required.

All cable is available in meter lengths from 10-500m.

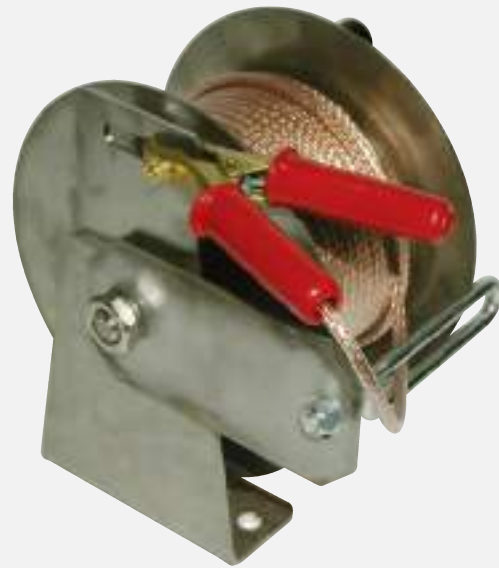

Hand rewind bonding reel

Part No. DCA12250

Description

Stainless steel construction with a rigid PVC hub. Internally protected electrical contact. <0.2 ohms resistance.

Bonding reels provide an electrical connection between refuelling equipment, aircraft, and bulking sites. Cable options are clear PVC-covered copper braid. This product is suitable for use at temperatures above -19° Celsius. For low temperature applications below -19° Celsius please use **SK2665** cable. For increased luminosity please use **DW20749**. All cables available in any length required.

Assembled and pre-cabled bonding reels are available as follows:

Copper braid

- DCA12250-1** 10m
DCA12250-2 20m
DCA12250-3 30m
DCA12250-10 40m

Low temp/unipren cable

- DCA12250-4** 10m
DCA12250-5 20m
DCA12250-6 30m
DCA12250-11 36m

High visibility cable

- DCA12250-7** 10m
DCA12250-8 20m
DCA12250-9 30m

Clip options:

- FT-005290** Small brass clamp 75mm
FT-005288 Mild steel plated clamp (MoD version).



Spring rewind bonding reel

Part No. DDA12221

Description

Robust maintenance-free construction. Stainless steel housing, spring and centre pin, aluminium alloy spring housing, dampened rewind system to prevent over-speed. Maximum resistance 0.50 ohms. Cable guide and rubber bump stop to reduce cable wear.

Bonding reels provide an electrical connection between refuelling equipment, aircraft and bulking sites. All cables available in any length required.

- | | |
|----------------|--|
| SK2665 | (blue) Low temperature/unipren cable, working temperature -19 to -40 C |
| DA9519 | (clear coated copper braid) for working temperatures above -19 C |
| DW20749 | (high visibility) for use where increased luminosity is required. |

Pre-cabled bonding reels are available as follows:

Copper braid

- | | |
|-------------------|-----|
| DDA12221-1 | 36M |
| DDA12221-2 | 30M |
| DDA12221-3 | 25M |
| DDA12221-8 | 40M |
| DDA12221-9 | 15M |

Low temperature/Unipren cable

- | | |
|-------------------|-----|
| DDA12221-4 | 36M |
| DDA12221-5 | 30M |
| DDA12221-6 | 25M |
| DDA12221-7 | 15M |

High-visibility cable

- | | |
|--------------------|-----|
| DDA12221-10 | 15M |
| DDA12221-11 | 25M |
| DDA12221-12 | 30M |
| DDA12221-13 | 36M |
| DDA12221-14 | 40M |

Clip options

- | | |
|------------------|--|
| FT-005290 | Small brass clamp 75mm |
| FT-005288 | Mild steel plated clamp (MoD version). |



Brass bonding clips

Description

- | | |
|------------------|--|
| FT-005290 | Small brass clamp 75mm |
| 3168-A | Electroplated brass earthing clip with cable clamping screws |

FTI Fueltronic

Part No. DB27591-1

FTi Fueltronic

Aircraft Fuelling Vehicle - Fuelling Control System

Fluid Transfer International (FTI) has drawn on its considerable experience within the aviation fuelling industry to develop a control system to monitor and control fuelling system status.

The **FTI "Fueltronic"** fuelling control system integrates all the functions commonly required on fuelling vehicles in a single system. These important functions include: Brake Interlock Monitor, Deadman Timer, Recovery Tank emptying and Emergency Engine Stop.

The **"Fueltronic"** control system operates via two control units mounted on the vehicle superstructure and within the chassis cab. The system provides full control and tailoring of all functions coupled with real-time monitoring and reporting information.



Cab-mounted Control Unit (CCU)

The Cab Control Unit (CCU), [above] is mounted in the cab. It uses a Liquid Crystal Display (LCD) to provide operation and fuelling system status information for the operator. The CCU also allows for a number of cab based Fuelling Control System switches and external electrical items to be integrated i.e. beacons and /or sounder.



Primary Control Unit (PCU)

The **Primary Control Unit (PCU)** is mounted on the top hamper and incorporates a comprehensive set of refuelling functions including:

- 16-Way Interlock Monitoring Unit
- Interlock Override Function
- Deadman Timer Unit
- Deadman Override Function
- Automatic Depressurisation Control
- Recovery Tank (Three Level Float) Control
- Fuel Meter Operational Status Control
- Product Tank High and Low Fuel Level Control
- Beacons and/ or sirens.

The integration of these systems in the PCU provides a significant reduction in pneumatic piping and electrical system wiring.

FTI Fueltronic

Part No. DB27591-1

FTi Fueltronic Fuelling Control System



Specifications

Both the Cab and top hamper [primary] CU support high-speed (38.4kbs) noise-resistant serial data transfer protocol and are able to recover serial communication automatically in case of intermittent wiring failure or electromagnetic interference. In case of a permanent wiring failure between the two CU's, the override control switches can be implemented. These features provide outstanding reliability for the entire system.

The CCU features an alphanumeric 20-character 4-line Liquid Crystal Display (LCD) providing the operator with visual data interface of operational and refuelling system status. Interlock switch status (in the form of unstowed interlock names) are identified, as well as the status of control switches such as: the interlock override, deadman override, fuelling mode and other important fuelling system inputs i.e. product tank floats etc. The CCU monitors the state of these local control switches and operates cab based items i.e. a beacon or sounder etc.

The ability of the CCU to directly operate relevant external loads ensures extreme flexibility of the entire system. Location of certain loads and control devices can be chosen accordingly either in the vehicle cab, or on the chassis without the need for intermediate wiring between the two CU. Both control units implement transistorized current load control (up to 10A each) ensuring sparkless operation and bringing the operational safety to a higher level.

The FCS system is designed for operation under a wide range of the power supply voltages. It complies with the new RoHS directive implemented on 1st July 2006. The system utilizes only RoHS compliant components.



Primary Control Unit [PCU] - internal view
Unit is ATEX approved

Approximate dimensions 200 deep x 260 wide x 260 high [cms]



total **aviation refuelling** solutions



Quality
Performance
Value for money

Electrically Safe Products



Fluid Transfer International are able to offer electrically safe products for supply onto new and existing aviation fuelling vehicles. Fti offer competitive rates and quality assured products.

Fluid Transfer offer a conversion kit with everything required to convert your vehicle to electrically safe.



Contact us now for a competitive quotation:

T: +44 (0)1453 833 381

E: sales@fluidtransfergroup.com

W: fluidtransfer.com



Filter High Differential Pressure Shut Down System

Part No. FT-009399

Description

This differential pressure shut down safety system is designed to comply with JIG bulletin No. 58 of January 2013. This states that a differential pressure switch must now be fitted to all filter monitors and is also recommended for all filter water separators in order to automatically cut off fuelling once the differential pressure reaches a critical level, preventing any possibility of contaminated fuel passing onto an aircraft.

The critical differential pressure can be adjusted from manufacture to suit either filter water separator (15 psi) or filter water monitor (22 psi) installations, or indeed any chosen differential pressure between 3 and 58 psi. The Fluid Transfer differential pressure shut down system has been designed to be easily and safely retrofitted to all vehicles.

The all pneumatic design is "fail safe", and with no electrical components avoids ATEX compliance issues. Installation is simply achieved on refuelling vehicles (of any manufacturer) by tapping into the Ø6mm high and low pressure supply lines to the existing differential pressure gauge. The control box containing the visual detectors, test system and key switches, together with the differential pressure switch, can be mounted to the existing instrument panel or an alternative suitable location.



ATEX LED Spot Lamp

Part No. FT-009734

Description

The Fluid Transfer ATEX zone 1 approved Ex-d spot lamp has been specifically designed for use on mobile fuelling applications. This LED lamp contains 3 super-bright LEDs which produce a crisp white light with an 11° beam angle.

A Ball joint mount allows the lamp to be fixed in a multitude of positions. It is locked into position by hand using a single lever. This provides optimal manoeuvrability and also allows great ease of use as no tools are required to adjust the lamp positioning.

Part Number – FT-009253
Description – Remote Area Lighting System

Remote Area Lighting System, the world's only battery powered, safety approved LED remote area light. Its 1500 lumens illuminate hazardous locations, and with two power settings the 9435 extends burn time up to 10 hours of clean even light. An compact, 7.9 kg ATEX approved portable lighting that features a swivelling telescope mast that extends to nearly 91cm.

- Portable & rechargeable Worklight
- Dual power mode
- 1500 lumen output on high
- 750 lumen output on low
- 10 hours of run time in Economy mode
- Silent Operation
- No Fuel or Fumes
- Fully extendable mast with 360 degree rotating head
- LED High Flux Energy Efficiency
- Atex approve to zone 2.

Dimensions & Weight

- Head Length 16.5cm
- Head Width 20cm
- Head Depth 6.5cm
- Width Closed 20cm
- Length Closed 40cm
- Height Closed 23cm,
- Mast Height Extended 82cm
- Cord Length 35cm
- Weight 7.98kg



Intrinsically Safe hose reel HEPC nozzle stowage - electrical interlock.

Part No. FT-006812

The Fluid Transfer HEPC nozzle stowage is an integrated unit which provides a positive locking engagement nose protection and in-built ATEX approved inductive proximity sensor, Fabricated with an Aluminium base and bowl with high quality 316 stainless steel plates for the brass interlock bezel.



Part Number: FT-007887

Colours available: Green, Red, Yellow, Blue & White

Description: Intrinsically Safe LED lights

The 50 mm general-purpose indicator is available in both AC and DC supply voltage options.

- Rugged, cost-effective and easy-to-install indicators
- Illuminated dome provides easy-to-see operator guidance and indication of equipment status
- Compact devices are completely self-contained — no controller needed
- 18 to 30V dc operation; 85 to 130V ac operation
- Displays up to three colors
- Immune to EMI and RFI interference



Emergency Stop Assembly

Part No.

Description

- Rugged design, easy installation with no assembly or individual wiring required.
- Push-to-stop, twist-to-release, or pull-to-release operation per IEC60947-5-5
- Latching design complies with ISO 13850; direct (positive) opening operation per IEC60945-5-1
- Compliant with ANSI B11.19, ANSI NFPA79 and IEC/EN 60204-1 Emergency Stop requirements.
- "Safe Break Action" ensure NC contacts will open if the contact block is separated from the actuator.
- 8-pin M12/Euro-style Quick Disconnect.
- Models with YELLOW and RED indication of actuation (armed or depressed/latched button) and machine status (optional).



Intrinsically Safe Barriers

Part No. FT-007308, FT-007309, FT-007310

Description

- 2-channel isolating switching amplifier with removeable terminal blocks.
- Intrinsically safe input circuits EEx ia.
- Area of application acc. to ATEX: II (1) GD, III 3 G.
- Approved for installation in zone 2, however the device must be installed in a housing which complies with the requirements of EN 60079-15 with a minimum protection degree of IP54.
- Functional safety up to SIL 2 (acc. to EN 61508)
- Input circuit monitoring for wire-break and short-circuit (can be disabled)
- Galvanic isolation between input circuits, output circuits and power supply.
- Two transistor outputs for switching up to 30 VDC at a max. frequency of 5kHz.
- Selectable NO/NC output function.
- Universal supply voltage (20...250 VAC / 20...125 VDC).
- Devices also available with cage clamps, Type designation: IM1-22Ex-T-CC, Ident-no.:7541235

The isolating switching amplifier type IM1-22Ex-T is a dual channel device featuring intrinsically safe input circuits.



Alarm Safe Sounder

Part No. 6156862

Description

This mini-alarm is an ATEX and ICEC_x certified intrinsically safe sounder which produces a loud warning signal in hazardous areas.

The IS-mA1 mini-alarm sounder has been designed to operate in a hazardous area from a 24V DC supply via 28V 93mA resistive ATEX and ICEC_x certified Zener Barriers or Galvanic Isolators.



Inductive Sensors

Part No.

Description

Inductive sensors detect metal objects contactless and wear-free. For this purpose they use a high-frequency electromagnetic AC field that interacts with the target. The sensors hosting a ferrite core coil generate the AC field through an LC resonant circuit.

- M12 x 1 Connector
- ATEX category II 1 G, Ex zone 0
- ATEX category II 1 D, Ex zone 20
- Threaded barrel, M30 x 1.5
- Chrome-plated brass



Instantaneous rate-of-flow indicator

Description

- For bulk flow meters
- Please contact us with details of meter manufacturer and model.



6" and 10" Gauge and float assembly

Part No. Various

Description

- 6" and 10" dial face and corresponding float gauge
- All contents volumes catered for.



Series 1871, 7697 or 7671 pulse transmitter

Description

- For mounting pulser on series 7887 meter register
- 3-bolt design.



Sho Flo Indicator

Part Nos. See below

Description

Gives simple at-a-glance indication of the fluid/air flow within a pipe or hose. The gunmetal or stainless steel body contains a central passage which passes through a chamber containing a moulded ball. The ball is viewed through a borosilicate glass dome secured via a gunmetal ring to the body.

Until the air/liquid starts to flow the moulded ball remains hidden within its tube. The passage of liquid through the tube causes the moulded ball to rise in the tube and start bobbing as it becomes visible in the glass dome. The simplicity of the design minimises wear, ensuring exceptional reliability and long life. The Sho Flo indicator is suitable up to a maximum working temperature within the glass dome of 120° Celsius. Will also act as a non-return valve.

- Rugged gunmetal body
- Borosilicate glass dome
- Nylon moulded ball
- Maximum working pressure 7bar (150psi).

Four sizes:

12.7mm (½") (DA26302-1)

19mm (¾") (SK-3400-2)

25.4mm (1") (DA26302-2)

38mm (1½") (DA2630-3)



Sho Flo Indicator ½" BSPFF

Part Nos. FT-005567

Description

As used on our standard 3800LPM Meteor Dispenser.

Also available in ¼", 3/8", ¾", 1" & 1½"

This sight flow indicator is ideal to visually check the flow presence, colour and condition of a liquid, gas or condensate.

Constructed in a high quality stainless steel body with viton 'O' rings. A single sided stainless steel indicator that can be used on pipe sizes from 8mm (¼") to 40mm (1½").



Gauges for measuring pressure and vacuum

Part No. Various

Description

- For hydraulic and pneumatic applications
- Popular sizes include 38mm, 63mm and 100mm
- Popular ratings include 160, 200, 300 & 3000 psi
- Gauges also feature BAR ratings
- Panel mounted or bottom entry
- Connection sizes 1/4" or 1/2" BSP.



Differential pressure gauge

**Part No. FT-005250
FT-005249 (depicted)**

Description

- Aluminium alloys/stainless steel construction, fitted with Viton seals
- Maximum working pressure (**FT-005250**) 20.7bar (300psi)
- Maximum working pressure (**FT-005249**) 10.4bar (150psi)
- Cylinder test pressure 82.7bar (1200psi)
- Working temperature range from -40 to +70 Celsius.

Thanks to its simple design the calibration of this gauge is not affected by pressure surges. The gauge is fitted with a 10 micron filter to ensure no dirt particles enter the cylinder. Design incorporates an integral push-button free movement test/thermal relief valve, preventing the build-up of potentially damaging thermal pressures. This meets the test requirements for AP11581 standards.



Satam positive displacement meters

Part No. ZC17

Description

The Satam positive displacement meter is used to measure "white" petroleum products such as fuels, bio-fuels and refined liquid hydrocarbons. Its simple design, two pairs of blades and one moving rotor, makes this meter exceptionally robust and allows the user to make significant savings on maintenance costs.

- Minimal pressure loss, 0.3-0.5 bar at maximum flow rate
- Simple and robust design
- Accuracy of measurement guaranteed over a period of many years with no drift in the calibration curve
- A wide range of accessories available for performing customized measurement applications.

Maximum flow rate per meter:

ZC17-12	200 l/min
ZC17-24	400 l/min
ZC17-48	800 l/min
ZC17-80	1333 l/min
ZC17-150	2500 l/min
ZC17-250	4166 l/min



Veeder Root Mechanical Register

Part No. FT-005488

Description

7887 Series Register

- Available with or without ticket printer
- 5-digit display with totaliser
- Litres or US gallon versions
- With or without pulser (please specify).



Register Head Models

Part No. Veeder Root EMR Electronic

Options:

- Volume only
- Volume with temperature compensation
- Volume and currency
- Volume, currency and temperature compensation.



Visual check fuel sampler (VCFS)

Part No. DDA11460 2l
DDA11432 3,3l
DDA11501 4l
DDA11480 6l
DDA11502 8l

Description

Available as 2, 3.3, 4, 6 or 8 litre units

The Fluid Transfer visual check fuel sampler (VCFS) is a closed-circuit fuel sampling system designed to provide a safe, easy and convenient method of carrying out the industry standard (clear and bright) visual examination of aviation fuel.

The 3.3 litre unit is a standard VCFS, the optimum size for vehicle applications – ie it is large enough to obtain a complete sample yet compact enough to fit unobtrusively on a small hydrant dispenser. The mechanical design prevents vibration and thermal expansion from overstressing the glass tube. The hinged lid is large enough to allow the inside of the glass and the base to be cleaned for ease of maintenance and assured performance.

This unit does not include the water detector assembly or the hydro/thermo support assembly.

Also available are a thermometer/hydrometer housing (**DBA11465**) a shell water detector (**DBA11416**) and a flameproof lamp assembly (**FT-005224**).

- Aluminium body
- Boron silicate glass
- High nitrile seals.



Hydro/thermo support assembly

Part No. DBA11465

Description

- Hydrometer and thermometer housing used in conjunction with any VCFS 3.3 litres or greater
- Enables the sample temperature and density to be measured
- Not suitable for 2.0l unit.

(Hydrometer and thermometer sold separately).



Visual check fuel sampler (VCFS)

Part No. FT-004228 4 lt

Description

The standard VCFS unit, modified top connection for venting.



Replacement glass for VCFS

**Part No. DAM11458 (2l)
DAM11427 (3.3l)
DAM11496 (4l)
SK885 (6l)
DAM11499 (8l)**

Description

Length to dictate volume.



Shell water detector assembly

Part No. DBA11416
DAM11417 – elbow

Description

A self-sealing valve assembly Shell water detector unit allowing a fuel sample to be drawn from the base of the VCFS when used with connecting elbow **DAM11417**.

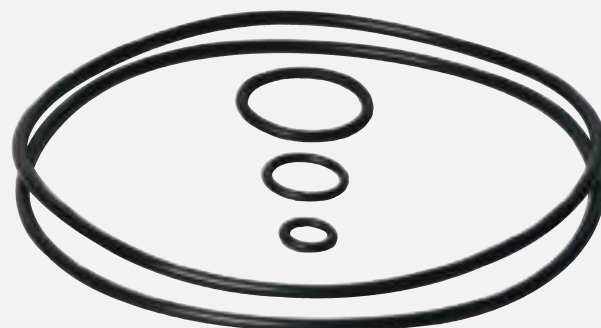

Replacement O rings for visual check fuel sampler

Part No. SK1478

Description

Repair kit for VCFS, various sizes.



Esso water detector assembly

Part No. DBA11402
DAM11417 – elbow

Description

A self-sealing fuel sampling water detector unit allowing a fuel sample to be drawn from the base of the VCFS using the Esso/Exxon test tube system when used with connecting elbow **DAM11417**.



VCFS lid, spinning

Part No. DAM11430

Description

Replacement lid for 2 / 3.3 / 4 / 6 / 8 litre units.



Hydrometer

Part No. Various

Description

To evaluate the density of liquid to ascertain possible contamination.



Thermometer

Part No. Various

Description

To determine the temperature of the fluid enabling an accurate density check.



80 and 160-litre visual fuel sampler

Part No. DC9621 (160l)
DC20000 (80l)

Description

Pipework and flanges are of 304 stainless steel construction. The stainless steel base is conical in profile to ensure complete product drainage. The incoming fuel is caused to vortex, concentrating debris and/or suspended water at the centre of the vessel to make it easier to see. An engraved level indicator gives a measure of the sample volume. The inlet pipe is fitted with a self-sealing SWD valve assembly designed to accept the shell water detector syringe *DBA11416*.

Base incorporates a drain valve, a fill port, a sampler draw-off connection and a mounting flange. An integral emptying valve is built into the base, allowing connection to a gravity line or a hand-operated pump for emptying.

- Stainless steel construction
- Borosilicate glass
- High-nitrile rubber seals.



Fuel sampler

Part No. DDA12500

Description

- SSAFCON is a unique monitoring system for portable line sampling of aviation fuel to determine particulate contamination and colour rating
- Filter tests for particular contamination, also colour rating for aviation fuels, in-line test – i.e. no fuel disposal or waste requirement
- Improved operator safety.



Shell water detector tablets

Part No. DA27371

Description

The Shell water detector tablet is a device for determining the presence of finely-dispersed undissolved water in jet fuels at concentrations lower than those normally detectable by visual examination. Water dispersions of this type can result from the emulsification of a water/fuel mixture during pumping, or from precipitation of dissolved water due to a fall in fuel temperature.



Spring release valves, BSPP/NPT thread

**Part No. DA27463-1 to -8 BSPP
DA27463-20 to DA27463-27**

Description

- Stainless steel construction
- 1/4" to 2" female threaded end connections
- Minimum pressure rating 20.8 bar (300 psi)
- Operating temperature -20° to +40° Celsius
- Blowout-proof stem design and adjustable gland packing to ensure optimum operating torque.

BSPP Thread

DA27463-1	1/4"
DA27463-2	3/8"
DA27463-3	1/2"
DA27463-4	3/4"
DA27463-5	1"
DA27463-6	1 1/4"
DA27463-7	1 1/2"
DA27463-8	2"

NPT Thread

DA27463-20	1/4"
DA27463-21	3/8"
DA27463-22	1/2"
DA27463-23	3/4"
DA27463-24	1"
DA27463-25	1 1/4"
DA27463-26	1 1/2"
DA27463-27	2"



Ball valve

Part No. PIA2355-1 to -7

Description

- Nickel-plated brass ball valve
- Viton 'O' Ring
- Chrome plated ball
- Silicon free
- Temperature range -10° to +170° Celsius
- Rated 500psi
- Female couplings

PIA2355-1	3/4"
PIA2355-2	2 1/2"
PIA2355-3	2"
PIA2355-4	1 1/2"
PIA2355-5	1"
PIA2355-6	3/8"
PIA2355-7	1/2" BSPTF



Non-return valves with or without equalisation tapping

Part Nos. DB4956 and FT-001140

Description

- Solid brass construction
- **DA4956** is drilled to enable pressure equalisation within the Venturi pressure sense line
- 1/2" BSP.



Cam and groove couplings

Part No. Various

Description

- ½" to 4" cam and groove and dust cap assembly (available as separate items)
- Designed to complement **DA27463** spring return ball valves or similar
- Aluminium construction – a stainless steel version is available on request.

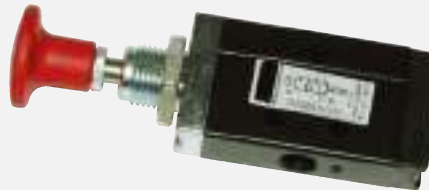

Pneumatic spool valves

Part No. Various

Description

- Pneumatic spool-operated valves for various applications
- Please call to discuss your requirements.



Hose reel and platform spool valves

Part No. SK1113-2
103610A1A210 (complete replacement handle assembly)
06.093.27610 (Replacement Gaiter Rubber)

Description

- Hose reel/platform lift used to control hydraulic oil flow in either feed/static (locked) or return feed mode
- These valves increase or reduce the hydraulic pressure and activate the required operation
- Manufactured from cast iron and nickel-plated components.



Manually operated hydraulic valve

Part No. FT-005252

Description

- Complete with a pneumatic pilot to change valve state
- Commonly used in recovery tank emptying.



Coalescing filter bowl

Part No. FT-005258

Description

- Water separation from the pneumatic system.



Control valve, single or two-way flow

Part No. FT1251-5-38V (black top, single direction)
FT1251-2-38V (blue top, dual direction)

Description

- Nickel plated brass construction
- 3/8" BSPF fit
- 30 lockable settings from fully closed to fully open
- Black top indicates single direction of flow (ie with internal non-return valve)
- Blue top indicates dual direction of flow.



Footvalve cable

Part No. Various lengths available

Description

- Robust design and construction
- Braided stainless steel wire, sleeved in heavy duty rubber and available in various lengths from 1-6m in 10 mm increments
- Assembly has an integrated cable adjustment.



Emergency valve bottom operator

Part No. FT-005304 single
FT-005305 double

Description

Internationally regarded as the industry standard, the range of bottom operators provide selective remote control of one to six emergency valves to ensure positive control during liquid discharge.



API adaptor

Part No. FT-00064

Description

Designed for bottom loading, this API adaptor has a one-piece body, hard anodised nose ring and flat bottom. These valves set the standard in terms of design features and build quality.

- Hard anodised replaceable and indexable nose ring
- Flat bottom of valve body ensures complete product drainage
- Conforms to API RP1004 for total compatibility with API couplers
- Lightweight diecast aluminium construction for increased payloads
- Viton seals standard for compatibility with high-octane fuels and additives.



Stainless steel buckets

Part No. FT-005479 – 8l
FT-005480 – 12l
FT-005481 – 15l

Description

- Stainless steel buckets used in low point flushing, purging and sampling of aviation fuel
- All buckets are complete with a static bonding cable and clip for safe use
- Internal visual volume check.



Water detector probe

Part No. FT-005259

Description

- Capacitive proximity sensor, contactless, wearless, reverse polarity and short circuit protection
- Working temperature range from minus -20° to + 65° Celsius
- CENELEC compliant, IP67 67 rated.



Continuity tester

Part No. DBA11801

Description

The Fluid Transfer continuity tester is designed for workshop use only, as it uses a higher voltage than most other units to give truer and finer detection. Readings below 5 ohms are deemed to be a pass. Figures from 5-10 ohms are deemed a pass but the system continuity needs attention. A result of 10 ohms or more is deemed a failure. The equipment should then be withdrawn from use, preventing any possible hazardous situations developing.

- Simple-to-use 3-light system – green light = pass, amber light = check, red light = fail
- Robust design, compact and lightweight for ease of use and portability.



Millipore adaptor

Part No. DC2257

Description

- Solid construction in-line fuel sampler
- Stainless steel sample point
- Pressure gauge to ensure no greater pressure than 5 bar at point of sample
- NATO stock No 6630-99-224-5322.



total **aviation refuelling** solutions



Quality
Performance
Value for money

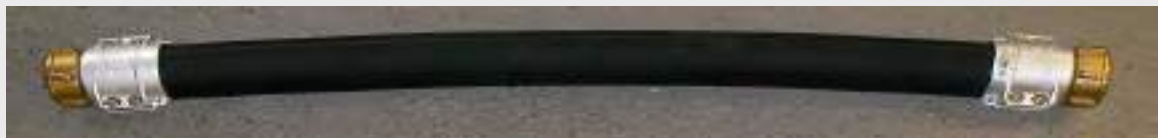

AVIATION FUEL HOSE ASSEMBLY, TEST AND MANAGEMENT SERVICES

In our industry quality, performance, service and value for money is essential.

Fluid Transfer International are able to service your complete aviation hose requirements utilising our own in-house test and assembly facilities to deliver EN1825 hose sets, quality assured and at truly competitive prices.

Being one of the aviation industries largest OE users of aviation hose assemblies, FTi require quality assured products at the right price and we know our customers demand the same.

Contact us now for a competitive quotation:

T: +44 (0)1453 833 381

E: sales@fluidtransfergroup.com

W: fluidtransfer.com



In-house hose assembly and test facilities.

Supported by major brands of Aviation Fuel Hose to EN1825 standards.

Assembly and test facility for up to 6" (150mm) diameter and 160ft (50m) length

Type "C" Refuelling EN1825 1" – 4"

Type "E" Defueling/Suction EN1825 1" – 4"

Type "F" Fuelling/Defueling EN1825 1" – 4"

Also full range of MoD hose assemblies

Other sizes, types on request:

Extensive range of standard and speciality fittings available:





Type C and Type F Hose

**Part No. HOSEC
HOSEF**

Description

Type C delivery hose is a soft-walled textile of reinforced construction. Available in the following dimensions:

25C	25mm ID / 37mm OD
32C	32mm ID / 44mm OD
38C	38mm ID / 51mm OD
50C	50mm ID / 66mm OD
63C	63mm ID / 79mm OD
75C	75mm ID / 91mm OD
100C	100mm ID / 116mm OD

Type F fuel/refuel hose has a nylon helix, permitting both delivery and suction operations from the same unit. Available in the following dimensions:

25F	25mm ID / 41mm OD
32F	32mm ID / 48mm OD
38F	38mm ID / 54mm OD
50F	51mm ID / 67mm OD
63F	63mm ID / 81mm OD
75F	76mm ID / 93mm OD
100F	102mm ID / 120mm OD

- Assemblies are made to customer requirements from 1m to 40m long
- End fittings to suit application.
- Compliant with BS EN 1825.



High-quality safety clamp hose-end fittings

Part No. Various

Description

Reusable end-of-hose fittings, consisting of a forged male or female hosetail to suit hose ID, secured via a two-piece forged aluminium clamp assembly. All components manufactured and tested in house to ensure quality.

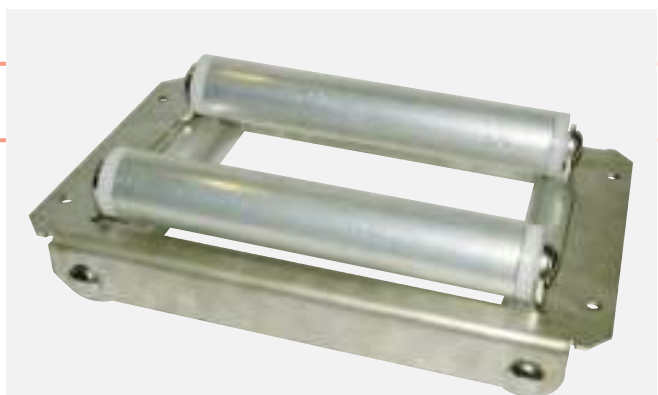

Hose roller box assembly to suit application

Part No. Various

Description

Assists extraction and rewinding of the hose unit and acts as a guide to ensure free travel of hose, preventing snagging or kinking. Standard size is 530mm x 160mm, but any bespoke size up to 1m sq is available.

- Stainless steel frame work
- Aluminium rollers
- Nylon roller bush.



Hose beads

Part No. Various

Description

Easy to assemble with sturdy nylon wear-resistant body. Brightly coloured for visibility. Brass fittings included.

Hose beads come in three standard sizes:

DA26704	38mm
DBA11502	50mm
DB4042	63mm
DBA 11508	75mm (available in black only)
DBA11504	100mm

Fluid Transfer hose beads are designed to reduce fuelling hose wear caused by abrasion when the hose is dragged across the ground. Fitted to the surface of the fuelling hose, the beads raise the hose from the ground, reducing the resistance when extracting/retracting the hose for operation. The nylon construction is tough and wear-resistant, prolonging the life of the hose.



Hose reel HEPC nozzle stowage with electrical or pneumatic interlock

Part No. **DCA10214**
DCA10216

Description

The Fluid Transfer HEPC nozzle stowage is an integrated unit which provides a positive locking engagement nose protection and a built-in interlock switch. The interlock can either be an electrical proximity switch (**DCA10214**) or a pneumatic valve (**DCA10216**). The stowage consists of a cast aluminium base on which is mounted a tapered nozzle guide. The nozzle locks on to a bayonet connector made of high strength aluminium bronze alloy. When the nozzle is stowed a central nylon plunger operates an interlock switch concealed in the base.

- Cast aluminium base
- Plated steel guide
- Aluminium connector
- Two sizes to suit Avery Hardoll or JC Carter nozzles.



Quick disconnect / 2½" nozzle isolating valves

Part No. DCA10320
DBA11706

Description

The Fluid Transfer nozzle isolating valve is designed to facilitate "dry-break" strainer inspection and/or nozzle removal, eliminating the need to drain down the hose. This unit is light, short and easy to operate. A positive lock in the open and closed positions is provided, along with a telltale which indicates if the valve is in the open or closed position.

- | | |
|-------------------|--|
| DBA11706 | 2½" BSP male/female with drag ring (for reel hose nozzles) |
| DBA11706-1 | Without drag ring (for deck hose nozzles) |
| DCA10320 | 2½" Quick disconnect with F-profile flight refuelling attachment without drag ring |
| DCA10320-1 | Quick disconnect including drag ring |

- High-strength aluminium alloy
- High-nitrile seals
- Low pressure drop – less than 0.2bar (3psi) at 1800 litres per minute
- Operating temperature range -25° Celsius to +80° Celsius
- Suitable for pressures up to 20 bar (300psi) in either the open or closed mode.



HEPC refuelling couplings

Part No. Various

Description

These HEPC into-plane refuelling couplings comply to British Aerospace specification 4C14, ISO R45 and NATO Stanag 3105 for aircraft refuelling connectors. Available with stick/ring or spread handles.

Avery Hardoll, Whittaker or J C Carter design available.



Spiral Guard hose protection

Part No. FT-005460 – 32mm yellow
 FT-005461 – 2" yellow
 FT-005462 – 2" hi-vis
 FT-005463 – 4" yellow

Description

Heavy duty PVC-construction Spiral Guard provides excellent point of contact protection for fuel hoses.

- Protects against excessive wear on abrasive surfaces and assists with the extraction and retraction of the hose unit
- Easily assembled and removed
- Available in 32mm, 50mm and 90mm, capturing all standard hose dimensions
- All available as 20m lengths.



Overwing nozzle

Part No. G180

Description

- 3 quick-change spout configurations (1", 1.5" and flared available and interchangeable)
- 100-mesh stainless steel strainer – easily accessible for inspection
- Factory tested and traceable – each nozzle flow and leak tested at factory and assigned a serial number
- Nozzle is free of yellow metal and plastic components
- Valve design makes flow control easy
- Non-metallic, fuel-resistant dust cap.



Trigger nozzle

Part No. ZVA 32

Description

- Hose inlet size: R 1½" BSP male
- Hose inlet type: swivel
- Spout length: 240mm.



Hosereel - single or double volute

Part No. Various sizes available

Description

Enables a maximum length of 60m x 63mm hose to be used.

- Stainless steel fluid path
- Single pedestal for simple, compact installation
- C/w heavy-duty ball-raced swivels and integral hydraulic wind reassembly.

1900mm diameter (30m x 63mm) single volute
 1500mm diameter (30m x 63mm) double volute
 1750mm diameter (30m x 50mm) single volute
 1500mm diameter (30m x 38mm) single volute



Chain tensioned spring

Part No. FT-005271

Description

- Robust plastic housing
- Stainless steel spring and screws fitted
- Compact unit design to suit installation within restricted space
- Non-corrosive parts
- To suit chain pitch up to 3/4"
- Chain tension travel distance (after fitting) is 40mm.



Gearbox clutch assembly

Part No. SK2184-2

Description

21-tooth sprocket hose reel clutch/gearbox assembly.



1/2" chain for hosereel

Part No. FT-005281

Description

Replacement hose-reel chain.



Hydraulic motor

Part No. FT-005282

Description

Used on our hose reel assemblies

- Simple two-bolt mounting
- 25mm steel shaft
- 1/2" BSP ports
- 165 bar rating
- Max revolutions 1100 rpm
- Max torque 520 Nm
- Compact design.



Helicopter refuelling nozzle

Part No. G457-040

Description

The G457 helicopter refuelling nozzle was originally developed for military applications. It is designed to ensure that fuel cannot be accidentally delivered into the engine air intake during hot refuelling.

- High-level shutoff by fuel sensor in spout, also equipped with anti-froth device
- Supplied complete with 100-mesh inlet strainer, dust cap and grounding wire
- Flow control mechanism can handle pressure to 110 psi
- NATO specification
- Available with curved or straight spout (other configurations available).



Reflective hose jacket

Part No. DB27021

Description

- High-quality materials used throughout
- Ultra high-reflective strip for excellent night/ poor visibility vision
- Fade resistant bright orange base giving excellent daytime visibility
- Encapsulated in plastic to prolong the life and to ease cleaning
- Secure fastening via Velcro strips
- Quick and easy removal for hose inspection.

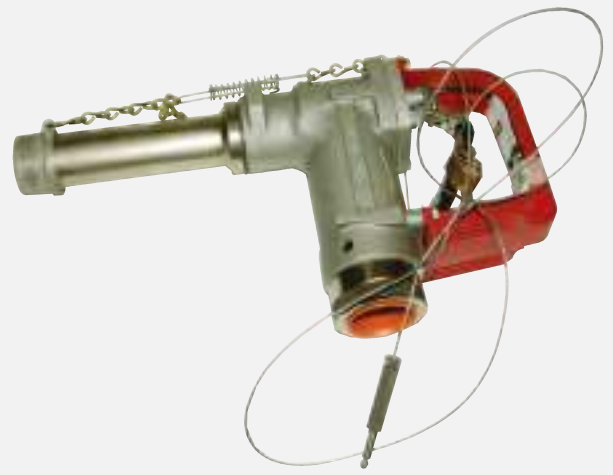

Trigger nozzle OPW

Part No. FT-005458

Description

- Aluminium body and guard
- Brass or stainless steel inlet swivel
- Stainless steel/brass/Acetal internal composition
- Nitrile/Vulkollan seals.

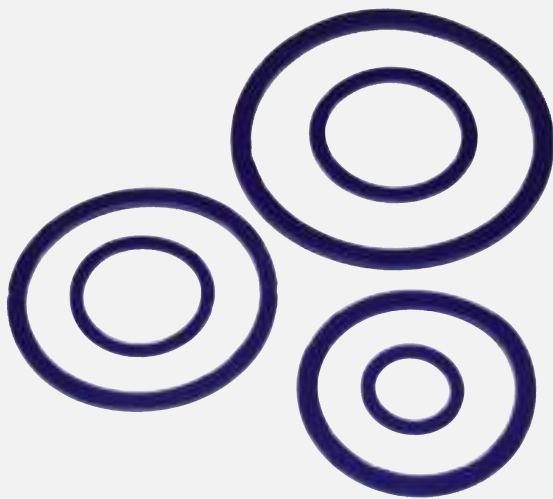

Polyurethane washers

Part No. Various

Description

Hose and trigger nozzle seals, sizes available from 3/4" to 4".



Jet A1 spout with flared end

Part No. FT-005256



Defuelling spout for ZVF

Part No. FT-005257 (Elaflex)



Wear ring/drag ring
(choice dependent on HEPC fitted)

Part No. Various

Description

Heavy duty nylon construction. Helps to prevent wear or damage to the HEPC head when rewinding the hose.



Hydrant dispenser inlet couplings

Part No. Various

Description

A series of robust construction hydrant intake couplings, offering low weight, low pressure drop and high stability. Designed to comply to all API test standards. For use with aviation kerosene and gasoline.

- Heavy-duty polyurethane bumper to resist abrasions
- Smooth opening and closing operation
- Maximum working pressure 15bar (225 psi)
- Test pressure 23bar (338 psi)
- Short or wrap-around handle options available.



Hose unit couplers

Part No. Various

Description

- Dry aviation coupling to ISO45/NATO STANAG 3105 standard
- Body manufactured from high-strength aluminium or stainless steel, with Viton seals
- Working pressure 10 bar (150 psi), working temperature range -3°C to +60°C
- Threaded coupling size from 1" to 6" in BSP or NPT thread.



Intake coupling Easi-lift

Part No. Various

Description

The Fluid Transfer intake coupling Easi-lift is a mechanical "over centre" device attached to the dispenser's subframe. It consists of an actuating handle, an enclosed height-adjustable lifting table and a spring-loaded safety latch.

The actuating handle is located at a convenient height for the operator. The cradle design receives a typical intake coupling, a complete integral secondary pressure control and deadman valve. The intake coupling stowage can be interlocked to ensure correct stowage.

Reduced lift load provides a 2.5:1 mechanical advantage.

- Lightweight zinc-plated steel design
- Stainless steel bucket
- Positive rubber grip handle
- Hydraulic and in-line (not proud of the vehicle) versions available.

Manual mechanical version shown.



Pressure Test Pump (air powered)

Part No. **DC27530** Hose
DC27530-HP

Description

A lightweight and portable air-powered pressure test pump designed for in situ testing of refuelling delivery hose and vehicle pipework integrity to JIG/API standard periodic testing requirements. This unit can safely be used in hazardous areas to test vehicles with the standard (2½") test coupling **DBA10605**. Alternatively it can be used with adaptor kit **SK3256**. The air-driven hydraulic piston pump is fed from an external compressed-air supply source via an adjustable air pressure regulator and filter. Fuel is pumped through a wire-reinforced hose to an adapter (hose end pressure test coupling **DBA10605**).

- Dry-break connections
- No need to drain/remove hoses
- Rated for testing up to 24bar (350psi) – a 40bar (600psi) option is available (**DC27530-HP**).



Hose pressure test coupling

Part No. **DBA10605**

Description

This adaptor is designed to be used in conjunction with air-powered pressure test pump **DC27530**, permitting connection with hose end pressure controllers to allow in-situ testing. The Pressure test coupling may also be used in conjunction with underwing pressure refuelling nozzles, which are fitted with integral spring set pressure regulating/surge controllers.

- Aluminium body with scalloped hand grip
- Brass NATO standard adaptor
- ¼" BSP test pump connection tapping
- Standard profile 3-point bayonet adaptor to suit all proprietary hose end pressure control nozzles.



Recovery tank emptying system

Part No. Various part numbers, ranges from 20-250l (standard size 120l)

Description

An environmentally and economically-sound option for fuel sampling via the closed-circuit visual check fuel sampler unit (VCFS) DDA11432.

- Sturdy stainless-steel construction
- All internal welds ground flush to enable free draining and ease of cleaning.



Sense lines

Part No. FT-005283 (6mm)
FT-005284 (10mm)

Description

- High-temperature fuel sense line
- Safe operating range -40 to +135° celsius
- Type C nitrile inner core, fibre braid reinforcement, completed by a type A neoprene outer core.

Fittings:

6mm tail female fitting **FT-005285**

6mm tail male fitting **FT-005287**

9mm tail female fitting **FT-005286**

9mm tail male fitting **FT-005485**



Flexible expansion joints

Part No. DB2247

Description

Suitable for use in both pressure and vacuum applications. If used in a high vacuum situation it is recommended that stainless steel vacuum support rings are fitted. Suitable for use in pipework situations subject to vibration, misalignment and expansion.

- Maximum working pressure 10 Bar (145 psi)
- Maximum test pressure 16 bar (232 psi)
- Flexible Nitrile-lined rubber centre mounted between two aluminium DIN flanges
- Chloroprene electrically conductive outer 1k to 1m ohm.

DB2247-1	50mm joint
DB2247-2	80mm joint
DB2247-3	100mm joint
DB2247-4	150mm joint



Aviation Tank Units Tank Unit Cap Assembly

Description

The tank units come with the following fittings:

DCA10460	3" ASA flange
DCA10461	80mm (3") DIN flange
DCA10462	2½" BSP Female thread
DCA10463	3" BSP F
DCA10464	2½" NPT Female thread
DCA10465	3" NPT F
DBA10440	Tank unit caps are pressure-assisted sealing units

Fluid Transfer 104 Series tank units are lightweight (non-yellow metal) self-sealing valves, designed to meet the stringent demands of the aircraft refuelling industry. They feature a spring-returned plunger with integrated circumferential seals. The action of engaging the coupling forces back the plunger, breaking the seal and allowing the liquid to flow through the coupling.

Applications include bottom loading points on mobile fuelling equipment, fixed-installation supply outlets and coupling points on portable fuelling trolleys, test rigs and meter providing rigs.

The valves conform to British, US and ISO coupling connection and strength requirements and are compatible with all makes of pressure refuelling nozzles.

Maximum working pressure 10.4 bar (150psi)
Maximum Test pressure 20.8 bar (300psi).

- Low pressure drop
- No plated components in contact with fuel and no internal fittings to prevent fuel contamination
- High nitrile (BUNA-N) seals.



80mm and 100mm lightweight aluminium swivels

Part No. DBA11901 - 100mm
DBA11902 - 80mm

Description

The Fluid Transfer lightweight aluminium swivel is designed to give long maintenance-free service in light moment loading applications such as small hoses on elevated deck platforms. The flow path is aluminium alloy, preventing any contamination of the fluid product. The fluid seals are designed to provide minimal resistance to rotation, allowing ease of use while remaining impervious to kerosene-based fuels. The reduced weight and compact size allows the unit to be fitted in confined spaces or where space and weight are at a premium.

- Aluminium alloy body fitted with Viton seals
- Stainless-steel loose ball-type bearings, packed for life – no lubrication required
- Electrical continuity through unit
- Maximum working pressure 10.4 bar (150psi)
- Maximum test pressure 20.8 bar (300psi)
- Both models have DIN 28460 mounting flanges.



80mm and 100mm heavy-duty stainless steel swivels

Part No. DC1233 - 80mm
DC1113 - 100mm

Description

The Fluid Transfer heavy-duty swivel is designed to give long maintenance-free service under the most arduous operating conditions. The heavy-duty construction of the swivel makes it robust enough for applications where mechanical radial loads are imposed. The swivels are used extensively on hydrant dispenser intake booms and pantographs, where safety and performance cannot be compromised.

- Stainless steel inner/plated steel outer
- Maximum working pressure 10.4 bar (150psi)
- Maximum test pressure 20.8 bar (300psi)
- Viton seals
- Sealed for life (ball race type) bearings, giving low swivel resistance and high wear resistance
- Seal design provides low resistance to rotation
- All components in contact with the fluid are constructed from stainless steel
- Both models have DIN 28460 mounting flanges.



Suction fuel strainer elements

Part No. Various

Description

- ½" / ¾" / 1" BSP male/female fittings
- Operating temperature range -25° to +110° Celsius
- Conforms to ISO filtration standards
- Robust nylon end cap and fittings with galvanised steel support tube
- Max flow rate 900 lpm.



Butterfly valve

Part No. Various

Description

- 2" / 3" / 4" / 6" options available
- Solid cast construction with high nitrile seals
- Pneumatic or hand lever adjusted.

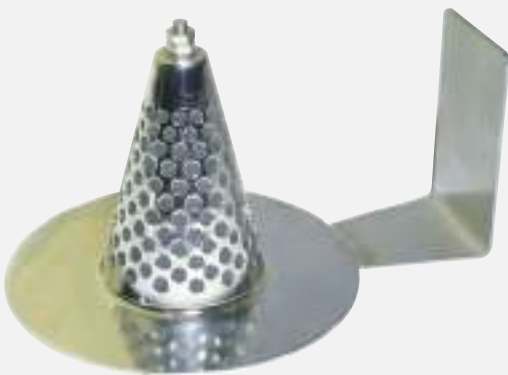

Non-return diaphragm

Part No. FT-001549 (50mm)
FT-005467 (80mm)
FT-005468 (100mm)
Ft-005469 (150mm)

Description

Stainless steel frame 2mm thick designed for insertion in pipework at any suitable point to act as a non-return valve.



80/100mm venturi units

Part No. DCM1201 - 80mm
DCM1222 - 100mm

Description

Various throat dimensions. Manufactured from solid aluminium. Manufactured to simulate the pressure at the underwing nozzle during the fuelling operation, thus giving a readily-accessible nozzle pressure reference for the fuelling pressure control system.



Pressure relief valve

Part No. FT-005470 Straight coupling
175 psi (3/4" thread)
FT-005471 tapered coupling
175 psi (3/4" thread)
FT-005472 straight coupling
150 psi (1" thread)

Description

- Solid brass construction.



Manually-operated ball valves

Part No. DB27425-1 100mm
DB27425-4 80mm
DB27425-7 50mm

Description

- Solid design and construction, made from aluminium with flanged connections
- Fitted with PTFE seats and seals
- 10 bar working pressure.



19 litre flow divider

Part No. FT-005476

Description

Monobloc unit in cast iron, complete with nickel-plated spools, enabling accurate hydraulic fuel control.



Pneumatically-operated ball valves

Part No. DB27425-2 100mm single action
DB27425-3 100mm dual action
DB27425-5 80mm single action
DB27425-6 dual action
DB27425-8 50mm single action
DB27425-9 dual action

Description

- Full-flow ball valves of solid design and construction, made from aluminium with flanged connections
- Fitted with PTFE seats and seals
- 10 Bar working pressure
- Single or dual-directional flow.



Fuel coalescers, filters and separators

Part No. Various (for example)

Description

- FT-005273** Coalescer element (6" dia x 43¼")
- FT-005276** Filter element (1¾" dia x 30¾")
- FT-005279** Separator cartridge (6" dia x 14½")
- FT-005473** Filter separator cartridge (6" dia x 10")



Air eliminator & relief valve

Part No. FT-005272

Description

Stainless steel construction and simple design to eliminate pivot wear, thus creating a friction-free medium-capacity air venting valve. 11 bar working pressure with a 1/8" orifice.



225 LPM portable aircraft/ helicopter fuelling pumpset

Part No. DC23215

Description

This unit is suitable for overwing/underwing refuelling of small fixed and rotary wing aircraft at flow rates of up to 225 lpm. Fuel can be drawn from either flexible tanks or drum stock. The pumpset is designed to be compact and portable by two men. The unit is engine-driven and incorporates a self-priming pump, filter water separator, bulkmeter and quick disconnect couplings for the attachment of suction and delivery hoses. Avgas or Jet options available.

Main components:

- Yanmar L40AE-D single cylinder, 4-stroke, air-cooled diesel engine equipped with a recoil rope starter and exhaust spark arrestor. With dual fuel capability, to run on Avgas.
- Close-coupled self-priming centrifugal product pump constructed in cast iron and equipped with a mechanical shaft seal. The pump has an integral self-balancing shaft reducing noise and vibration.
- Filter water separator to commercial or military specifications complete with air eliminator, sump drain/sample valve and piston type differential pressure gauge.
- Turbine flow meter accurate to $\pm 2\%$ equipped with a mechanical register with a resettable counter and non-resettable totaliser. With 4 digit display.
- Lever-operated suction isolating valve equipped with a 1½" male Kamlock type adaptor and drip cap.

Dimensions

Width	950mm
Depth	910mm
Height	770mm
Weight	165 Kgs (wet)
Weight	125 Kgs (dry)



Replacement shear spool frangible coupling

Part No. DBM11601

Description

Designed to be used with frangible coupling assembly *DCA11605*.



6mm hydraulic hose line and fittings

Part No. Various

Description

Stainless or mild steel pipe and fittings available.

- 6mm hose lengths up to 3m
- Straight connectors, equal T fittings, stud connectors, banjo connectors.



Frangible coupling assembly

Part No. DCA11605

Description

Designed as the weak point in a fuel pipeline breaking at the replaceable coupling *DBM11601*. Designed to break at the weak point irrespective as to the impact, thus ensuring no fuel leakage – fuel couplings are either side of the flange. Spring-operated to shut.



Manifold

Part No. FT-005280

Description

- 10mm manifold with 6 x 6mm outlets
- Full range of pneumatic fittings + 4mm, 6mm, 8mm, 10mm tube.

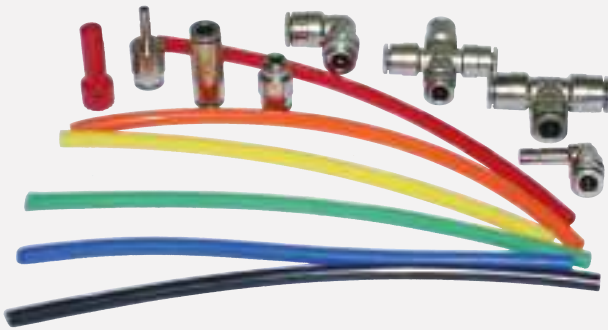

Pneumatic hose & fittings

Part No. Various

Description

- Available in seven colours – black, orange, red, yellow, blue, green or clear
- Five sizes, OD 4mm, 6mm, 8mm, 10mm, 12mm
- Fittings available for all eventualities in all dimensions, example depicted.



4" and 3" hydrant dispenser intake hose trolley kits

**Part Nos. DB3323-1 (4")
DB5770 (3")**

Description

Designed to give the intake hose generous ground clearance, reducing the risk of wear by minimising the likelihood of the hose scraping along the ground.

- The trolleys are supplied with two wheels as standard, but a four-wheel version is available if required
- Special mounting brackets to suit hydraulic storage rails are available for both
- Plated steel construction with synthetic rubber wheels.



100mm swivel castor

Part No. FT-005291

Description

- 100mm solid rubber wheel
- Steel frame ball bearing swivel assembly with 10mm bolt hole
- Overall height 125mm.



Pantograph assembly

Part No. DD26925

Description

- For refuelling from hydrants
- Typically for military applications
- Various lengths available
- Contact FTi for further details.

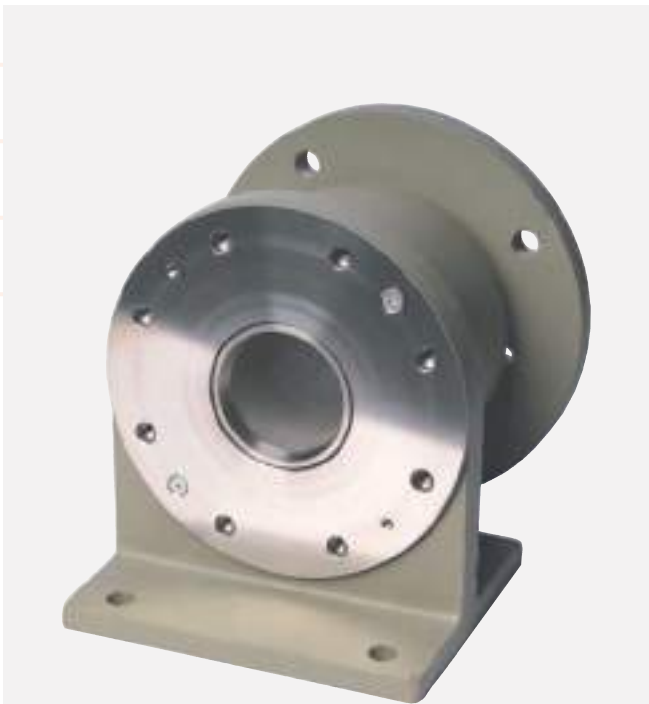

Hose reel swivel assembly

Part No. DC8915

Description:

- Solid design and construction
- Cast outer unit stainless steel
- Inner unit high-nitrile seals, ensuring long life and durability.



Easilift hydrant dispenser intake hose

Part No. DC3225

Description

Plated steel construction with PVC handgrip. Lightweight and simple construction for ease of use – reduces operator hose lift loads. Provides a 2.5:1 mechanical advantage.

The Easilift is a mechanical “over centre” device attached to the dispenser subframe and consisting of an actuating handle with a height-adjustable lifting hook and spring loaded safety latch. The actuating handle is at waist height for operational convenience.

Used in conjunction with the Fluid Transfer Hose Trolley Kit, Easilift is designed to make heavy hydrant dispenser intake hoses easy to lift/lower or stow, considerably reducing the likelihood of the vehicle operator suffering from back strain.

**FLUID
TRANSFER**
INTERNATIONAL

PIT BUDDY

FT-004053**Powered assisted lifter**Quality
Performance
Value for money

Many Global Oil companies and Into-plane operators are now issuing safety bulletins requiring fitment of pit lifters.

The latest generation of pit coupler lifter which not only protects operators from manual handling incidents but also conforms to the breakaway requirements of API 1584, 3rd edition. Robust, lightweight and competitively priced the Pit Buddy is emerging as the 1st choice for into-plane refuelling operators.

Contact us now for a quotation:**T: +44 (0)1453 833 381****E: sales@fluidtransfergroup.com****W: fluidtransfer.com**

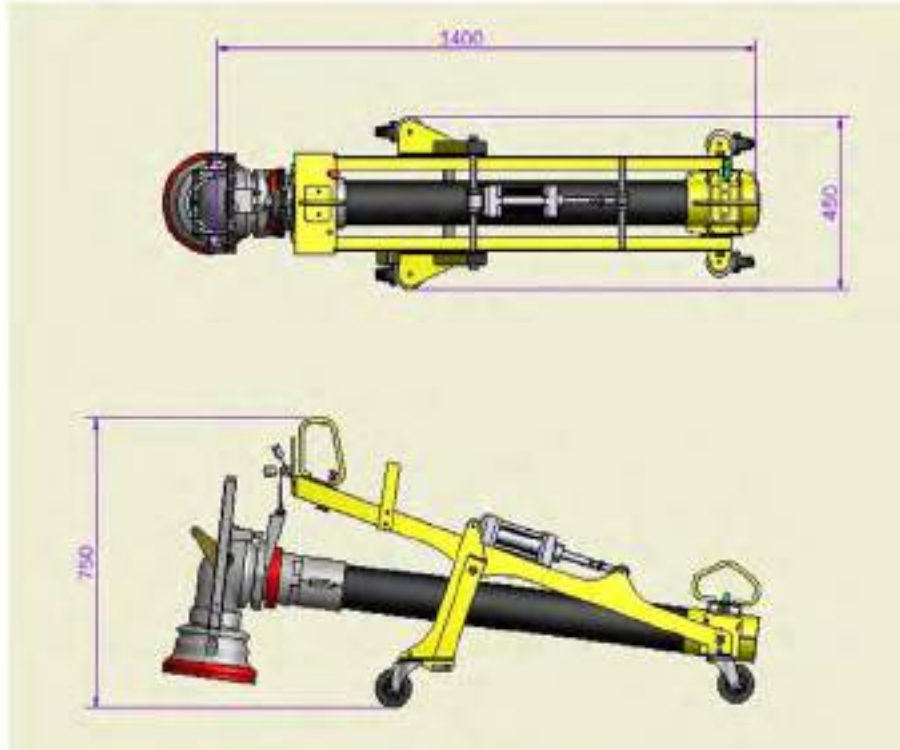

- Pneumatically assisted lifting mechanism.
- Maximum stability, maximum manoeuvrability.
- 1m of Floating hose to meet breakaway requirements.
- Field tested, proven and approved.
- Endorsed by Coupling manufacturers.
- Retro-fixable.
- The name “BUDDY” say’s it all.

You now have the alternative !

Contact us now for a competitive quotation or trial :

Phone +44 (0)1453 833 381

Email: sales@fluidtransfergroup.com fluidtransfer.com



Rear light guard

Part No. Various

Description

Helps to protect the rear light cluster from accidental damage. Bespoke to suit your light cluster/vehicle.



Pit valve lanyard reel

Description

Reel construction as *DCA12250*

Lanyard reels provide a physical connection between hydrant dispenser and pit valve. All cable includes a 20mm HD turnbuckle dog clip assembly.

<i>DC21675-1</i>	15m cable
<i>DC21675-2</i>	30m cable
<i>DC21675-3</i>	20m cable



Lanyard cable assemblies

Part No. DA4284-1/2/3

Description

Lanyard cable complete with 20mm HD turnbuckle dog clip assembly.

<i>DA4284-1</i>	15m cable
<i>DA4284-2</i>	30m cable
<i>DA4284-3</i>	20m cable



Mild steel plated clamp, MoD version

Part No. FT-005288



Self-adhesive and micro mat 1.6mm decals

Part No. DC10112/Various

Description

- Screen printed on 0.2mm thick self-adhesive vinyl material
- Ink is impervious to UV light and fuel spillage
- Micro mat decals are riveted or adhered in the desired location
- All decals available as bespoke items.



Earthing strip and weights

Part No. FT-005295

Description

- Two solid copper strips, encased in rubber
- Complete with stainless steel weights.
- Dimensions: 39mm W x 6mm D x 1800mm L to ensure the vehicle is constantly earthed.



Wheel chock

Part No. Various

Description

Mild steel plated and painted construction, solid plastic version available.



Gasket

Part No. DB0006

Description

1.6mm thick composite carbon fibre or Sentinel gasket material.



Nebar gasket material

Part No. Various

Description

- Brown Nebar sheet material for bespoke gasket requirements
- 1.5mm, 3mm or 4mm thick
- Sentinel sheet material also available in 2mm or 3mm thick sheets upon request.

FT-005296 3"
FT-005297 4"
NM005152 1.5"



Viton and high-nitrile O-ring seals

Part No. Various

Description

A full and comprehensive range of sizes always held in stock to suit production and customer requirements.



HIFR assembly

Part No. Various

Description

Fluid Transfer International has recently developed a 2" full bore HIFR assembly compliant with STANAG 3847, suitable for ship-to-helicopter refuelling.

The system offers an emergency airborne refuelling capacity which is simple to use and maintain.

Components

- Hose end pressure controller with cap fitted with 45 psi pressure regulator
- 3 metre length of non-collapsible hose
- Upper elbow manufactured in aluminium and fitted with a STANAG 3847 lifting eye
- Breakaway coupling
- Non-return valve
- 30 metre length of semi-lay-flat rubber hose
- Lower elbow manufactured in aluminium, fitted with a deck tie-down point
- ISO 45 dry-break deck connections and cap.



Pressure and vacuum vent valves

Part No. Various

Description

- Aerodynamic porting facilitates extremely high throughput
- Pressure: air flow at 21 kPa = 198,200 litres (7000 cu ft) per hour
- Vacuum: air flow at 7kPa = 99,100 litres (3500 cu ft) per hour
- Mandatory rollover seal-off as required by the UK Health & Safety executive included. This feature has proven its effectiveness many times.
- Viton seals are standard for compatibility with high-octane fuels
- Tough acetal polymer construction for durability
- Flame-retardant stainless steel gauze covers the inlet/outlet ports.

Available with various pressure and vacuum settings.

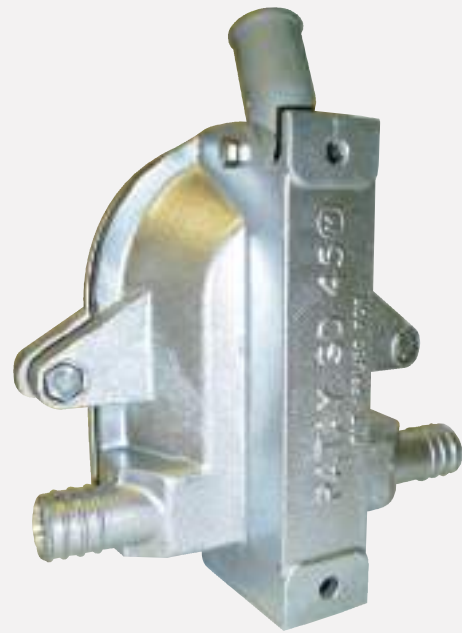

Patay hand pump – jet fuel

Part No. FT-005306

Description

An excellent product transfer pump ideally suited to tight spaces, due to its compact design and removable handle.

- Flat backed and coupled with a cranked rocker arm to facilitate direct mounting to any vertical surface
- A mounting bracket is available should base mounting be desired
- Capacity 45 litres per minute with a 4.5 metre head/lift
- To military specification
- 1" hose connections.



16" and 20" manhole covers

Part No. Various

Description

Internationally-accepted and specified by oil companies around the world to assist with the safe conveyance of petroleum-based products, the Emco Wheaton range of manhole covers offers unrivalled safety features and operational benefits.

- Pressure and vacuum vent fitted as standard
- Spring-loaded fill cap for emergency fire engulfment
- Automatic sealing in a rollover situation
- Two-stage opening.



Manhole cover key

Part No. F0053001

Description

The Emco Wheaton manhole cover key is used with all Emco Wheaton lockable, removable manhole covers. Removable, it is designed to ensure security to make sure that product pilferage is prevented.

- Hot brass forging for durability and finish
- Hole for securing key to cover if required
- One key fits all.

Order your key separately – they are not supplied with covers unless specified.



Black walkway safety walk

Part No. SK291-1

Description

Self adhesive slip-resistant walkway tape. 100mm wide by 18.25 metres long.



Dip guide tubes and dip mandrels

Part No. Various

Description

These products are designed to facilitate the easy, accurate measurement of a tank's contents. A mandrel with vented quick-release cap is used for quick access. With the F0293 a full-length gauged aluminium extruded tube is included to assist accurate measurement.

- Lightweight aluminium construction
- Durable 2.25mm tube to BS 1474 HE9M
- Safety provision includes a vented cap to release any pressure and prevent spray.



Tamper-proof covers

Part No. DA7969/DB22241/DB8376-1 and -2

Description

- Robust steel construction
- Brightly painted for increased visibility
- Allows control valves and override switch units to be set in assured positions.

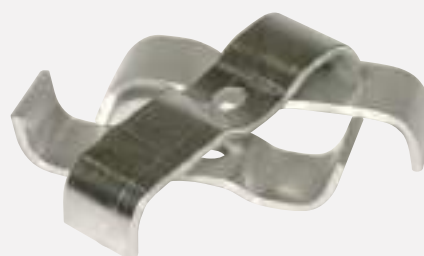

Walkway panel and walkway clips

Part Nos. Various

Description

- Heavy-duty aluminium design and construction
- Bespoke sizes, ensuring a perfect fit
- Secured by robust aluminium clips.



Fire Extinguisher storage box (red) Spill kit storage box (grey)

Part No. FT-005292
FT-005293

Description

Robust lightweight polyethylene construction with stainless steel hinges. Weatherproof seal and internally-sprung retaining bar.



Dry powder fire extinguishers BC

Part No. FT-005477 (2kg)
Ft-005478 (9kg)

Description

2kg/9kg dry powder fire extinguishers, featuring 2kg cab-fitted and 9kg chassis-fitted dry powder (sodium bicarbonate) non-toxic, functions by chemically reacting with the fire. Used on B and C class fires – petrol, oil, gas, paints, solvents, greases, electrical equipment and gaseous fires.



Spill kit

Part No. Various

Description

For general maintenance use, oil spills or chemical spills. These kits contain all the essential elements in the event of a spill.

Kit contains:

- 2 socks (3m x 8cm)
- 25 pads (heavyweight)
- 2 disposable bags
- 1 shoulder bag.

Fluid Transfer equipment is operated in the following countries:

Australia	Malaysia
Abu Dhabi	Mali
Bahrain	Malta
Belgium	Mauritius
Bangladesh	Mozambique
Brazil	Netherlands
Brunei	Nigeria
Burma	Norway
Canada	Oman
Caribbean	Pakistan
China	Philippines
Cyprus	Portugal
Denmark	Qatar
Djibouti	Ras al Khaimah
Dubai	Russian Federation
Egypt	Saudi Arabia
Ethiopia	Senegal
Fiji	Sierra Leone
France	Singapore
Gambia	South Africa
Ghana	South Korea
Greece	Spain
Guam	Sri Lanka
Guinea	Sudan
Hong Kong	Sweden
India	Switzerland
Indonesia	Tanzania
Italy	Tahiti
Ireland	Taiwan
Japan	Trinidad & Tobago
Kazakstan	Tunisia
Kenya	Uganda
Korea	Ukraine
Kuwait	United Arab Emirates
Laos	United Kingdom
Liberia	United States of America
Libya	Venezuela
Maldives	Vietnam

METEOR Hydrant Dispenser 3800 lpm



Features

Dimensions

Height: 2.60m +/- 50mm (excluding beacon)
Width: 2.85m (3,00m over hose trolley wheels)
Length: 7.90m

Flow Rate

3,800 LPM through 2 x deck hoses
1,000 LPM through 1 x reel hose

Filtration

Filter water monitor or filter water separator constructed in carbon steel with epoxy coat lining meeting the latest requirements of IP1583 and IP1581 respectively and is fitted with high differential pressure shutdown system.

Meter

Satam or Avery Hardoll positive displacement meter with Veeder Root EMR3 or Masterload II electronic display.

Hoses

Aviation hoses meeting EN1825 type 'C' Elaflex or Goodyear

Intake Hose Reel Hose Deck Hoses

Ø100mm x 10m long (Optional 3m extending boom)
Ø50mm x 20m long
Ø63mm x 3.5m long

Elevating platform

Hydraulically operated scissor mechanism platform with floor to ground height range from 1.5m to 4.2m. Platform equipped with raise/lower control and emergency lower control valve.

Intake Coupler

Ø100mm API coupler incorporating secondary pressure control sensed from either deck hose or reel hose fully compensating venturi's.

Hose End Equipment Controller (HEPC)

Hose end pressure control (HEPC) couplings equipped with 45psi regulator, vacuum breaker, 100mesh screen.

Safety Equipment

Fire extinguisher – 2 x 9kg BC dry powder fitting inside enclosed Container
2 x Bonding reels – manual rewind with 30m of clear PVC insulated copper cable
ATEX approved electrical barrier system.

METEOR Hydrant Dispenser 3800 lpm

Interlocks

Lanyard reel – manual rewind with 30m of red PVC coated stainless steel cable

FuelTronic© refuelling management system incorporating deadman timer and monitoring unit for up to 16 interlocks.

Brake interlock system preventing the vehicle from being moved if any item is left unstowed. Items protected are:

- Power take off engaged
- Stabiliser legs not fully raised
- Pit coupling not stowed
- Elevating platform not lowered
- Deck hose support pantograph not lowered
- Deck hoses not stowed
- Reel hose not stowed
- Bonding reels (x2) not stowed
- Lanyard reel not stowed

Pipework

Constructed in grade 304L schedule 5 and 10s seamed Stainless Steel tubing throughout.

Hosereel

Single pedestal mounted hosereel with double race ball bearings and hydraulic rewind

Dumptank

120L capacity fully draining tank with visual contents window and Low, high and high/high float switch system for automatic emptying and emergency cut off in event of overfilling

Options

Intake Coupler & HEPC

Choice of Avery Hardoll, Carter or Whittaker.

Pit Buddy

Pit coupling lifter, pneumatically assisted allowing break away of 3rd edition coupling meeting API 1584

Intake Hose

Retractable solid pipework extension giving an additional 3.0m length of intake hose.

Shock Alleviator

28L capacity bladder type

Chassis

Dispenser module can be mounted on a variety of manufacturers 4 x 2 chassis configurations with a payload capacity of 3,200kg, including full electric drive chassis.



Standard 10,000 Litre Capacity Aircraft Refueller



A 10,000L rigid refueller mounted on a 4x2 chassis. The refueller is equipped with 1 x underwing and 1 x overwing hose, single meter and filter water separator or an optional filter monitor. Options include a weatherproof cabinet. The refueller conforms to latest European Standards EN12312-5 and JIG1 Issue 11 requirements.

Features

Dimensions

Operating Temperature of -20°C to +50°C

Height: 3.20m +/- 50mm (excluding beacon)

Width: 2.50m

Length: 8.45m

Flowrate Fuelling

1,000 LPM through 1 x underwing reel hose

300 LPM through 1 x overwing reel hose

Defuelling Bottom loading

200 LPM through 1 x underwing hose

1,500 LPM

Fuel Pump

Gorman Rupp 03H1-GR Self-priming centrifugal pump (PTO driven)

Filtration

Filter water monitor or filter water separator constructed in carbon steel with epoxy coat lining meeting the latest requirements of IP1583 and IP1581 respectively, and is fitted with high differential pressure shutdown system.

Meters

Satam or Avery Hardoll positive displacement meter with Veeder Root EMR3 or Masterload II electronic display.

Hoses

Aviation hoses meeting EN1825 type 'C' Elaflex or Goodyear

Reel Hose Underwing Reel Hose Overwing

Ø50mm x 20m long

Ø38mm x 25m long

Hose End Pressure Controller (HEPC)

HEPC nozzle underwing, one Elaflex ZVF40 trigger nozzle overwing

Refueller Tank

10,000L usable capacity, constructed in aluminium alloy with 3% expansion allowance

One external Ø500mm manhole/lid with pressure vacuum vent with roll over safety valve and flame trap on vent valve

Internal Ø610mm access manholes

Single Ø254mm Bayham contents gauge

Calibrated dipstick in litres

Valance tank top to protect the handrails and man lid in the event of a roll over.

Standard 10,000 Litre Capacity Aircraft Refueller

Safety Systems

Rear access ladder, pneumatically actuated single-sided folding safety rail and non-slip walkway
Primary and secondary overfill prevention system

Fire extinguisher – 2 x 9kg BC dry powder fitting inside enclosed container
Bonding reel – manual rewind with 30m of clear PVC insulated copper cable
ATEX approved electrical barrier system

Interlocks

FuelTronic® refuelling management system incorporating deadman timer and monitoring unit for up to 16 interlocks.
Brake system preventing the vehicle from being moved if any item is left unstowed.

Items protected are:

- Product pump drive mechanism
- Reel hose HEPC and trigger nozzle stowage
- Bottom loading connections
- Outside source connection
- Bonding reel

An emergency interlock override system is provided

Pipework

Constructed in grade 304L schedule 5 and 10s seamed Stainless Steel tubing throughout.

Hosereels

Single volute pedestal mounted hosereels with double race maintenance free ball bearings and chain driven hydraulic rewind

Dumptank

60L capacity fully draining manually emptied tank with visual contents window and with high level float warning system

Options

HEPC

Choice of Avery Hardoll, Carter or Whittaker.

Chassis

Chassis manufacturer typically chosen from: MAN, Mercedes-Benz, Renault, or DAF, in 4x2 configuration
Other chassis manufacturers available by request



Standard 18,000 Litre Low Profile Aircraft Refueller



An 18,000 litre capacity rigid type refueller mounted on a 4x2 chassis cab. Suitable for towing a 45,000 litre capacity drawbar trailer the refueller is equipped with a rear mounted elevating platform with the main delivery and metering equipment located immediately behind the drivers cab. The refueller is constructed in accordance with current BS EN 12312-5 and JIG 1 issue 11 requirements where applicable.

Operating Temperature of -20°C to +50°C

Features

Dimensions

Height 2.85/2.90m +/- 50mm
Width 3.00m
Length 10.50/11.00m

Flow rate

Fuelling

Rear deck mounted hoses 3000 or 3400 lpm (63mm x 3.5m)
Reel hoses – 2 x 1100lpm (Choice of Underwing or Overwing)

Defuelling

Maximum 300 lpm through any hose

Bottom Loading

2500 lpm

Fuel Pump

Gorman Rupp inline self-priming centrifugal pump type 06D1-GHH

Filtration

Filter water monitor or filter water separator constructed in carbon steel with epoxy coat lining meeting the latest requirements of IP1583 and IP1581 respectively and is fitted with high differential pressure shutdown system.

Meters

Satam or Avery Hardoll positive displacement meter with Veeder Root EMR3 or Masterload II electronic display.

Hoses

- Reel Hose Underwing
- Reel Hose Overwing
- Deck Hoses

2-off Ø50mm bore x 20m long meeting the requirements of BS1825 Type C Elaflex or Goodyear.

2-off Ø63mm bore x 3.5m long type meeting the requirements of BS1825 Type C Elaflex or Goodyear.

Elevating platform

Hydraulically operated scissor mechanism platform with floor to ground height range from 1.5m to 4.2m. Platform equipped with raise/lower control and emergency lower control valve.

Access is via a fixed vertical ladder positioned at the rear.

Hose End Equipment Controller (HEPC)

Hose end pressure control couplings (HEPC) equipped with 45psi regulator, vacuum breaker, 100mesh screen.

Standard 18,000 Litre Low Profile Aircraft Refueller

Refueller Tank

18,000 litre usable capacity, constructed in aluminium alloy with 3% expansion allowance or Stainless Steel and equipped:

- 2-off Ø500mm recessed manlid assemblies c/w Pressure / vacuum vent valve, Ø250mm hinged inspection lids
- Calibrated captive type dipstick assembly
- Primary and secondary overfill systems
- Side mounted float actuated contents gauge
- Pneumatically actuated Ø150mm main footvalve
- Pneumatically actuated Ø80mm sump foot valve
- Pneumatically actuated Ø100mm bottom loading valve
- Tank top equipped with 3M's Anti slip walkway surface

Safety Systems

Fire extinguisher – 2 x 9kg BC dry powder fitting inside enclosed container
Bonding reels – manual rewind with 30m of clear PVC insulated copper cable

Lanyard reel – manual rewind with 30m of red PVC coated stainless steel cable

Interlocks

ATEX approved electrical barrier system

FuelTronic© refuelling management system incorporating deadman timer unit monitoring up to 16 interlocks.

Interlock override system.

Brake interlock system preventing the vehicle from being moved if any item is left unstowed. Items protected are:

- Product pump drive mechanism
- Reel hose HEPC stowage's
- Rear platform
- Platform mounted HEPC stowage's
- Bottom loading connections
- Outside source connection
- Bonding reel

Dumptank

60L capacity fully draining manually emptied tank with visual contents window and with high level float warning system.

Pipework

Constructed in grade 304L schedule 5 and 10s seamed Stainless Steel tubing throughout.

Hosereel

Fluid Transfer double volute heavy duty hosereels complete with hydraulic rewind mechanisms and hose guide rollers

Options

HEPC

Choice of Avery Hardoll, Carter or Whittaker

Chassis

Chassis manufacturer typically chosen from: MAN, Mercedes-Benz, Renault, or DAF, in either 4x2 or 6x2 format. Other chassis manufacturers available by request.



Standard 20,000 Litre Capacity Aircraft Refueller



A 20,000L rigid refueller mounted on either a 4x2 or 6x2 chassis. The refueller is equipped with 1 x underwing and 1 x overwing hose, single meter and filter water separator or an optional filter monitor. Options include a weatherproof cabinet. The refueller conforms to latest European Standards EN12312-5 and JIG1 Issue 11 requirements.

Operational Temperature of -20°C to +50°C

Features

Dimensions

Height: 3.20m +/- 50mm (excluding beacon)
Width: 2.80m
Length: 9.65m

Flowrate Fuelling

1,000LPM through 1 x underwing reel hose
300LPM through 1 x overwing reel hose

Defuelling Bottom loading

200LPM through 1 x underwing hose
1,500LPM

Fuel Pump

Gorman Rupp 03H1-GR Self-priming centrifugal pump (PTO driven)

Filtration

Filter water monitor or filter water separator constructed in carbon steel with epoxy coat lining meeting the latest requirements of IP1583 and IP1581 respectively and is fitted with high differential pressure shutdown system.

Meters

Satam or Avery Hardoll positive displacement meter with Veeder Root EMR3 or Masterload II electronic display.

Hoses

Aviation hoses meeting EN1825 type 'C' Elaflex or Goodyear.

Reel Hose Underwing Reel Hose Overwing

Ø50mm x 20m long
Ø38mm x 25m long

Hose End Pressure Controller (HEPC)

HEPC nozzle underwing, one Elaflex ZVF40 trigger nozzle overwing

Refueller Tank

20,000L usable capacity, constructed in aluminium alloy with 3% expansion allowance. Two external Ø500mm manhole/lid with pressure vacuum vent with roll over safety valve and flame trap on vent valve
Internal Ø610mm access manholes
Single Ø254mm Bayham contents gauge
Calibrated dipstick in litres
Valenced tank top to protect the handrails and manlids in the event of a roll over

Standard 20,000 Litre Capacity Aircraft Refueller

Safety Systems

Rear access ladder, pneumatically actuated single-sided folding safety rail and non-slip walkway
Primary and secondary overflow prevention system

Fire extinguisher – 2 x 9kg BC dry powder fitting inside enclosed container
Bonding reel – manual rewind with 30m of clear PVC insulated copper cable
ATEX approved electrical barrier system

Interlocks

FuelTronic® refuelling management system incorporating deadman timer and monitoring unit for up to 16 interlocks.
Brake system preventing the vehicle from being moved if any item is left unstowed

Items protected are:

- Product pump drive mechanism
- Reel hose HEPC and trigger nozzle stowage
- Bottom loading connections
- Outside source connection
- Bonding reel

An emergency interlock override system is provided

Pipework

Constructed in grade 304L schedule 5 and 10s seamed Stainless Steel tubing throughout.

Hosereels

Single volute pedestal mounted hosereels with double race maintenance free ball bearings and chain driven hydraulic rewind

Dumptank

60L capacity fully draining manually emptied tank with visual contents window and with a high level float warning system

Options

HEPC

Choice of Avery Hardoll, Carter or Whittaker.

Chassis

Chassis manufacturer typically chosen from: MAN, Mercedes-Benz, Renault, or DAF, in either 4x2 or 6x2 format
Other chassis manufacturers available by request



Standard 40,000 Litre Capacity Aircraft Refueller



A semi-articulated refueller incorporating a 4x2 chassis and single trailer axle configuration for optimal manoeuvres on the airport ramp. The elevating platform and refuelling unit are mounted on the chassis unit immediately behind the cab, with the semi-trailer tank attached by means of a liquid 5th wheel. The refueller is designed and constructed in accordance with the latest European Standards BS EN 12312-5 and JIG 1 Issue 11 requirements where applicable.

Operating Temperature of -20°C to +50°C

Features

Dimensions

Height: 2.90m +/- 50mm (excluding beacon)
Width: 3.00m
Length: 17.00m

Flowrate

Fuelling

2,850 LPM through 2 x deck hoses
1,000 LPM through 1 x reel hose

Defuelling

300LPM through 1 x overwing reel hose
300LPM through 2 x deck hoses or reel hoses
100LPM through 1 x overwing hose

Bottom Loading

2,500LPM

Fuel Pump

Gorman Rupp 06D1 GAR Self-priming centrifugal pump (PTO driven)

Filtration

Filter water monitor or filter water separator constructed in carbon steel with epoxy coat lining meeting the latest requirements of IP1583 and IP1581 respectively and is fitted with high differential pressure shutdown system.

Meters

Satam or Avery Hardoll positive displacement meter with Veeder Root EMR3 or Masterload II electronic display.
Flowrate up to 3000LPM for deck hoses
Flowrates up to 300/1,000LPM (separately) for reel hoses

Hoses

Aviation hoses meeting EN1825 type 'C' Elaflex or Goodyear

Reel Hose Underwing Reel Hose Overwing Deck Hoses

Ø50mm x 20m long
Ø38mm x 25m long
Ø63mm x 3.5m long

Elevating platform

Hydraulically operated scissor mechanism platform front mounted with floor to ground height range from 1.5m to 4.2m. Platform equipped with raise/lower control and emergency lower control valve

Hose End Equipment Controller (HEPC) Liquid 5th Wheel

Hose end pressure control (HEPC) couplings equipped with 45psi regulator, vacuum breaker, 100mesh screen.
Fuel transfer from the refueller tank to the suction side of the pump is through a liquid 5th wheel assembly incorporating a Ø150mm swivel.

Standard 40,000 Litre Capacity Aircraft Refueller



Refueller Tank

The mechanical connection to the chassis unit is via a Ø1000mm turntable.
40,000L useable capacity constructed in aluminium alloy with 3% expansion allowance.
Three external Ø500mm manholes/lids with pressure vacuum vents with Roll over safety valve and flame traps on vent valves
Internal Ø610mm access manholes
Single Ø254mm Bayham gauge
Calibrated dipstick
Two jacking points
Valenced tank top to protect the handrails and manlids in the event of a roll over.

Safety Systems

Rear access ladder, pneumatically actuated single-sided folding safety rail and non-slip walkway
Bottom loading system overspill prevention system fitted, with secondary safety cut out.
Fire extinguisher – 2 x 9kg BC dry powder fitted inside enclosed containers
Bonding reel – manual rewind with 30m of clear PVC insulated copper cable
Lanyard reel – manual rewind with 30m of red PVC coated stainless steel cable

Interlocks

ATEX approved electrical barrier system.
FuelTronic® refuelling management system incorporating deadman timer and monitoring unit for up to 16 interlocks.
Interlock override system
Brake interlock system preventing the vehicle from being moved if any item is left unstowed. Items protected are:

- Product pump drive mechanism
- Reel hose HEPC stowage's
- Bottom loading connections
- Outside source connection
- Bonding reel

Pipework

Constructed in grade 304L schedule 5 and 10s seamed Stainless Steel tubing throughout.

Hosereel

Single pedestal mounted hosereel with double race ball bearing internals and hydraulic rewind.

Dumptank

60L capacity fully draining tank with visual contents window and high level float switch system for manual emptying and emergency fuel system cut off in the event of overfilling. Manual emptying as standard.

Options

HEPC

Choice of Avery Hardoll, Carter or Whittaker.

Chassis

Chassis manufacturer typically chosen from: MAN, Mercedes-Benz, Volvo, Renault, or DAF, in either 4x2 or 6x4 format. Other chassis manufacturers available by request.



Standard 10,000 Litre Capacity Pit Flusher



10,000L hydrant pit cleaner suitable to perform the following operations: routine flushing of hydrant pit valves, routine sampling from hydrant low point drains and purging high point vents, cleaning of hydrant pits with air, water and removal of dirt and water with vacuum suction.

Features

Dimensions

Height: 3,250mm
Width: 2,850mm
Length: 10,250mm

Hydrant Pit Flushing System

Ø100mm inlet hose fitted with heavy duty castors and a Carter intake coupler
Hydraulically operated stowage beam position around the vehicle
Deadman provided to actuate the opening and closing of the pit valve
The deadman is incorporated with high level shutoff device
A basket type strainer with drain valve dust cap to be installed before tank entry

Low Point Sampling

A low point sampling system is connected directly into the flushing tank with non return valve and tank filling is protected by high level shutoff system during the sampling

Pit Cleaning Tanks

Two stainless steel tanks with 500L and 100L capacity for water and detergent respectively are fitted

Detergent Cleaning System

The jetting pump is capable of producing 140 bar of pressure for cleaning of pits. Pump is linked to the water and detergent tanks so that detergent and water can be used simultaneously or independently
A spring rewind hose reel with 20m of Ø12.5mm hose is attached to a trigger operated lance, 1.0m in length

Slop Tank and Vacuum System

A 1000L stainless steel slop tank for recovery of slops, equipped with over-fill protection, contents gauge, suitable access point with lid for inspection and cleaning and drain valve with dust cap
A hydraulically operated diaphragm vacuum pump for suction of foreign material, water/water detergent mixer etc from hydrant pit is fitted
A hydraulically operated hose reel with 20m of Ø25mm hose with a 1.0m long lance

Air Drying System

A spring rewind hose reel with 20m of Ø12.5mm hose with 1.0m long trigger operated lance fitted for high pressure drying air

Operating Station

Roller shutter that covers all operating controls and hoses
Located at the operating panel are all operative valves and levers, deadman control handle switch and connection, engine stop, emergency fuel stop, hydrant inlet pressure gauge, air reference pressure gauge for

FT-009399

**Compliant to
JIG bulletin
No. 58**



This differential pressure shut down safety system is designed to comply with JIG bulletin No. 58 of January 2013. This states that a differential pressure switch must now be fitted to all filter monitors and is also recommended for all filter water separators in order to automatically cut off fuelling once the differential pressure reaches a critical level, preventing any possibility of contaminated fuel passing onto an aircraft. The critical differential pressure can be adjusted from manufacture to suit either filter water separator (15 psi) or filter water monitor (22 psi) installations, or indeed any chosen differential pressure between 3 and 58 psi. The Fluid Transfer differential pressure shut down system has been designed to be easily and safely retrofitted to all vehicles. The all pneumatic design is “fail safe”, and with no electrical components avoids ATEX compliance issues. Installation is simply achieved on refuelling vehicles (of any manufacturer) by tapping into the Ø6mm high and low pressure supply lines to the existing differential pressure gauge. The control box containing the visual detectors, test system and key switches, together with the differential pressure switch, can be mounted to the existing instrument panel or an alternative suitable location.

Features

Operation

A pneumatic output is produced by the pressure switch when the critical differential pressure of 22 psi is reached. This pneumatic output disables the deadman system via a pneumatic pilot valve in order to cut off the fuel supply at the pit coupler on a hydrant dispenser or at the in-line pressure control valve on a refueller.

Pneumatic indicators display on the control unit which of the 3 states the system is currently in:

- High differential pressure system activated
- High differential pressure system reset
- High differential pressure system override

Deflection testing

Full scale deflection testing on the differential pressure gauge is possible by utilising the switch's override option.

Safety features

Reset and override functions are only accessible with a safety key in order to comply with the JIG bulletin which states that the fuelling operator must not be able to override the system.

Construction

The controls and indicators are housed in a 200x160x100mm polycarbonate enclosure. Pneumatic connections into and out of the control box are via Ø6mm push fit couplings.

Fitting

The differential pressure switch is piped between the high and low

Filter High Differential Pressure Shut Down System

FT-009399

pressure Ø6mm gauge lines to the existing differential pressure gauge.
Fits easily to Ø6mm stainless steel gauge lines.
Universal fitting kit can be supplied if required – FT-009576.

Advantages of pneumatic system

The vehicle's existing differential pressure gauge is retained.
No complicated electrical or PLC based installation required, allowing straightforward installation by workshop personnel familiar with simple pneumatics.
No additional electrical pressure transducers required.
No requirements for additional electrical parts and no impact on existing ATEX approvals.

Contents

- Control box module
- Differential pressure switch
- Pilot valve
- Regulator
- Gauge 0-10 Bar
- Control box mounting bracket

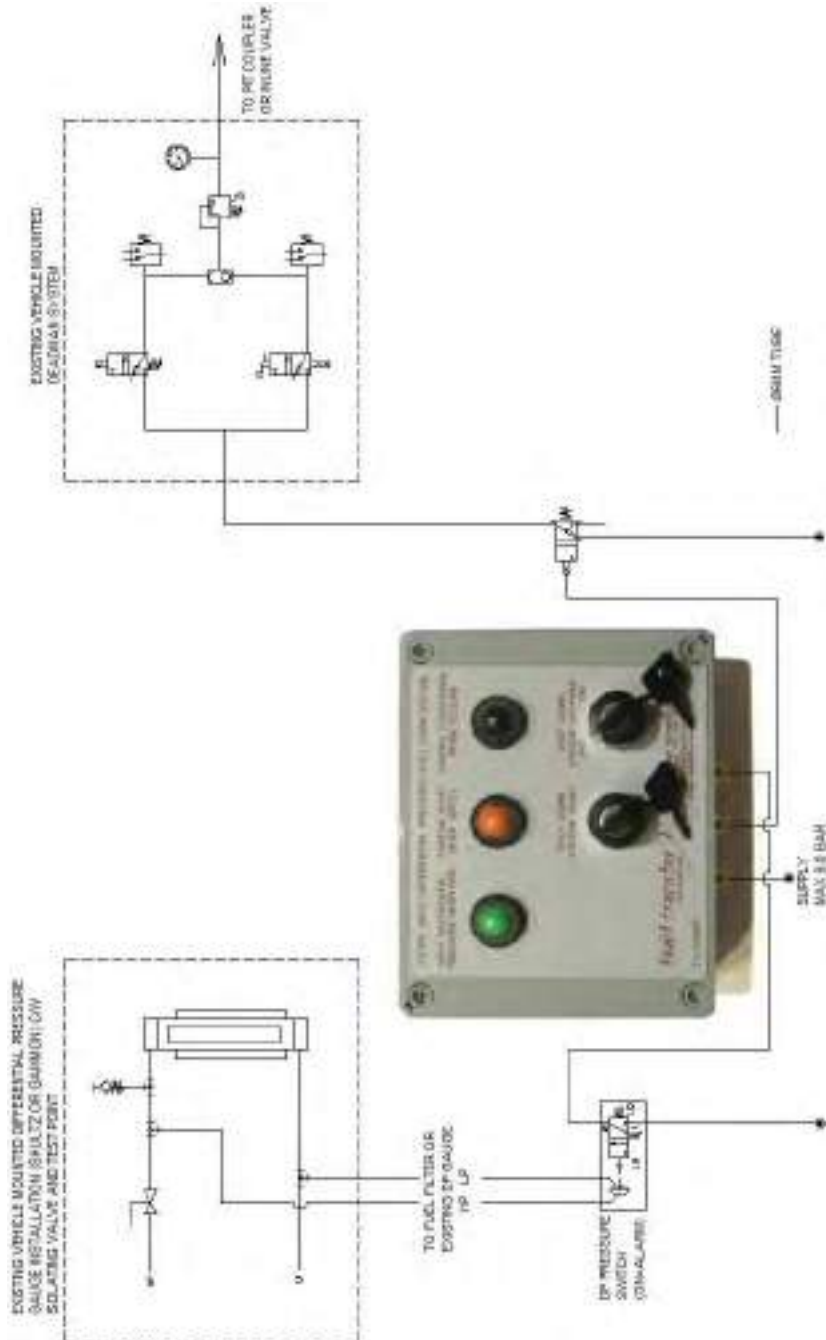

Pantograph Assembly 3"

DD26925



The Fluid Transfer pantograph assembly comprises three 5m articulated section of Ø80mm (Ø3") nominal bore stainless steel pipework. The inlet is by means of a vertical flanged connection – 3" ASA 150 raised face. The outlet swan-neck is 2 1/2" NPT and connects via an Emergency Dry-Break Coupling to a 2 1/2" fuelling hose of 3 metres in length.

Connection to the aircraft is via a Carter fuelling nozzle which conforms to all the relevant specifications.

Articulation of each boom section is by means of an 80mm Fluid Transfer stainless steel swivel with slim profile ball races and self energising P.T.F.E. lip seals for long reliable service life.

Terrain-following is achieved by means of flexible joints utilizing hinged restraints and pivoted castor assemblies. Castors are 6" diameter (polyurethane tyred for wear and fuel resistance). The pair of castors nearest the hose end of the boom are fitted with foot brakes. All castors incorporate swivel seals and greaseable roller bearings.

The boom folds to a stored width of approximately 600mm.

Features

Pipework and Fittings

80mm nominal bore schedule 10 stainless steel – TIG welded

Swivels

80mm stainless type DC1233

Flexible joints

80mm Elaflex type ERV

Castors

Heavy duty Ø150mm castor

Hose

Goodyear aviation type HCD, 63mm nominal bore x 3m long with tinned Spannoic end fittings

Nozzle

Carter 61428 CF46H
A tray is attached to the boom to provide stowage for the hose and nozzle when not in use

Testing

Pipework assembly including swivels and flexible joints hydrostatically pressure tested to 15.5 bar (225psi)

Finish

Metal parts primed with a zinc rich primer and finished in light grey top coat to RAL7035, finish colour by request

ATEX LED Spot Lamp

FT-009734



Operation

The Fluid Transfer ATEX zone 1 approved Ex-d spot lamp has been specifically designed for use on mobile fuelling applications. This LED lamp contains 3 super-bright LEDs which produce a crisp white light with an 11° beam angle.

A ball joint mount allows the lamp to be fixed in a multitude of positions. It is locked into position by hand using a single lever. This provides optimal manoeuvrability, and also allows great ease of use as no tools are required to adjust the lamp positioning.

Power

The power of the LED light is equivalent to that of a 50W halogen lamp.

Lifespan of LEDs

The LEDs should last for no less than 50,000 hours.

Electrical Properties

The lamp is operated between 12V-30V DC and at 400mA. M20 standard gland fitting.

Heat Properties

Low power consumption means low heat dissipation, allowing the lamp to remain cool to touch.

Construction

Robust aluminium construction with a durable powder coat white finish.





Applications

Air-powered Pressure Test Pump for in-situ testing of fuelling hose integrity to JIG/API standard periodic testing requirements.

Features

- Lightweight and portable
- Air powered
- Dry-break connections
- No need to drain /remove hoses
- Rated for testing up to 24bar (350 psi)

Options

- 300 psi test pressure version
- 600 psi test pressure version



Specification

The Fluid Transfer Air Powered Hose Pressure Test Pump is designed for 'in-situ' pressure testing of aircraft refuelling vehicle delivery hoses and vehicle pipework. It can be used safely in hazardous areas to test vehicles with standard 63mm (2¹/₂") underwing refuelling nozzles.

An air-driven hydraulic piston pump is fed from an outside compressed air supply source via an adjustable air pressure regulator and filter. Fuel is pumped through a wire reinforced hose to an adapter (Hose End Pressure Test Coupling DBA10605) which connects to the 63mm (2¹/₂") underwing refuelling Hose End Pressure Control nozzle fitted to the end of an aircraft refuelling hose.

Just three actions are required to operate the pump.

- Connect a filtered, compressed air supply not exceeding 7bar (100psi) to the pump.
- Top up the filtered low-pressure fluid supply to the inlet valve from the tank.
- Connect the high-pressure PTFE steel braided hose, (to the Hose Pressure Test Coupling) to the test hose.



Hose Pressure Test Pump (Air-Powered)

Part No DC8932

Technical Data

Mounted in a tubular steel carrying frame the pump consists of an air driven hydraulic pump, which draws fuel from a 20 litre capacity reservoir via a gauze suction strainer. Fuel is pumped through a reinforced hose to an adapter connected to the 63mm (2 $\frac{1}{2}$ ") underwing refuelling nozzle fitted to the end of an aircraft refuelling hose.

The air-driven hydraulic pump is fed from an outside air pressure supply source via an adjustable air pressure regulator/ filter and fitted with a pressure gauge. The hydraulic pump is capable of delivering 40bar (600 psi), but the rated test pressure is restricted to 20bar (300 psi) when testing the hoses using the Pressure Test Coupling DBA10605.

The outlet side of the pump is fitted with a calibrated pressure gauge and an isolating valve, which is set closed when the correct test pressure is reached. A pressure release valve releases the 'locked in' pressure into the reservoir once the pressure test has been completed.

The inlet to the air pressure regulator terminates in a quick disconnect coupling (both halves of the coupling are provided). The removable female half coupling is fitted with a hose tail for connection to a suitable 6mm (1/4") bore air supply hose. The fuel reservoir has a hinged fill cap and drain valve.

Just three connections are required to operate the pump.

- A filtered air supply not exceeding 7 bar (100psi) to the pump via the air filter-regulating valve ①.
Note: Under no circumstances must the applied air pressure be allowed to exceed 7.0bar (100 psi).
- A filtered fuel supply to the inlet valve ② from the tank.
A positive head of fluid is recommended for maximum performance.
- The high-pressure tube to the outlet valve ③ from the Hose Pressure Test Coupling DBA10605.

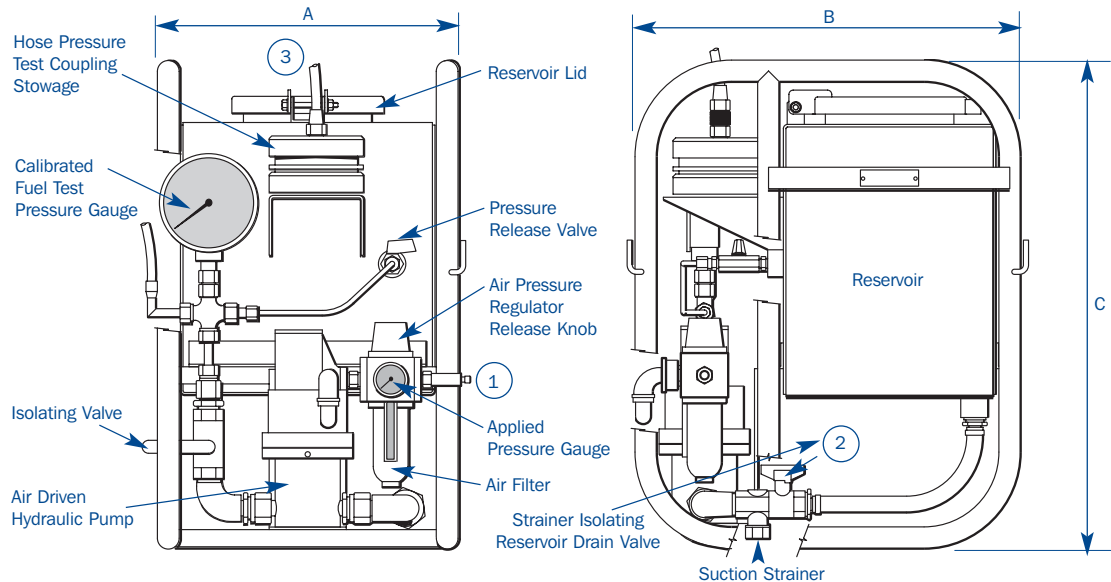

Part No.	Item	Options
DC8932	Pressure Test Pump 300 Psi Rating	Standard
DC8932-HP	Pressure Test Pump 600 Psi Rating	Option
DBA 10605	Hose Pressure Test Coupling	Option
UCA/2-YYB	Hydraulic Seal Kit	Option
UC/1-YYY	Pneumatic Seal Kit	Option

Dimensions.

Item	A	B	C	Weight (dry)
Dimensions (mm)	500	400	570	23kg

Maintenance

After each use - Remove the air filter bowl and wipe away any moisture or water.

12 Monthly

- Remove air filter bowl and wash air filter element in clean jet fuel
- Clean thoroughly with compressed air jet and replace.
- Drain reservoir and withdraw strainer element. Wash thoroughly in clean jet fuel and replace.
- Re-fill reservoir within approximately 50mm of the top with clean jet fuel.

FTI's policy of continuous improvement means we reserve the right to alter designs and specifications without notice.

The descriptions, illustrations and product references in the datasheet are for information purposes only and are not binding. (updated August 07)



Applications

Adapter permitting connection with Hose End Pressure Controllers to allow in-situ testing of hoses, used in conjunction with Air-Powered Pressure Test Pump DC8932.

Sizes

Standard profile 3-point bayonet adapter to suit all proprietary Hose End Pressure Control nozzles. Eg. Avery, Hardoll, Carter, Whittaker etc.

Features

- Aluminium body with scalloped hand grip
- Brass NATO standard adapter
- 1/4" BSP test pump connection tapping

Options

Used in conjunction with Fluid Transfer Air-Powered Pressure Test Pump DC8932, see separate data sheet.



Specification

The Fluid Transfer Hose Pressure Test Coupling is designed to permit in-situ pressure testing of aviation refuelling delivery hoses fitted with underwing pressure refuelling nozzles.

Used in conjunction with the Fluid Transfer Air Powered Pressure Test Pump DC8932 or similar, the required test pressure can be applied to the test hose via a tapping in the body of the coupling. To undertake pressure testing, the Coupling is connected to the hose end nozzle, the delivery hose flow control valve is closed and the nozzle poppet opened.

The Pressure Test Coupling can also be used in conjunction with underwing pressure refuelling nozzles, which are fitted with integral spring set pressure regulating/surge controllers. These regulators are fitted with small non-return valves, which allow high downstream pressure to bleed upstream in the hose as the upstream pressure decays.



Hose Pressure Test Coupling

Part No DBA10605

Technical Data

The body of the Fluid Transfer Hose Pressure Test Coupling is finished in aluminium alloy. A 1/4" BSPPF tapping is provided for connection to the external test pressure source. A 3-point standard NATO Bayonet adapter made in brass is sealed to the body with flush countersunk hexagon socket screws.

The Coupling is designed for use with all proprietary Hose End Pressure Control nozzles (Eg. Avery, Hardoll, Carter, Whittaker etc). The body of the Coupling allows sufficient room for both models of poppet profile in their open position.

During testing any relevant sensing line isolating valves, depressurising valves etc which may be connected to the circuit must be closed. Approximately 100ml of fuel is released during disconnection and provision should be made to suitably contain it. Hole 'F' is provided for a lever to be inserted to release the coupling should pressure have locked the coupling to the Hose End Pressure Controller.

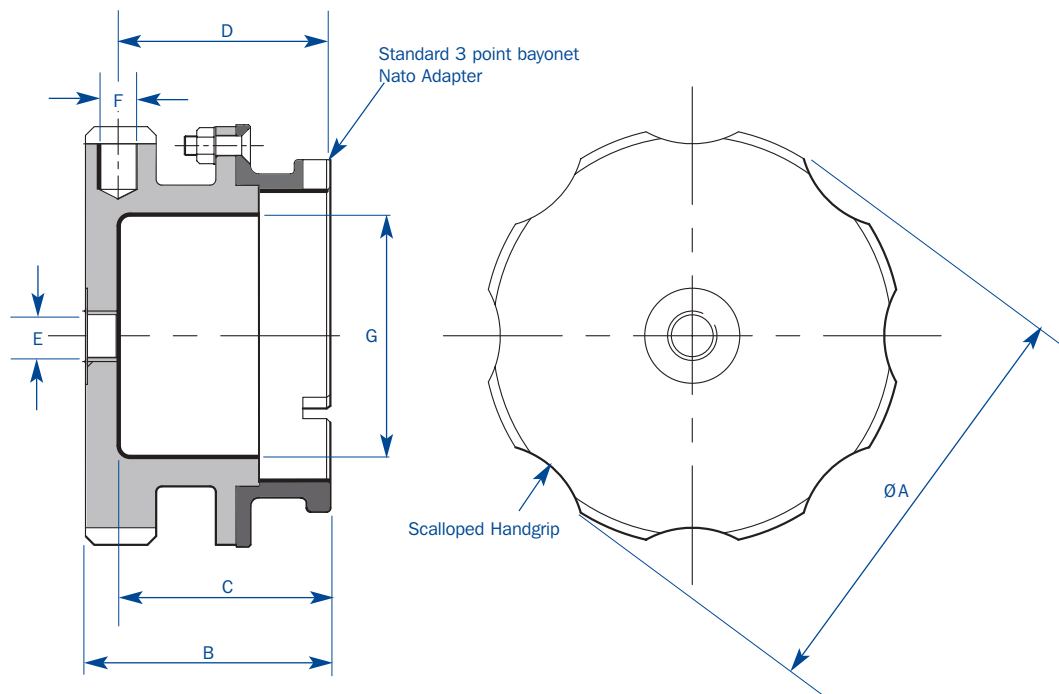

Dimensions

The Fluid Transfer Hose Pressure Test Coupling dimensions are as follows:

Part No	Item	A	B	C	D	E	F	G	Weight
DBA10605	Hose Pressure Test Coupling	Ø110	70.3	61.5	61.7	Ø1/4"BSP	Ø10	Ø76.3	0.9kg

Dimensions in (mm)





Applications

“Release - to - close” handswitch that controls the flow of product enabling the operator to react quickly to any incident and terminate fuel flow.

Features

- Stainless Steel Lever.
- Fuel resistant switch housing.
- Operating temperature range minus 40°C to 105°C.
- Max voltage 100 Vdc.
- Max switching current 0.25 Amps.
- Enclosure protection to IP67.
- Shock rating to 100G.



Specification

The FLUID TRANSFER 11101 Deadman Handswitch has been designed specifically to meet the stringent requirements of mobile and fixed aircraft refuelling systems. The handswitch is of rugged and extremely lightweight construction and the design concept has proved to be the industry standard to refuelling personnel in locations worldwide. The handswitch embodies features which overcome some of the inherent weaknesses of existing designs in order to improve reliability and serviceability.

The Fluid Transfer Deadman Handswitch provides the operator with the means to terminate product flow in an instant, by simply actuating a lever the operator is able to control refuelling.

Deadman Handswitch

Part No DAA11101/DAA11115/DAA11117

Technical Data

The Deadman Handswitch uses a shock resistant sensor where the switching means is housed in a resiliently mounted compact, easily removable element. The construction of the Handswitch provides for effective water vapour proofing and efficient cable strain relief. Positive retention of the permanent magnet is provided for on the stainless steel actuating lever. The lever is attached to the main switch housing by a stainless steel pivot pin designed to withstand the rigours of a typical operational environment. The lever is gripped to "make" the switch and released to "break" it. Cable termination is via a standard 2-way screw type terminal block located in the rear end of the switch housing.

The Deadman Handswitch incorporates the following features as standard.

- Operating temperature range -40°C to 105°C
- Cable gland accept wire sheaths between 5mm and 10 mm in diameter
- Maximum voltage rating 100Vdc
- **Maximum switching current 0.25A**
- Contacts are normally open, 3 watt rating.
- Switching element is hermetically sealed and potted.
- Enclosure protection to IP67.
- Shock rating to 100G.

- 1 Low hysteresis 'Alcomax' permanent magnet
- 2 Fuel Resistant switch housing
- 3 Stainless steel pivot pin
- 4 Cable terminal block
- 5 End cap
- 6 Gland nut
- 7 Cable gland
- 8 "O" Ring
- 9 Shock resistant sensor
- 10 Stainless steel actuating lever
- 11 "O" Ring

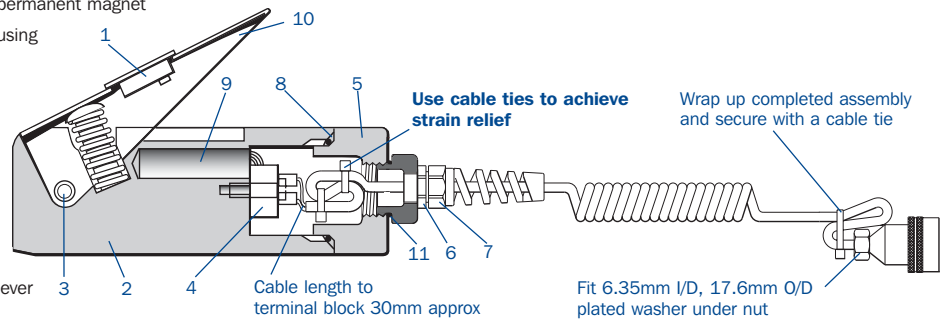

The Deadman Handswitch assembly is offered in a variety of configurations, giving the customer the flexibility to match the product to individual applications. Below is the range of standard options.

All cables are coiled 'Suzie'® as standard. Straight cables can be offered on request. 3 core cable can be supplied for special applications.

Part No	Cable length	End Plug
DAA11101	Handswitch only	None
DAA11115-1	10 m	N600
DAA11115-2	14 m	N600
DAA11115-3	18 m	N600
DAA11117-1	10 m	Not Fitted
DAA11117-2	14 m	Not Fitted
DAA11117-3	18 m	Not Fitted
DAA11117-5	3 m	Not Fitted

Fitting a cable to the Handswitch:

1. Remove the end cap and cable gland by unscrewing the cap in an anti-clockwise direction.
2. Pass the sheathed cable through the cable gland and end cap but do not tighten the gland nut.
3. Cut the cable sheath back by approx. 40 mm and bare the ends for connection to the terminal block.
4. When used in conjunction with the FLUID TRANSFER type DA1418-2 coiled 'Suzie' cable, use two cable ties to knot the cable thereby providing effective strain relief - see sketch above.
5. Carefully unscrew the terminal block and withdraw the switch/sensor assembly together with the terminal block from the switch housing.
6. Connect the cable to the terminal block and re-fit the switch/sensor and terminal block into the switch housing. Tighten the fixing screw.
7. While preventing the cable from rotating relative to the switch housing, tighten the end cap sufficiently to prevent it being unscrewed by hand (ensure that the 'O' ring is fitted).
8. Tighten the gland nut on to the cable gland.
9. Check the switch for correct operation.

NOTE: On subsequent dismantling, always release the gland nut prior to unscrewing the end cap and ensure that cable does not rotate relative to the switch housing when the end cap is being unscrewed.

As with any electrical switch in a hazardous application it has to offer protection against a possible electrical spark. In this respect the 11101 series handswitch is designed for and must be used in conjunction with a current limiting relay such as the Fluid Transfer 1859 series (12 volt) or 1860 series (24 volt) current limiting relays or the 10826 series (12-28 volt) deadman timer system. These devices limit the switching current to an intrinsically safe level of 50 milli-amps. If it is installed or tested in higher voltage or current applications the reed switch contacts will be welded together and warranty claims will not be accepted.

FTI's policy of continuous improvement means we reserve the right to alter designs and specifications without notice.

The descriptions, illustrations and product references in the datasheet are for information purposes only and are not binding. (updated August 07)



Applications

Prevents the illicit overriding of the deadman handswitch thus preventing the operator from wandering off or becoming distracted.

Size Available

172mm x 136mm x 85mm

Features

- Supply 12 - 28 Volts.
- Can be linked to Vapour Proof Lamp (option) to provide visual prompt.
- Can be linked to Audible Sounder (option) to provide audible prompt.



Specification

The Fluid Transfer Deadman Timer System is a unique system that considerably enhances the effectiveness of existing electrical deadman systems and therefore provides extra safety assurances to the airlines. The Timer system is designed to deter the illicit overriding of an existing safety device - the remotely held deadman handswitch.

A switch is incorporated within deadman handswitches which controls the flow of product. When the handswitch is released a control circuit is broken and product stops flowing. The operator therefore is able to react quickly to any incident and terminate flow.

Unfortunately the design of deadman handswitches makes them very easy to override e.g. an elastic band is often used or they can be wedged between pipework. The operator is then at liberty to wander off or become distracted. He has then lost effective control of the fuelling operation.

The Fluid Transfer Deadman Timer System ensures the operator has effective control by demanding a positive input from the operator during fuelling operations. This is achieved by means of a timer circuit that is designed to "time-out" every 2.5 -3 minutes. Flow is stopped after this period unless the operator generates a reset signal by releasing and regripping the handswitch.

The timer system is very compact and is mounted within an electrical enclosure for fitting in an electrically safe area. This is usually the vehicle cab and due to the small lightweight design of the unit this is possible in any vehicle.

The system is very easily installed on new vehicles. All deadman system connections are routed to and from the board-mounted Timer System connecting block i.e. a fused supply, air solenoid wiring, deadman handswitch wiring, audible and visual prompt wiring.



Deadman Timer System for Refuelling Vehicles

Part No DBA10826

Technical Data

The Fluid Transfer Deadman Timer System takes over the switching of the pneumatic solenoid valve which in turn controls the deadman valve. A low-current handswitch feed (approximately 6mA) is generated within the Timer Unit. This switched feed is then used to control a timer circuit and is designed to "time-out" every 2.5 - 3 minutes. Flow would then stop after this period unless the operator generated a reset signal. The reset signal is generated merely by releasing and regripping the handswitch.

In order to avoid automatic flow shut-down in normal operation, a prompt signal is generated within the Timer system some 20 seconds before ' time-out '. This prompt signal is used to generate either an audible or visual prompt (or both) such that the operator is reminded to reset. The audible output is designed to give a continuous signal only during the prompt. Many proprietary beepers can be configured to given an intermittent output from a continuous signal.

The visual output is designed to give an indicator lamp a continuous signal when the handswitch is made and until the prompt signal is generated. At this point the lamp will flash for the prompt period.

A reset signal can be generated at any time during the timer cycle whether prompted or not but the Deadman function takes priority at all times!

A 0.4 second delay is built-in to the response time to allow a reset signal to be generated without the air solenoid dropping out and the pneumatic system losing pressure.

On existing Deadman systems all existing components can be used but for ease of installation it is recommended that the Timer system low-current handswitch feed is used. Also it is recommended that the FLUID TRANSFER 11101 series Deadman Handswitch is used as the switch contacts are particularly suited to the low-current switching levels. The switch has U.L. listing.

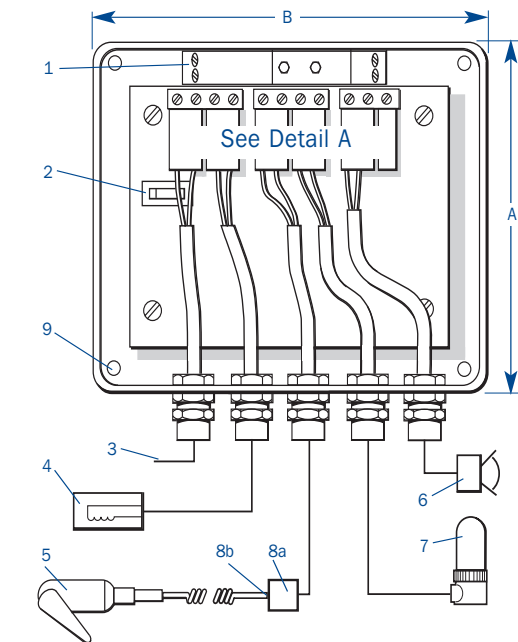

- | | |
|---|--|
| 1 Certified Shunt.
Diode Safety Barrier (Optional). | 6 Audible Bleeper (Optional). |
| 2 Fuse 2 amp. | 7 Vapour Proof Lamp 21 watts.
(Optional) voltage to be specified. |
| 3 Supply 12-28 volts DC. | 8a Junction Box (not supplied).
Must be water tight. |
| 4 Solenoid Operated Pneumatic
Valve (Optional) voltage to be
specified. | 8b Cable to be strain relieved. |
| 5 Deadman Handswitch (Optional). | 9 4 mounting holes Dia. 5mm. |

Dimensions

Part	A	Height	B	Weight
Deadman Timer System 10826	136mm	85mm	172mm	0.6 Kg

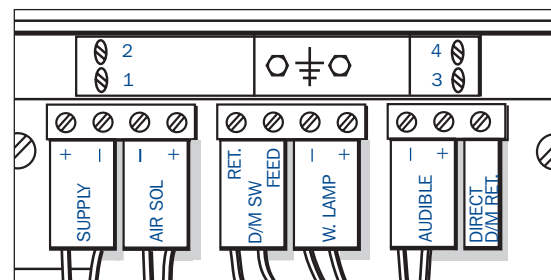

Detail A

Notes.

- Timer Unit to be located in a dry, clean electrically safe area away from high temperatures. (Preferably in the vehicle cab).
- Unit to be installed by suitably qualified personnel. All wiring connections to be checked before powering equipment as incorrect wiring can damage the equipment.
- When Shunt Diode safety barrier is fitted it is pre-wired. Connect the Deadman Handswitch to barrier terminals 3 & 4.

Part No	Description
DBA10826	STANDARD UNIT
DBA10826-1	C/W SHUNT DIODE SAFETY BARRIER
DAA11115	D'MAN HANDSWITCH C/W SUZIE CABLE 3-17m
676-846	AUDIBLE BLEEPER
DB26069-G	VAPOUR PROOF LAMP C/W GREEN LENS
LB43313TA	SOLENOID VALVE
LB43313TX	SOLENOID VALVE
DBA10826-PCB	PCB SPARE BOARD

FTI's policy of continuous improvement means we reserve the right to alter designs and specifications without notice.

The descriptions, illustrations and product references in the datasheet are for information purposes only and are not binding. (updated August 07)



Applications

Provides a highly visible indication / safety assurance of the condition of interlocks being monitored. Typically used as a Brake Interlock Monitoring System indicating which interlocked item is correctly or incorrectly stowed.

Features

- Ten large, high-intensity LED's are used to indicate Interlock status (dual colour LED'S to ensure a failed LED can not cause the true state of a circuit not to be shown)
- Current is limited to intrinsically safe levels so no sparking can occur.
- Permits the operator to quickly identify incorrectly stowed equipment
- Allows the operator to check the operation of the switches while several of the couplings etc. are removed from their stowage's.
- Can be retrofitted to vehicles fitted with electrically actuated brake interlock systems.

Options

- Retrofit version for vehicles where a Fluid Transfer Current Limiting Relay is installed.
- A 24v relay version.
- A 12v relay version.



Specification

The Fluid Transfer Interlock Monitor individually monitors up to ten interlock switches or circuits and provides a highly visible indication of the condition of each, thus providing additional safety assurance.

The unit has been designed to replace the simple series circuit typically used for vehicle brake interlock systems. These series circuits are susceptible to faulty switches sticking in the closed (stowed) position and masking the operation of the other switches. Whilst this fault remains undetected a potentially dangerous situation exists with the equipment effectively not being interlocked to the vehicle brakes.

The Fluid Transfer Interlock Monitor incorporates ten large, high intensity LED's that inform the operator which interlocks are open. This reduces the time taken to identify incorrectly stowed equipment and allows the operator to check the operation of the switches while several of the couplings etc. are removed from their respective stowage's. Interlock checks can then be performed during the normal refuelling operations on an ad-hoc basis or as part of the fuelling procedure. The time taken to perform interlock checks is greatly reduced as a result of this ability to check several switches simultaneously.



Interlock Monitor

Part No DBA12630

Technical Data

The Fluid Transfer Interlock Monitor incorporates ten large, high intensity LED's that inform the operator which interlocks are open. The Interlock Monitor separates the interlock system into ten parallel circuits, each circuit being electronically monitored. When the circuits are 'opened', (equipment removed from stowage) the unit changes the colour of the circuit LED from green to red. The unit ensures that the vehicle brakes are applied until all switches are 'closed' (equipment correctly stowed).

The current in the interlock circuits is limited to intrinsically safe levels such that no sparking can occur if a wiring fault develops. The use of dual colour LED's eliminates the possibility of the true state of a circuit not being shown due to a failed LED or lamp.

The unit can be easily retrofitted to vehicles that are fitted with electrically actuated brake interlock systems using interlock switches which are 'closed' when the equipment is stowed and which have been wired through a central junction box. The links in the junction box are removed to make the circuits parallel, a multi-core cable is installed between the junction box and the cab where the monitor box is mounted in view of the driver. The interlock monitor is then linked to the relay controlling the solenoid valve in the brake line.



Electrical Circuit

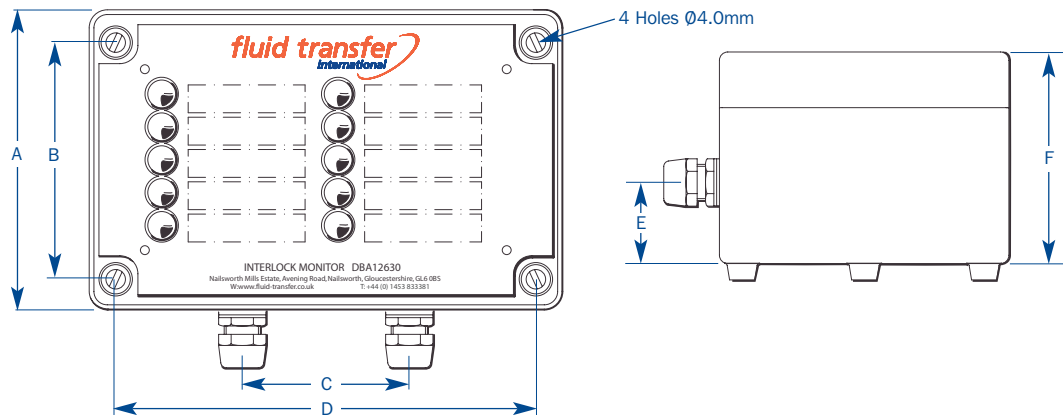
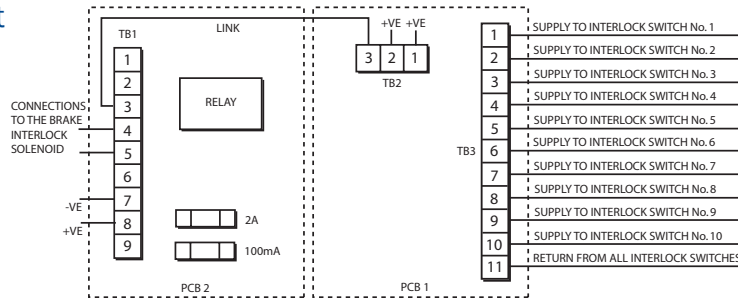

Dimensions

Part No.	A	B	C	D	E	F	Weight
DBA 12630	110	95	180	165	35	91	600g

All dimensions in (mm)

Options

Part No.	Item	Variant
DBA12630	Interlock monitor	Standard 24v Relay
DBA12630-1	Interlock monitor	12v Relay Version

Maintenance

No special maintenance is required only replacement of fuses in the event of unforeseen current surges.

FTi's policy of continuous improvement means we reserve the right to alter designs and specifications without notice.

The descriptions, illustrations and product references in the datasheet are for information purposes only and are not binding. (updated August 07)



Applications

Current limiting relay reducing current to intrinsically safe levels for protection against sparking should a wiring fault occur. Provides safe operation of interlocks in Deadman and other interlock systems.

Sizes

Versions available:

- 12Vdc
- 24Vdc

Features

- Overload protection of:
 - Switching current (limited to 2A)
 - Relay coil (limited to 100mA)
- Resilient mounting enclosure

Options

- Dual channel shunt diode safety barrier (if certification is required)



Specification

The Fluid Transfer Current Limiting Relay provides for the safe operation of Interlock Systems, Deadman Systems and in some cases automatic Recovery Tank Emptying Control Systems.

These very simple, reliable relays limit the system current to intrinsically safe levels such that no sparking can occur if a wiring fault develops. The relays must only be used in "simple" systems where no energy storing potential is possible, preferably using hermetically sealed proximity switches.

The relay is fully protected against overload by two fuses, one limiting the switching current to 2A and the other protecting the relay coil to 100mA. All switched inductive loads are protected against damaging "back – EMF's" by "quench" diodes.

Current Limiting Relay

Part No DA1859/60

Technical Data

Simple systems need not be certified but if certification is required, a dual channel shunt diode safety barrier can be specified on the low-current side of the relay.

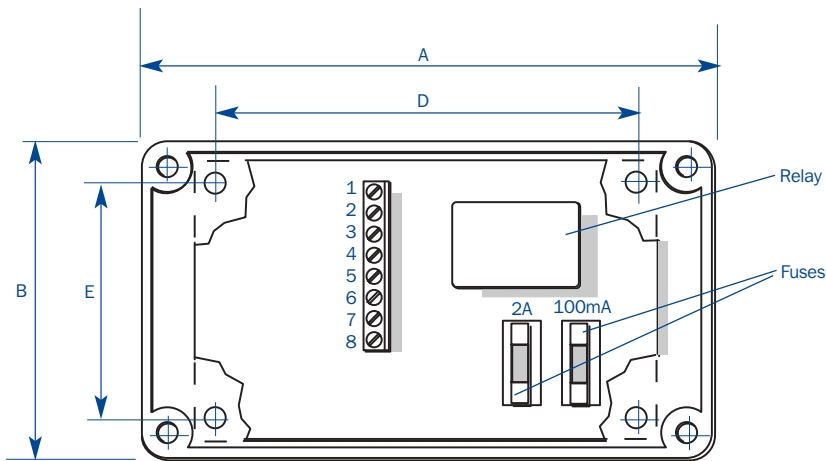

C = Height of box with cover on

View inside enclosure without cover

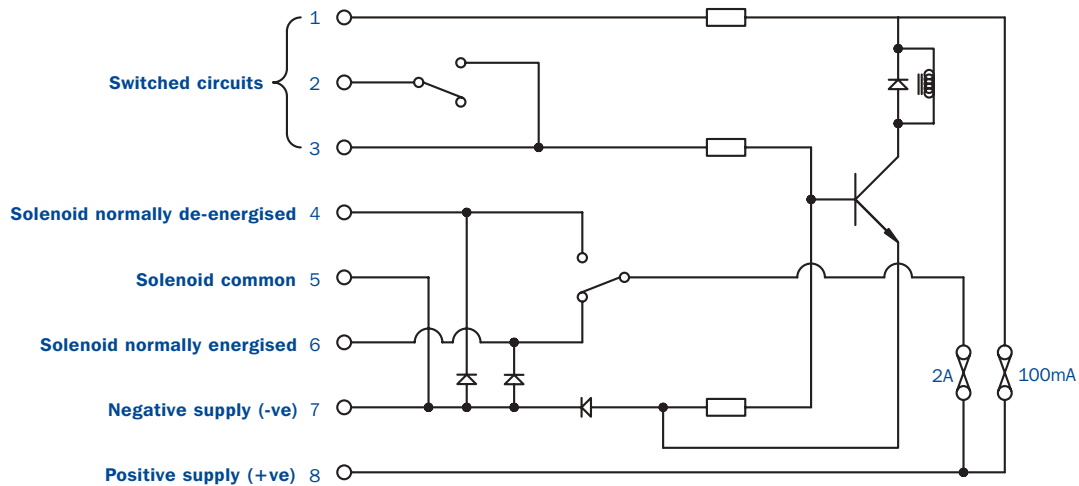

Current Limiting Relay Circuit diagram showing termination block identities

Dimensions

The Fluid Transfer Current Limiting Relay dimensions are as follows:

Part No	Item	A	B	C	D	E
DA1859	12V Current Limiting Relay	135	73	73	95	50
DA1860	24V Current Limiting Relay	135	73	73	95	50

Dimensions in (mm)

Spares

The following replacement Fuse are available on request:

Part No	Fuses		Relay
	2A	100mA	
DA1859	151-486	799-920	25D02C14B
DA1860	151-486	799-920	25D02C20B

FTi's policy of continuous improvement means we reserve the right to alter designs and specifications without notice. The descriptions, illustrations and product references in the datasheet are for information purposes only and are not binding.





Applications

Proximity Switch used for actuation of vehicle brake interlocks.

Features

- Robust moulded mounting case.
- Aluminium lid
- Switching device
- Strong permanent magnet
- Lid and cable entries.

Options

Can be used in conjunction with Current

Limiting Relay:

12 Volt (DA1859)

24 Volt (DA1860)



Specification

The Fluid Transfer Proximity Switch Assembly with Actuation Magnet consists of a sensitive switching mechanism bonded within a moulded enclosure with an aluminium lid and gasket.

A permanent magnet when introduced in close proximity to the enclosure causes the sensitive switching mechanism to change polarity. The unit is used for actuation of vehicle brake interlocks.



Proximity Switch

Part No DB0860

Technical Data

The Fluid Transfer Proximity Switch Assembly with Actuation Magnet consists of a sensitive switching mechanism bonded within a moulded enclosure with an aluminium lid and gasket.

A strong permanent magnet activates the internal proximity switch when placed near the enclosure. To ensure the accurate functioning is achieved the polarising slot of the magnet should be located in the same direction and directly above the guideline on the proximity switch housing. The proximity switch must be used in conjunction with cover and gasket to maintain its integrity.

Installation Note

Wiring connections: -

- White wire – Common
- Red wire – normally closed
- Yellow wire – normally open

After connecting the relevant wires, ensure the entry to the conduit connector is plugged with type silicone sealant or suitable equivalent in order to avoid possible water ingress from the conduit system.

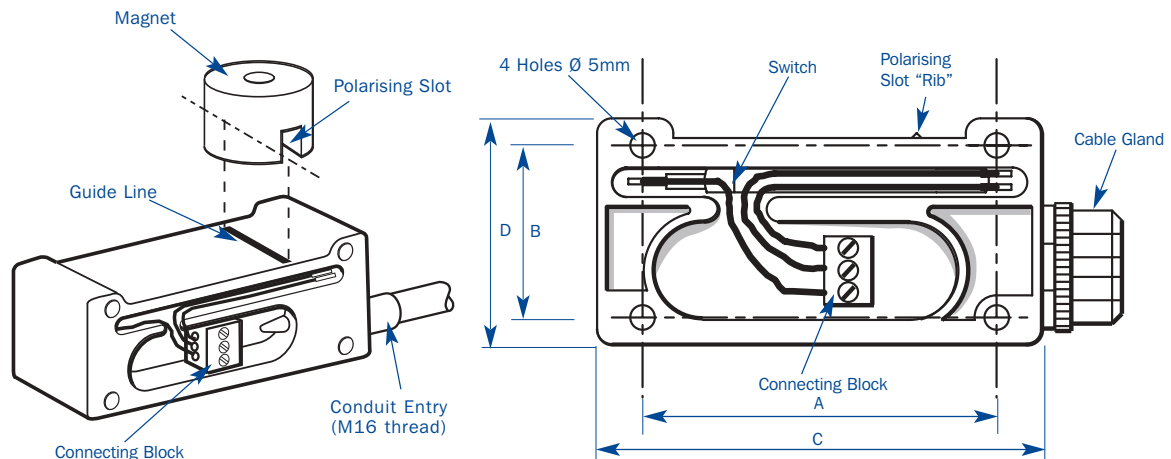

Dimensions

The dimensions of the Fluid Transfer Proximity Switch are as follows:

Part No	Item	A	B	C	D	Height E	Weight
DB0860	Proximity Switch	72	35	90.5	45	30	80grams

All dimensions in (mm)



Applications

Sealed lamp and enclosure used to provide light in explosive atmospheres, i.e. behind Visual Check Fuel Samplers (VCFS).

Features

- Rugged cast iron hot dipped galvanised body.
- Temperature resistant toughened well glass diffuser.
- Classification: EEx.d11B Flame proof T5 to BS5501 Part 5 (EN50018)
- IP protection to IP.65 to IEC 144

Options

The standard lamp assembly permits:

- Lamp voltages: 12v and 24v
- Colours: Clear, Red, Green, Amber and Blue

To use with VCFS the assembly includes:

- Shroud (not shown)
- Fixing bracket (not shown)



Specification

The Flameproof Lamp E501004 is used in locations possibly exposed to fuel vapours to provide light such as with the Fluid Transfer Visual Check Fuel Sampler (DDA11432) or as an indicating lamp with various coloured lamps.

The assembly consists of a cast iron enclosure, a toughened well glass cemented into a replaceable screw-on retaining ring. Weatherproofing is provided by a gasket located between the retaining ring and the base providing a degree of protection IP.65 to IEC 144. The unit comes as standard with a lamp-holder to accept a double pole (earth return) pygmy lamp.



Flameproof Lamp

E501004

Technical Data

The Flameproof Lamp E501004 consists of a cast iron enclosure, a toughened wall glass cemented into a replaceable screw-on retaining ring. Weatherproofing is provided by a gasket located between the retaining ring and the base providing a degree of protection IP.65 to IEC 144. The unit comes as standard with a lamp-holder to accept a pygmy bulb.

Area classification	Zones 1 & 2 – Apparatus Groups 11A & 11D.
Protection code/apparatus standard	EEx.d11B T5 to BS5501 Part 5 (EN50018)
Certificate Number	EX811262
Temperature Classification	Class T5 – 100 deg.C max. surface temperature to BS5501 Part 1 EN50014)

Note: In order to ensure that the lamp surface has cooled to a temperature below the T5 classification, the cover should not be removed within 3 minutes of isolation.

The Flameproof Lamp assembly is available with two types of bulb and different colour lenses as shown:

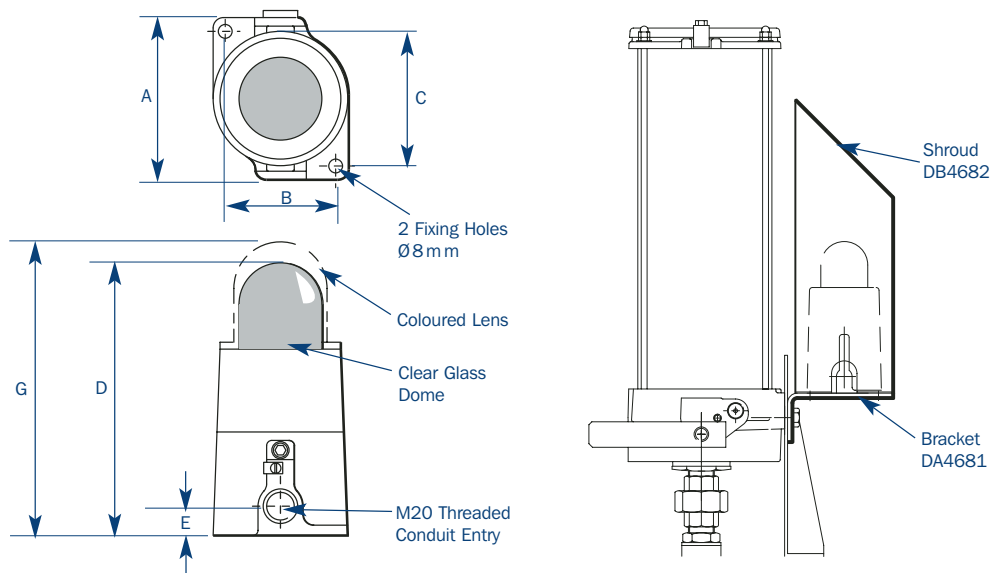

Dimensions

Part No	Item	A	B	C	D	E	F	Weight
E501004	Flameproof Lamp	94	64	78	158	17	170	2kg

Dimensions in (mm)

Options

Part Number	Description	Rating
PMY2415BC	Bulb Pigmy Clear	24v, 15w
PMY1215BC	Bulb Pigmy Clear	12v, 15w

Lens

Part No.	Colours
E501004	Clear
E501004-R-P	Red
E501004-G-P	Green
E501004-A-P	Amber
E501004-B-P	Blue

VCFS Kit (DA5008)

A kit to suit the VCFS includes DA4681 Bracket and DB4682 Shroud.

Part No.	Item
DA4681	Bracket
DB4682	Shroud

FTI's policy of continuous improvement means we reserve the right to alter designs and specifications without notice. The descriptions, illustrations and product references in the datasheet are for information purposes only and are not binding.



Applications

Simple 'at a glance' indication of fluid flow within a pipe or hose

Sizes

12.7mm ($\frac{1}{2}$ ")

25.4mm (1")

38.1mm ($1\frac{1}{2}$ ")

Features

- Rugged gunmetal body
- Borosilicate glass dome
- Nylon moulded ball
- Max working pressure 7 bar (100psi)
- Max pressure 11 Bar (150psi)
- Test pressure 22 Bar (300psi)



Specification

The Sho Flo Indicator is a simple method of observing flow in a hose or pipeline. The bowl shaped body is accessed via central tube in which a moulded ball is located. The central tube is viewed through a dome of glass, which is secured with a clamping ring. The passage of liquid through the tube causes the moulded ball to rise in the tube and start to rotate becoming visible in the glass dome. The Sho Flo device is also able to act as a non-return valve preventing flow in the opposite direction.



Sho Flo Indicator

Part No DA26302

Technical Data

The body of the Sho Flo Indicator is manufactured in Gunmetal and contains a central passage that passes through a chamber containing a moulded ball. The ball is viewed through a Borosilicate Glass dome secured by a gunmetal ring to the body. Before the liquid starts to flow the moulded ball remains hidden within its tube. The passage of liquid through the tube causes the moulded ball to rise in the tube and start rotating, becoming visible in the glass dome. The simplicity of the design minimises wear, ensuring exceptional reliability and long life.

The Sho Flo Indicator is suitable for maximum working pressures of 7bar (100psi) but will withstand pressures up to 15bar (200psi). The unit is tested to a pressure of 22bar (300psi). Maximum working temperature with glass dome 120°C. The Sho Flo will also act as a non-return valve.

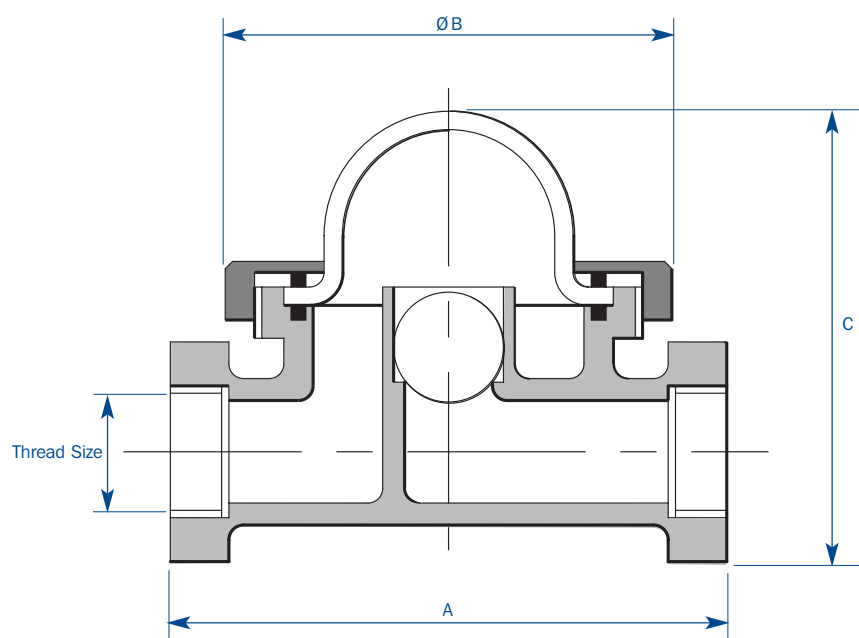

Dimensions

Part No	Option	Item	A	B	C	Thread Size (BSP)		
						(male)	(Female)	Weight
DA26302-1	Standard	12.7mm (1/2")	98	73	76	3/4"	1/2"	0.79kg
DA26302-2	Standard	25.4mm (1")	165	131	124	1 1/4"	1"	2.61kg
DA26302-3	Option on request	38.1mm (1 1/2")	200	124	146	2"	1 1/2"	5.11kg

Dimensions in (mm)

FTI's policy of continuous improvement means we reserve the right to alter designs and specifications without notice. The descriptions, illustrations and product references in the datasheet are for information purposes only and are not binding. (updated August 07)



Applications

Rotating hose joints subject to light bending moment load applications such as small hoses on elevated deck platforms.

Sizes Available

80mm and 100mm bore mounting flanges to DIN 28460.

Features

- Aluminium Alloy body.
- Viton Seals.
- Maximum working pressure 10.4 bar (150psi).
- Stainless Steel loose ball type bearings.
- Packed for life - no lubrication required.
- Electrical continuity through unit.



Specification

The Fluid Transfer Lightweight Aluminium Swivel is designed to give long maintenance free service in light bending moment loading applications.

The flow path is aluminium alloy, thus preventing any possible contamination of the fluid product. The fluid seals are designed to provide minimal resistance to rotation allowing ease of use whilst remaining impervious to kerosene-based fuels.

The reduced weight of the product coupled with the compact size allows it to be fitted in confined spaces where space and weight are a premium. By using the lightweight swivel in applications such as deck hoses both cost and weight are reduced providing value for money efficiency with maximum performance and quality.

Note :- Unsuitable for high bending moments. FTi Heavy Duty Swivels should be used in these applications.



80mm and 100mm Lightweight Aluminium Swivels

Part No DBA11901/DBA11902

Technical Data

The swivel is offered in two sizes; 80mm and 100mm with the following features.

- Mounting flanges to DIN28460 series complete with pre-tapped mounting holes.
- Stainless steel ball bearings running in low-friction machined bearing surfaces.
- Viton seals.
- Maximum working pressure 10.4 bar (150psi).
- Maximum test pressure 20.8 bar (300psi).
- Electrical continuity is maintained through the unit.
- No lubrication required.

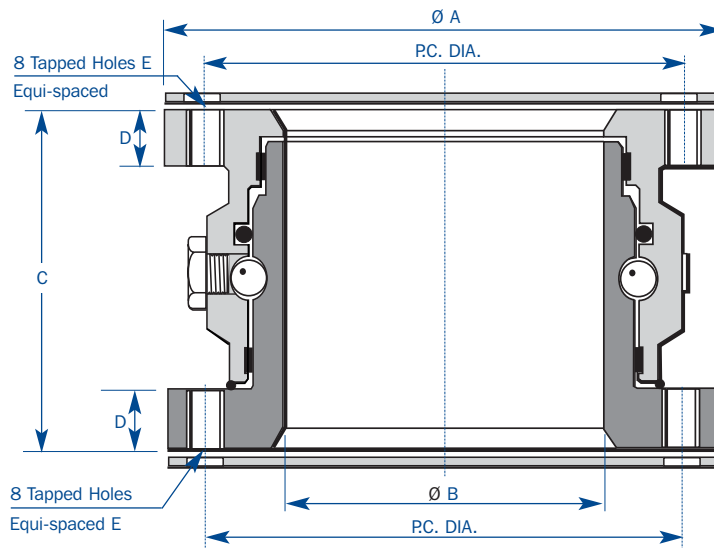

Dimensions

Swivel Size	A	B	P.C. DIA.	C	D	E	Weight
80mm swivel DBA11902	Ø154mm	Ø80mm	Ø130mm	105mm	18mm	M10	2.7 Kg
100mm swivel DBA11901	Ø174mm	Ø100mm	Ø150mm	115mm	20mm	M12	3.4 Kg

Service.

Fluid Transfer International offers a full service exchange facility on all our swivels. This allows minimal operational disruption during maintenance schedules with guaranteed product quality.





Applications

Rotating hose joints where mechanical radial loads are applied such as those at Hydrant Dispenser intake hose booms.

Sizes Available

80mm and 100mm bore with standard flanges to DIN28460 Series.

Features

- Stainless Steel Inner, Plated Steel Outer.
- Viton Seals
- Maximum working pressure 10.4 bar.
- Sealed for life (ball race type) bearings. giving low swivel resistance and high wear resistance.
- Seal design provides low resistance to rotation.
- All components in contact with fluid constructed from Stainless Steel.

Options

Other versions available are :

- ASA or ISO Flanges
- 90 elbows
- 180 elbows
- Short/Standard radius elbows



Specification

The Fluid Transfer heavy-duty swivel is designed to give long maintenance free service under the most arduous operating conditions.

The flow path is stainless steel, thus preventing any possible contamination of the fluid product. The fluid seals are designed to provide minimal resistance to rotation allowing ease of use whilst remaining impervious to aviation fuels.

The heavy-duty construction of the swivel provides a robust solution suitable for applications where mechanical radial loads are imposed. The swivels are used extensively on hydrant dispenser intake booms and pantographs where safety and performance cannot be compromised.



80mm and 100mm Heavy Duty Stainless Steel Swivels

Part No DC1233/DC1113

Technical Data

The swivel is offered in two sizes; 80mm and 100mm with the following features.

- Mounting flanges to DIN28460 series complete with pre-tapped mounting holes.
- Sealed and packed for life maintenance free heavy duty bearings.
- Seals manufactured from Viton material.
- Maximum working pressure 10.4 bar (150psi).
- Maximum test pressure 20.8 bar (300psi).

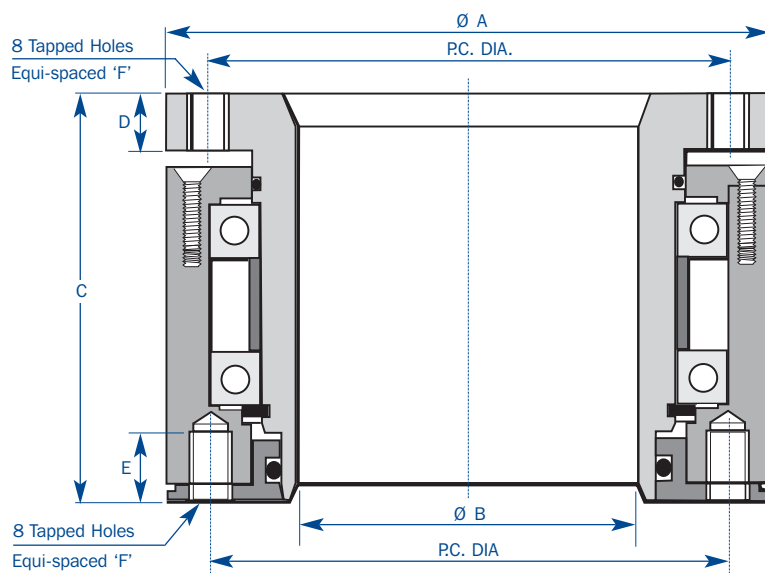

Packing Dimensions

Swivel Size	A	B	P.C.DIA.	C	D	E	F	Weight
80mm swivel DC1233	Ø154mm	Ø80mm	Ø130mm	105mm	13mm	15mm	M10	9.2 Kg
100mm swivel DC1113	Ø174mm	Ø100mm	Ø150mm	120mm	16mm	15mm	M12	12.3 Kg

Options

Other versions of these swivels are available

- ASA or ISO Flanges
- 90 elbows
- 180 elbows
- Short/Standard radius elbows

Maintenance

Fluid Transfer International offers a full service exchange facility on all our swivels. This allows minimal operational disruption during maintenance schedules with guaranteed product quality.

FTi's policy of continuous improvement means we reserve the right to alter designs and specifications without notice. The descriptions, illustrations and product references in the datasheet are for information purposes only and are not binding.





Applications

- Provides a 'Clear & Bright' visual examination of fuel.
- Enables the temperature and density of a sample to be measured (with optional thermometer, hydrometer and housing).
- Enables the dryness of the sample to be checked using the Shell Water Detector or the Exxon Hydrokit (with optional self sealing valve).

Capacities Available

Standard units are 2, 3.3, 4, 6 and 8 litres.

Features

- Aluminium body, Boron silicate glass.
- High Nitrile Seals.

Options

- Thermometer and hydrometer housing.
- Self-sealing valve for Shell Water (Detector or Exxon Hydrokit).
- Flameproof backlamp and shroud.
- Spring-close (deadman type) VCFS fill valve.



Specification

The Fluid Transfer Visual Check Fuel Sampler (VCFS) is a closed circuit fuel sampling system designed to provide a safe, easy and convenient method of carrying out the industry standard 'Clear & Bright' visual examination of aviation fuel.

The vessel consists of a strong, clear glass tube sandwiched between a base and a hinged lid assembly. The base incorporates a drain valve, a fill port, a hydrokit sampler draw off connection and a mounting flange. The internal surface of the base is conical in profile and finished in a white epoxy coating to assist visual detection of free water and/or dirt particles. The fill port is designed to cause the fuel sample to swirl around the sides of the glass tube; the resultant vortexing effect causes any solid contaminants to concentrate towards the centre of the glass to assist visual detection.

The mechanical design of the VCFS prevents vibration and thermal expansion from overstressing the glass tube. The hinged lid is large enough to allow a hand to reach inside the VCFS to enable the glass tube and base to be wiped clean for ease of maintenance and assured performance.

All vessels are offered with a range of options allowing bespoke functionality for the end user, at affordable prices, using proven standard designs.



Closed Circuit Visual Check Fuel Sampler

Part No DDA11432

Technical Data

The FLUID TRANSFER Visual Check Fuel Sampler (VCFS) is a closed circuit fuel sampling system and is designed to provide a safe, easy and convenient method of carrying out the classic and widely used 'Clear & Bright' visual examination of aircraft fuel. The 3.3 litre unit is termed a 'Standard' VCFS being the optimum size for vehicle applications, large enough to obtain a complete sample yet sufficiently compact to fit unobtrusively on a small hydrant dispenser. The mechanical design of the VCFS prevents vibration and thermal expansion from over stressing the glass tube. The hinged lid is large enough to allow a hand to reach inside the VCFS to enable the glass and base to be wiped clean.

Options

- Housings are available to suspend within the VCFS enclosure to accept a thermometer and hydrometer.
- A self sealing valve assembly is available which allows the Shell Water Detector (syringe and capsule) or Exxon Hydrokit (evacuated glass tube) to draw a fuel sample from the base of the VCFS.
- A small handpump and non return valve are available if the VCFS cannot be gravity drained.
- A flame proof lamp is available complete with mounting bracket (to be positioned behind the VCFS glass tube for night operation).

	2 Litre DDA11460	Standard 3.3 Litre DDA11432	4 Litre DDA11501	6 Litre DDA11480	8 Litre DDA11502
Thermometer and Hydrometer housing	Not available	DBA11465	DBA11465	DBA11465	DBA11465
Exxon Hydro Kit	DBA11402	DBA11402	DBA11402	DBA11402	DBA11402
Shell Water detector	DBA11416	DBA11416	DBA11416	DBA11416	DBA11416
Handpump and non return valves	HP110	HP110	HP110	HP110	HP110
Flameproof Lamp	DA5008	DA5008	DA5008	DA5008	On request
Replacement Glass	DAM11452	DAM11427	DAM11496	SK885	DAM11499

Hydrometer DA26303 and Thermometer DA26304 (to suit housing DBA11465) are available as optional items on request.

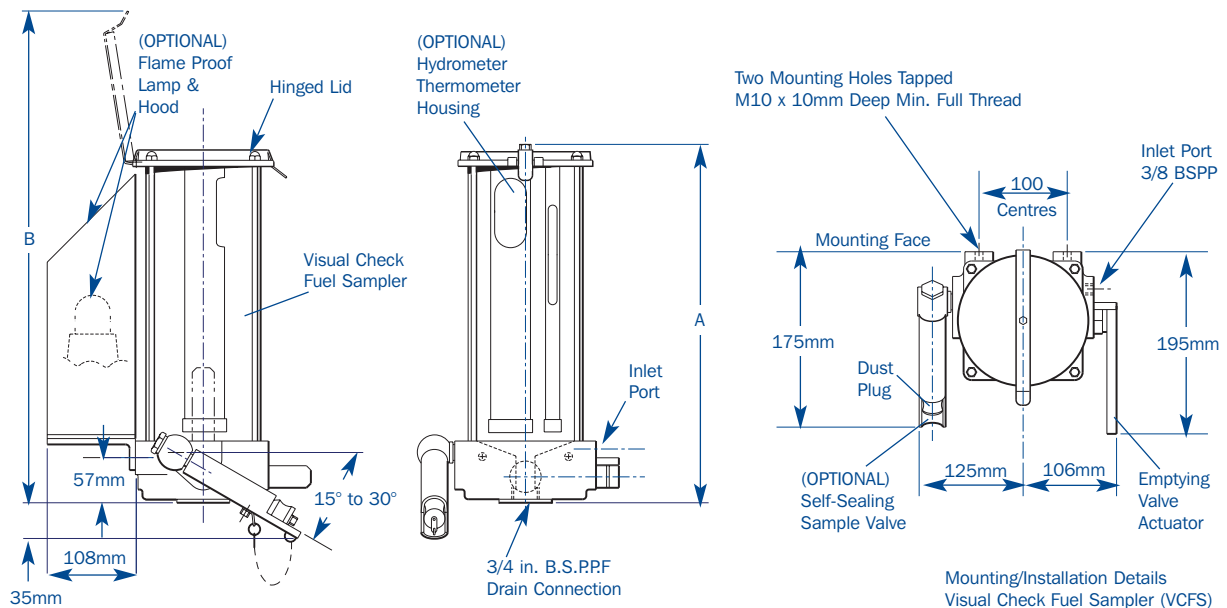

Dimensions

	2 Litre DDA11460	Standard DDA11432	4 Litre DDA11501	6 Litre DDA11480	8 Litre DDA11502
Unit height (lid closed)(A)	280mm	400mm	465mm	555mm	825mm
Unit height (lid open)(B)	440mm	560mm	625mm	715mm	985mm
Weight(dry)	3.3 Kg	4.0 Kg	4.2 Kg	6.3 Kg	8.4 Kg

Due to the fragile nature of glass special packaging is required for transportation. Fluid Transfer International is able to supply packaging and delivery for all items at the customer's request

FTI's policy of continuous improvement means we reserve the right to alter designs and specifications without notice.

The descriptions, illustrations and product references in the datasheet are for information purposes only and are not binding. (updated August 07)

T: +44 (0)1453 833 381

E: sales@fluidtransfergroup.com

W: fluidtransfer.com

80 & 160 Litre Visual Fuel Sampler



Part No.s DC20000-1/2 & DC9621

Applications

Provides a 'Clear & Bright' visual examination of fuel. Typical unit for taking samples from free-standing static fuel filter water separators.

Features

- Material - Aluminium body, boron silicate glass.
- Seals – High nitrile rubber

Options

1. The temperature and density of a sample can be measured (with optional thermometer, hydrometer and housing).
2. The dryness of the sample can be checked using the Shell Water Detector or the Exxon Hydrokit (via an optional self-sealing valve).
3. A flameproof back lamp and shroud are available for night operations.
4. Spring close (Deadman type) VCFS fill valve.
5. Hand pump and non-return valve (necessary if the VCFS cannot be drained under gravity).



Specification

The Fluid Transfer Visual Check Fuel Sampler (VCFS) is a closed circuit fuel sampling system designed to provide a safe, easy and convenient method of carrying out the industry standard 'Clear & Bright' visual examination of aviation fuel. The 80 and 160 litre VCFS are the latest addition to our range designed specifically for fixed installations where larger sample volumes are required.

The vessel consists of a strong borosilicate clear glass tube sandwiched between a base and latched lid assembly. The mechanical design of the VCFS prevents vibration or thermal expansion from over stressing the glass tube. The latched lid provides access to enable the glass tube and base to be wiped clean for ease of maintenance and assured performance. The internal surface of the base is conical in profile and finished in a white epoxy coating to assist visual detection of free water and/or dirt particles. The fill port is designed to cause the fuel sample to swirl around the sides of the glass tube; the resultant vortex effect causes any solid contaminants to concentrate towards the centre of the glass to assist visual detection.

The base incorporates a drain valve, a fill port, a "Kydrokit" sampler draw-off connection and a mounting flange. An integral emptying valve is built into the base of the VCFS and can be connected to either a gravity line or to hand operated pump for emptying. (It is assumed that the drain line will be routed to a suitable product recovery tank or waste product tank).



80 & 160 Litre Visual Fuel Sampler

Part No.s DC20000-1/2 & DC9621

Technical Data

Fuel enters the glass vessel, usually under gravity, via a fire safe stainless steel ball valve fitted with a spring-closed actuator. If there is insufficient head of fuel to generate an acceptable filling rate, an optional hand pump is available to assist the filling operation.

Incoming fuel is caused to vortex thereby concentrating debris and/or suspended water at the centre of the vessel making it easier to visually detect. An engraved level indicator gives an approximate measure of the sample volume. The inlet pipe is fitted with a self sealing valve assembly, which is designed to accept either the Shell Water Detector syringe and capsule or the Exxon Hydrokit test tube,

The vessel is emptied by means of a 3-position, 3-ported valve which routes the fuel either to a return line leading to a suitable product recovery tank or to an external drain connection terminating in a Kamlock adapter. (Clean and dry samples would be routed to the recovery tank, contaminated samples would be routed to the external drain connection for subsequent disposal).

All materials in contact with the fuel are free from "yellow metals". Pipework and flanges are of 304L stainless steel. The base of the vessel is conical in profile to ensure complete product drainage and is constructed in stainless steel.

The support frame is robustly designed and constructed in stainless steel. The lid is fabricated in stainless steel, is removable and retained with latches. Venting is achieved through the tubular handle. The handle openings are fitted with wire gauze flame traps.

Options

The following optional items are available

1. A housing to facilitate insertion of optional thermometer, hydrometer (for temperature and density measurement).
2. Self sealing valve assembly to accept Shell Water Detector (syringe and capsule) or Exxon 'Hydrokit' (evacuated glass tube) to allow a fuel sample to be drawn from the base of the VCFS.
3. Flameproof back lamp and shroud (for night operations).
4. Spring close (Deadman type) VCFS fill valve.
5. Hand pump and non-return valve (necessary if the VCFS cannot be drained under gravity).

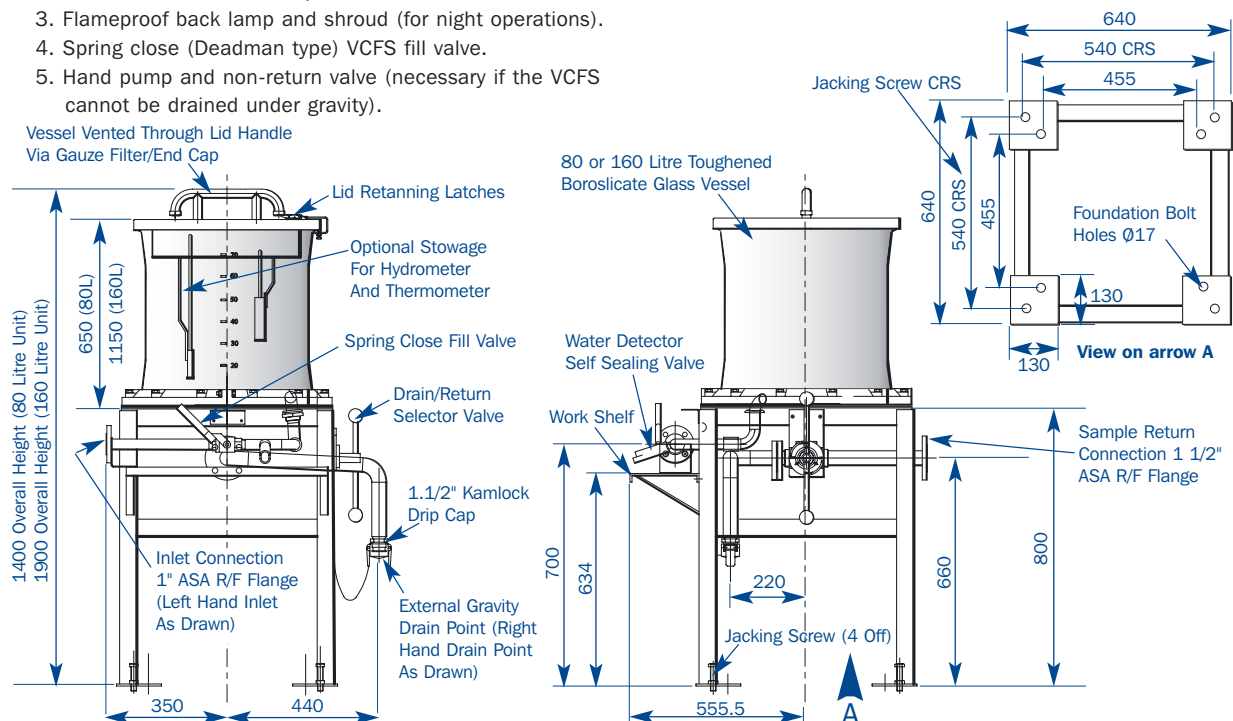

Standard unit is as drawn ie. with left hand inlet and right hand external drain. The unit is also available with optional right hand external drain. The return connection is always located at the rear of the unit.

The support frame stands on 4 footpads with jacking bolts for levelling and provision for floor bolts (not supplied).

It is recommended that the feet are imbedded in cement before being bolted down as it is essential the bolts when finally tightened down do not impose distortion on the base resulting in breakage of the glass.

VCFS	Part No.	Thermometer & Hydrometer Housing	Exxon Hydrokit	Shell Water Detector	Hand Pump & Non - Return Valves	Flameproof Lamp	Glass
80 Litre Left -hand	DC20000-1	DC9421*	DBA11402	DBA11416	HP110	DA5008	PS450-500
80 Litre Right -hand	DC20000-2	DC9421*	DBA11402	DBA11416	HP110	DA5008	PS450-500
160 Litre (Standard)	DC9621	DC9421*	DBA11402	DBA11416	HP110	DA5008	PS450-1000

*Thermometer and hydrometer not included

Due to the fragile nature of glass special packaging is required for transportation. Fluid Transfer International will supply packaging and delivery for all items on customer request

FTi's policy of continuous improvement means we reserve the right to alter designs and specifications without notice.

The descriptions, illustrations and product references in the datasheet are for information purposes only and are not binding.



Applications

Provides electrical bonding between refuelling equipment, aircraft and bulking sites.

Features

Robust maintenance-free construction;

- Stainless steel housing spring and centre pin.
- Oilite bushings.
- Aluminium alloy spring housing.
- Zinc plated mild steel drum, cheek plate and mounting bracket
- Damped rewind system prevents over-speed.
- Ratchet / pawl contains spring tension during deployment.
- Cable guide and rubber bump stop to reduce damage to cable.
- Requires no lubrication.
- Maximum resistance 0.50 ohms.

Options

Standard unit comes complete with 36m copper braided, clear PVC covered cable with small brass clamp.

Cable Options

- Low temperature (-19°C to -40°C).
- High visibility cable with increased luminosity.

Clip Options

- Large brass clamp
- Plated clip



Specification

The Fluid Transfer Spring Rewind Bonding Reel provides electrical bonding between refuelling equipment, aircraft and fuel depot sites. An internally protected electrical contact is provided which ensures good reliable continuity between the mounting bracket and bonding cable, with a resistance value better than 0.5 Ohms.

A ratchet and pawl mechanism is used to restrain the automatic rewind system while the bonding cable is deployed. The ratchet and pawl mechanism requires no lubrication. Pulling and releasing the cable following deployment activates automatic rewind. The reel will then rewind at a controlled rate due to the glycerine viscous damping mechanism. Rewind spring life is also promoted by the viscous rewind damping mechanism. Positive locking of the reel is not required as the spring rewind retains the cable in the retracted position. A cable guide acts both to guide the cable into the reel and as a positive stop against a rubber ball fitted to the bonding cable.



Spring Rewind Bonding Reel

Part No DDA12221

Technical Data

The unit is capable of high frequency operation with only high quality materials used in its construction. The centre pin is made of stainless steel, mounted within oilite bushings and the spring housing is manufactured in aluminium alloy. The drum, cheek plates and mounting bracket are manufactured in zinc plated mild steel. Provision is made for seventy-two operational turns with five further pretension turns to secure the cable. There are four separate guide positions permitting mounting and operation in any orientation.

Options

The Spring Rewind Bonding Reel is available with varying lengths and types of cable and three different clamp types. The standard unit comes complete with copper braided cable suitable for use down to -19°C (DA9519), rubber bump stop (DAM12244) and a small brass clamp (0100213002). A UK MoD Approved Version is also available.

Cable options

- Clear PVC covered copper braided cable Ø3.4mm with a clear PVC cover Ø5.4mm dia (suitable for applications above minus 19°C DA9519).
- Low temperature cable for applications between -19°C to -40°C SK2665.(NSN 4930 -99 -2084 088)
- High visibility cable with increased luminosity DW20749.

Clamp options

- Large brass clamp (0100213001).
- Mild steel plated clamp (401-0050-35) MoD Version.

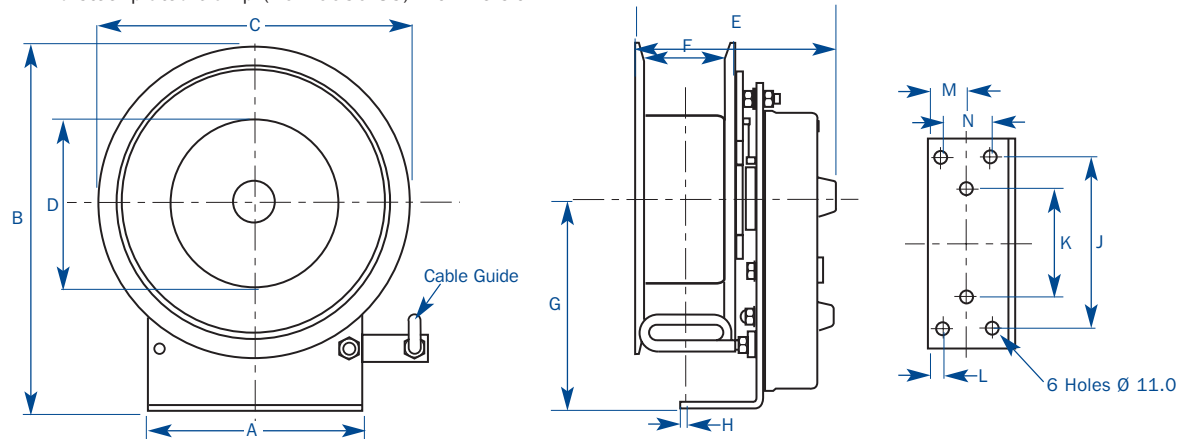

Item	Part No.	Length	Cable Type	Standard Clamp
Spring Rewind Bonding Reel	DDA12221-2	30m	Copper Braided, Clear PVC Covered	Small Brass
Spring Rewind Bonding Reel	DDA12221-3	25m	Copper Braided, Clear PVC Covered	Small Brass
Spring Rewind Bonding Reel	DDA12221-4	36m	Low Temperature Cable	Small Brass
Spring Rewind Bonding Reel	DDA12221-5	30m	Low Temperature Cable	Small Brass
Spring Rewind Bonding Reel	DDA12221-6	25m	Low Temperature Cable	Small Brass
Spring Rewind Bonding Reel	DDA12221-7	15m	Low Temperature Cable	Small Brass
Spring Rewind Bonding Reel	DDA12221-8	40m	Copper Braided, Clear PVC Covered	Small Brass
Spring Rewind Bonding Reel	DDA12221-9	15m	Copper Braided, Clear PVC Covered	Small Brass
Spring Rewind Bonding Reel	DDA12221-10	15m	High Visibility Cable	Small Brass
Spring Rewind Bonding Reel	DDA12221-11	25m	High Visibility Cable	Small Brass
Spring Rewind Bonding Reel	DDA12221-12	30m	High Visibility Cable	Small Brass
Spring Rewind Bonding Reel	DDA12221-13	36m	High Visibility Cable	Small Brass
Spring Rewind Bonding Reel	DDA12221-14	40m	High Visibility Cable	Small Brass
NATO Stock No. Version 7MTE/4930-99-1260548	DDA12220	36m	Copper Braided, Clear PVC Covered	Small Brass
NATO Stock No. Version 7MTE/6150-99-4832095	DDA12220-1	36m	Low Temperature Cable	Mild Steel Plated Clip

Dimensions.

A	B	C	D	E	F	G	H	J	K	L	M	N
170	292	Ø250	Ø130	160	65	167	6	140	90	10	30	40

Shipping weight (with 36m cable and clamp) = 10 kg. Dimensions in mm.

Maintenance

Warning: The internal spring of this unit is extremely strong and requires special tooling to dismantle and reassemble. DO NOT ATTEMPT TO RECTIFY ANY FAULTS, other than replacing the cable or retensioning the drum, return the unit to Fluid Transfer International Limited for repair. Any attempt to rectify in the field could result in injury.

FTI's policy of continuous improvement means we reserve the right to alter designs and specifications without notice.

The descriptions, illustrations and product references in the datasheet are for information purposes only and are not binding. (update August 07)



Applications

- Bonding Reel provides electrical connection between refuelling equipment, aircraft and bulking sites.
- Lanyard Reel provides physical connection between Hydrant Dispenser and Pit Valve.

Features

- Stainless steel cheek plates, mounting bracket and centre pin, rigid PVC hub.
- Internally protected electrical contact <0.2 Ohms resistance.
- Adjustable rotational brake to prevent overrun.
- MOD Approved Version
NATO Stock Number
7MTE/2590-99-301-6197*

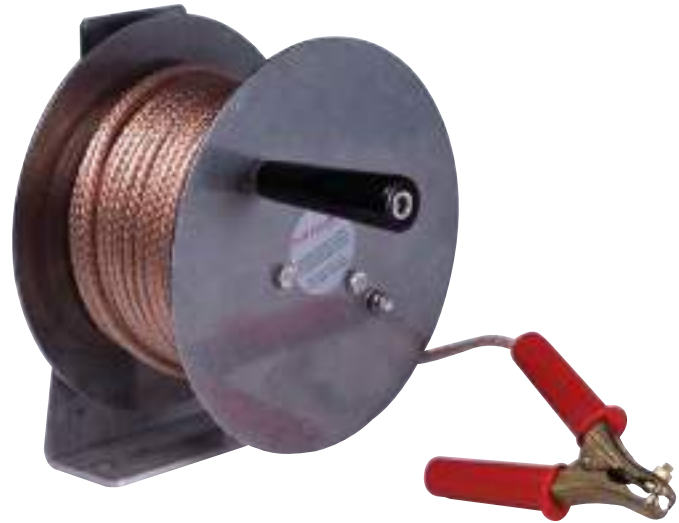

Specification

Fluid Transfer have developed a standard multi-purpose reel. The reel may be used as both a bonding and lanyard reel. As a bonding reel the unit provides electrical bonding between refuelling equipment, aircraft and bulking sites. As a lanyard reel the unit provides connection between a Hydrant Dispenser and the pit valve for manual emergency shut down of fuelling operations.

The unit will be subjected to a high frequency of operation. To ensure longevity and operational performance only high quality materials are used in construction. Cheek plates, mounting bracket and centre pin are in stainless steel with the hub manufactured in rigid PVC.

An adjustable rotational brake is incorporated in the design, preventing reel overrun. Also an internally protected electrical contact is provided. This ensures good reliable continuity between the mounting bracket and bonding cable, with a resistance value better than 0.2 Ohms. Positive locking of the reel can be provided by using the bonding clip in conjunction with an optional the slotted inner cheek plate and bracket.

Hand Rewind Bonding Reel and Hydrant Pit Valve Lanyard Reel

Part No DCA12250

Technical Data

Bonding and Lanyard Reels come complete with mounting bracket and can be supplied with customer specified options to suit the end user, providing tailored operational solutions at competitive pricing.

Bonding Reel Options

Cable options

- Clear PVC covered copper braid (DA9519).
The copper is 3.4mm in diameter and the PVC cover is 5.4mm in diameter. This cable is suitable for applications above minus 19°C.
- Low temperature cable (SK2665) suitable for applications below minus 19°C.
- High visibility cable DW20749. This cable has increased luminosity.

Clamp Options

- Standard Reel comes complete with brass clamp. (0100213002)
- Optional Plated clamp. (401-0050-035)

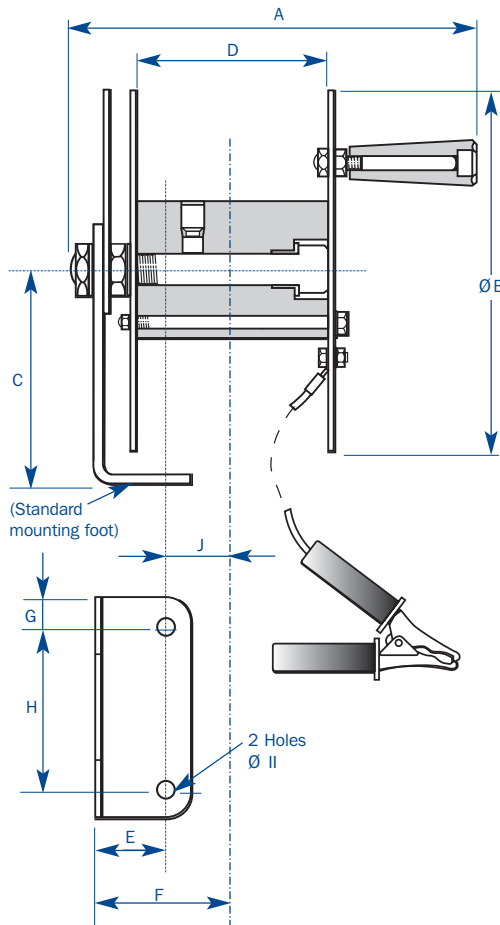

Part No	Cable length	Cable type
DCA12250	Reel Only	
DCA12250-1	10m	Copper braid clear PVC cover
DCA12250-2	20m	Copper braid clear PVC cover
DCA12250-3	30m	Copper braid clear PVC cover
DCA12250-4	10m	Low temperature cable
DCA12250-5	20m	Low temperature cable
DCA12250-6*	30m	Low temperature cable
DCA12250-7	10m	High visibility cable
DCA12250-8	20m	High visibility cable
DCA12250-9	30m	High visibility cable

* MOD Approved version

Lanyard Reel options.

The Lanyard Reels can be supplied with two attachment methods: a 'Crew Hook' DA4284 or a 'Dog Clip' DA21957 assembly. Various lanyard lengths are also available.

Part No	Cable length	Cable type
DA4284-1	15m	Cable & 3" Crew Hook Assembly
DA4284-2	20m	Cable & 3" Crew Hook Assembly
DA4284-3	30m	Cable & 3" Crew Hook Assembly
DA21675-1	15m	Cable & 20mm HD Turnbuckle Dog Clip Assembly
DA21675-3	20m	Cable & 20mm HD Turnbuckle Dog Clip Assembly
DA21675-2	30m	Cable & 20mm HD Turnbuckle Dog Clip Assembly

Dimensions.

Part	A	B	C	D	E	F	G	H	J	Mass
Bonding Reel DCA12250-3	210mm	Ø185mm	115mm	96mm	30.5mm	75mm	12.5mm	90mm	45.5mm	4.8 Kg

All dimensions are maximum dimensions. The mass is based on 30m of standard bonding cable fitted to the unit and may vary depending on the options the customer exercises.



2.1/2 Inch Aviation Tank Unit



Part No DCA10460/DCA10461/DCA10462-5

Applications

Bottom loading points on mobile fuelling equipment, fixed installation supply outlets, and coupling points on portable fuelling trolleys, test rigs and meter proving rigs.

Connections Available

- 3" ASA 150 Flange
- DIN 28460-80 Flange
- 2.1/2" BSP Female Thread
- 3" BSP Female Thread
- 2.1/2" NPT Female Thread
- 3" NPT Female Thread

Features

- Maximum working pressure 10.4 bar (150 psi).
- Test pressure 20.8 bar (300 psi).
- Low pressure drop, comparable to other manufactures' valves.
- No plated component in contact with fuel and no internal fixings – prevents possible contamination.
- Seals high nitrile (BUNA-N).
- Easily replaceable stainless steel valve seat.
- Inexpensive replaceable connector in high strength Aluminum Bronze Alloy.

Options

- Pressure assisted sealing cap.
- Non-standard flanges can be supplied to suit requirements.
- Pressure equalised opening for internal coupling pressures in excess of 5.5 bar (80 psi).
- 'Dedicated' product selectivity.
- Integral pressure tapping or sampling point – velocity head difference less than 0.076 bar (1 psi).



Specification

The Fluid Transfer 104 Series Tank Units are light-weight, 'non-yellow metal', self sealing valves, designed to meet the stringent demands of the aircraft refuelling industry. The tank unit design contains a spring-returned plunger with integrated circumferential seals. The action of engaging the coupling forces back the plunger, breaking the seal and allowing liquid to flow through the coupling.

Applications include bottom loading points on mobile fuelling equipment, fixed installation supply outlets, and coupling points on portable fuelling trolleys, test rigs and meter proving rigs. The valves conform to British, U.S. and ISO coupling connection and strength requirements, and are compatible with all makes of pressure refuelling nozzles.





2.1/2 Inch Aviation Tank Unit

Part No DCA10460/DCA10461/DCA10462-5

Features

- Maximum working pressure 10.4 bar (150 psi).
- Test pressure 20.8 bar (300 psi).
- Low pressure drop, comparable to other manufactures' valves.
- No plated component in contact with fuel and no internal fixings – prevents possible contamination.
- Easily replaceable stainless steel valve seat.
- Inexpensive replaceable connector in high strength Aluminum Bronze Alloy.

Options

- Pressure equalised opening for internal coupling pressures in excess of 5.5 bar (80 psi).
- 'Dedicated' product selectivity.
- Integral pressure tapping or sampling point – velocity head difference less that 0.076 bar (1 psi).
- Pressure assisted sealing cap.
- Non-standard flanges can be supplied to suit requirements.
- Tank unit options may be added using:

- Suffix A - 1/4" NPT tapping.
- B - 3/8" BSP tapping.
- P - Pressure equalised opening.
- S1 - S5 - Selectivity (state positions).
- ie. DCA10460.A.PS1

Dimensions

Item	Part No.	A	B	C	D	Flange Type	Weight
Tank Unit	DCA10460	Ø190mm	Ø76mm	140mm	23mm	3" ASA 150	2.7 Kg
Tank Unit	DCA10461	Ø154mm	Ø76mm	130mm	13mm	DIN 28460-80	1.8 Kg
Tank Unit	DCA10462	Ø115mm	2.1/2" BSP	140mm	-	-	1.6 Kg
Tank Unit	DCA10463	Ø115mm	3" BSP	140mm	-	-	1.6 Kg
Tank Unit	DCA10464	Ø115mm	2.1/2" NPT	140mm	-	-	1.6 Kg
Tank Unit	DCA10465	Ø115mm	3" NPT	140mm	-	-	1.6 Kg
SEALING CAP	DBA10440	Ø110mm	28mm	200mm	-	-	0.3 Kg
STOWAGE ADAPTOR KIT	DCA10203	Ø110mm	25mm	-	-	-	0.4 Kg

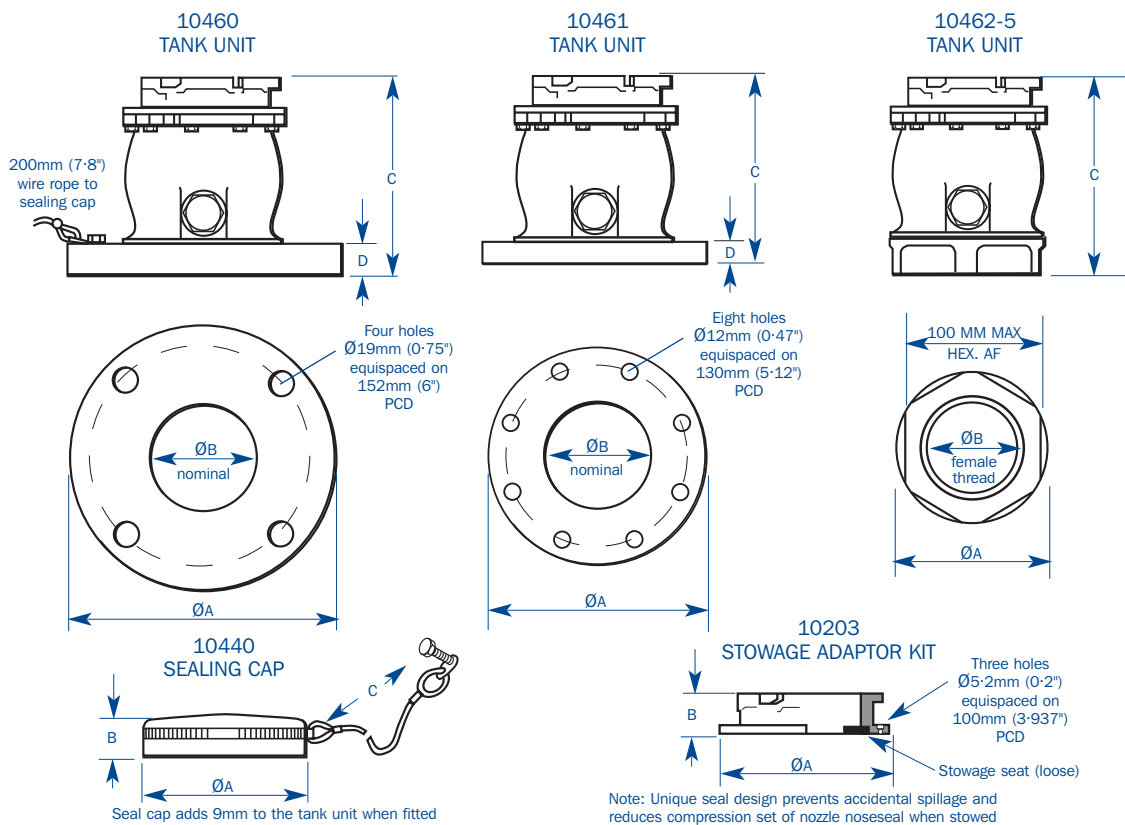

FTI's policy of continuous improvement means we reserve the right to alter designs and specifications without notice.
 The descriptions, illustrations and product references in the datasheet are for information purposes only and are not binding. (updated August 07)





Applications

Ensures correct stowage of the HEPC Nozzle actuating either an electrical or pneumatic switch.

Size Available

- Two sizes to suit Avery Hardoll and JC Carter Nozzles.

Features

- Cast Aluminium base, plated steel guide.
- Aluminium alloy connector.
- Electrical or Pneumatic interlocking.



Specification

The FLUID TRANSFER HEPC Nozzle Stowage is an integrated unit that provides a positive locking engagement, nose protection and a built-in interlock switch. This switch can be either an electrical proximity switch or pneumatic valve. The stowage consists of a cast aluminium base on which is mounted a tapered nozzle guide. The nozzle locks on to an inexpensive replaceable bayonet connector made in high strength aluminium bronze alloy.



Hose Reel HEPC Nozzle Stowage with Interlock

Part No DCA10214/DCA10216

Technical Data

The FLUID TRANSFER HEPC Nozzle Stowage is an integrated unit that provides a positive locking engagement, nose protection and a built-in interlock switch. This switch can either be an electrical proximity switch or pneumatic valve. The stowage consists of a cast aluminium base on which is mounted a tapered nozzle guide. The nozzle locks on to an inexpensive replaceable bayonet connector made in high strength aluminium bronze alloy. When the nozzle is stowed a central nylon plunger operates the interlock switch concealed in the base. On the pneumatic interlock version the plunger activates a lever operated spool. On the electrical interlock version the plunger rotates a magnet over a proximity switch, which changes the magnetic field and operates the switch.

Options

Two different nozzle guides are available to suit the AVERY HARDOLL Hose End Pressure Control Nozzle and the J C CARTER HEPC Nozzle. Customer to specify Nozzle type when purchasing.

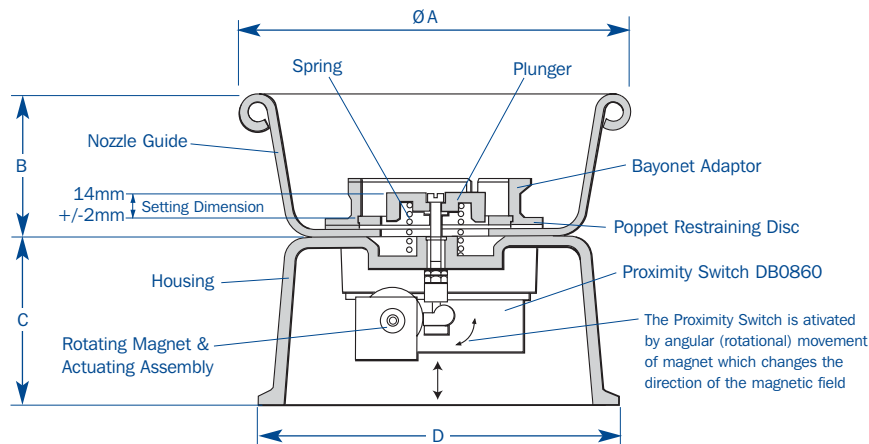

DCA10214 Electrically Actuated

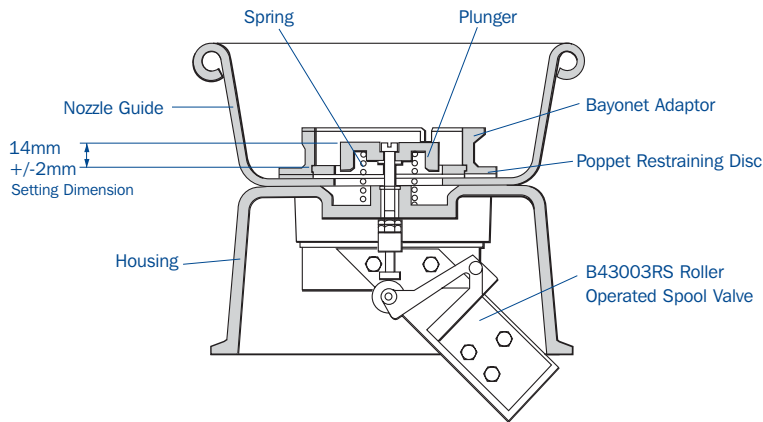

DCA10216 Pneumatically Actuated

Dimensions.

Item	Part No.	Nozzle Type	A	B	C	D	Mass
Nozzle Stowage (Electrical Interlock)	DCA10214	AVERY	Ø 190mm	70mm	85	210 x 170	2.3 Kg
		CARTER	Ø 162mm	50mm			
Nozzle Stowage (Pneumatic Interlock)	DCA10216	AVERY	Ø 190mm	70mm	85	210 x 170	2.4 Kg
		CARTER	Ø 162mm	50mm			

FTI's policy of continuous improvement means we reserve the right to alter designs and specifications without notice. The descriptions, illustrations and product references in the datasheet are for information purposes only and are not binding.



2. 1/2 Inch Nozzle Isolating Valve



Part No DBA11706/DCA10320

Application

Permits virtual 'dry break' for strainer inspection and nozzle change.

Connections Available

Mates to any male 2.1/2" BSP thread end permitting quick connection to a 2.1/2" male adaptor.

Features

- High strength aluminum alloy.
- High Nitrile Seals
- Standard versions have 2.1/2 inch BSPPM / 2.1/2 inch BSPPF threads.
- Lightweight - 950 gms.
- Short in length - 60mm effective length.
- Low pressure drop - less than 0.2 bar (3 PSI) at 1800 litres per minute.
- Operating temperature range - 25°C to + 80°C.

Options

- Optional 2.1/2 inch NPT threaded version available to special order.
- Suitable for pressures up to 20 bar (300 PSI) open or closed.
- Available without a drag ring (for deck hose nozzles) - or - with a drag ring (for reel hose nozzles).



Specification

The FLUID TRANSFER Nozzle Isolating Valve is designed to enable "dry-break" strainer inspection and/or nozzle removal to be carried out. This eliminates the need to drain down the hose. Unlike many units currently in use this valve is fully compatible with all nozzles having 2 1/2 inch BSPP threaded quick disconnects without creating a hybrid unit. (2.1/2 inch NPT version also available to special order).

The unit is light, short, easily handled and easy to operate for the short periods it is actually 'in use'.

A positive lock in the open and closed position is provided in addition to a "tell-tale" which indicates whether the valve is in the open or closed position.

The unit is constructed from fully heat treated high strength aluminium alloy and stainless steel.



2. 1/2 Inch Nozzle Isolating Valve

Part No DBA11706/DCA10320

Technical Data

The Fluid Transfer Nozzle Isolating Valve can also be fitted to the upstream end of the hose - between the hose and the hose reel hub or in the case of deck hoses - between the hose and the deck hose swivel. This is particularly useful on refuelling vehicles where the hose reel, deck hose swivel or upstream valves cannot withstand a 20 bar (300 PSI) test pressure and enables the hoses to be "in-situ" pressure tested (without removal from the vehicle). The only tool required to operate the unit is a 6 mm hexagonal (Allen) key - one is provided with each unit and is also a standard item in a fitter's toolbox. Likewise no special tools are required to service the unit.

Features

- DBA11706 mates with any fuelling nozzle utilizing 2.1/2 inch BSPP threaded inlet.
- Suitable for pressures up to 20 bar (300 PSI) open or closed.
- Lightweight - 950 gms.
- Short in length - 60mm effective length.
- Low pressure drop - less than 0.2 bar (3 PSI) at 1800 litres per minute.
- Wrought high strength aluminium alloy construction for maximum toughness.
- Easy to replace inexpensive seals.
- Operating temperature range - 25°C to + 80°C.

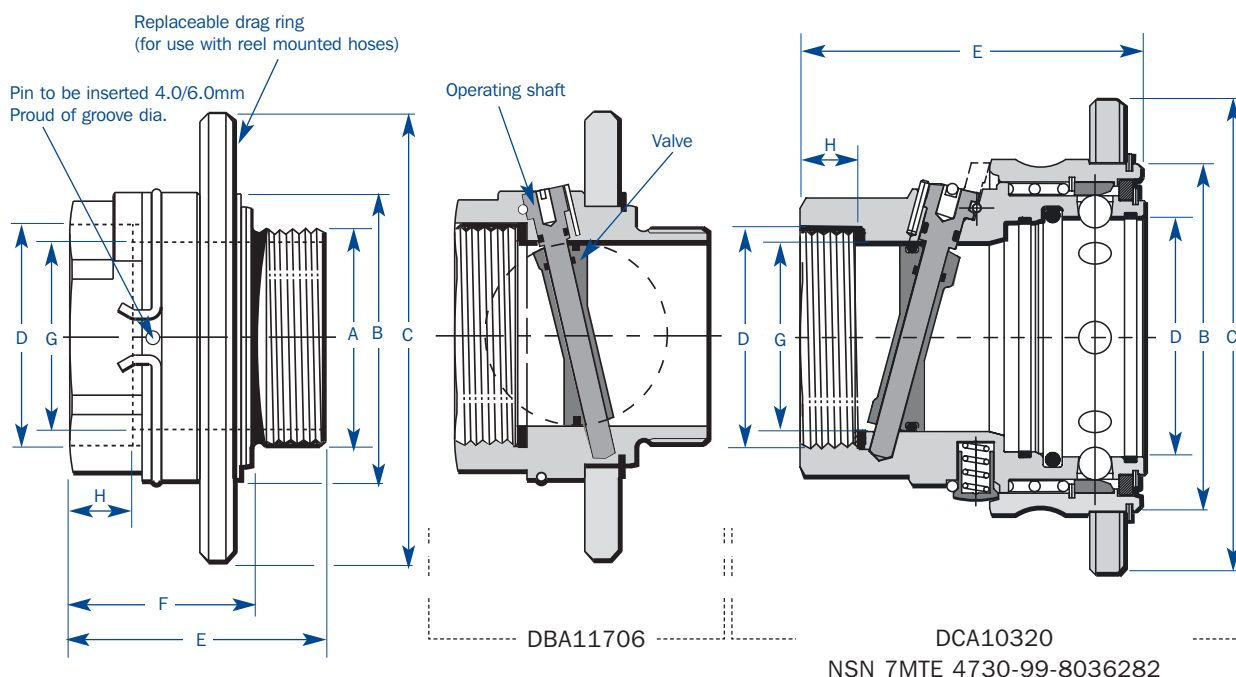

Options

- Standard versions have DBA11706 2.1/2 inch BSPPM / 2.1/2 inch BSPPF threads.
- Optional 2.1/2 inch NPT threaded version available to special order.
- Optional Quick Disconnect version DCA 10320 with 'F Profile' Flight Refuelling attachment.
- Available without a drag ring (for deck hose nozzles) - or - with a drag ring (for reel hose nozzles).

Dimensions.

Item	Part No.	A	B	C	D	E	F	G	H
Nozzle Isolating Valve With Drag Ring	DBA11706	2½" BSPP	Ø100mm	Ø160mm	2½" BSPP	90mm	65	Nominal 63mm	18.5mm
Nozzle Isolating	DBA11706-1	2½" BSPP	Ø100mm	Ø160mm	2½" BSPP	90mm	65	Nominal 63mm	18.5mm
Quick Disconnect With Drag Ring	DCA10320	F Profile Flight Refuelling	Ø120mm	Ø160mm	2½" BSPP	116mm	-	Nominal 63mm	18.5mm

FTI's policy of continuous improvement means we reserve the right to alter designs and specifications without notice. The descriptions, illustrations and product references in the datasheet are for information purposes only and are not binding. (updated August 07)



Applications

Permits easy handling of a hydrant servicing unit's intake hose and prevents the hose scraping along the ground.

Sizes Available

Available to suit 80mm (3") and 100mm (4") diameter hoses.

Features

- Plated Steel. Synthetic Rubber wheels.
- Reduce hosed wear due to generous ground clearance.
- Swivelling castors for easy movement.



Specification

The trolleys are designed to give the intake hose generous ground clearance, which minimises the likelihood of the hose scraping along the ground. This reduces damage and costly replacements. The Fluid Transfer Hose Trolley is designed to be used in conjunction with the Fluid Transfer 'Easilift' which enables the heavy Hydrant Dispenser Intake Hose to be handled easily.

Fluid Transfer Hose Trolley's can be supplied in the standard 2-wheel variant or the more stable 4-wheel version to suit requirements. Hose trolleys are also available with special mounting brackets to suit hydraulic stowage rails and can be supplied in two different sizes to accommodate various diameters of intake hose.



Hydrant Dispenser Intake Hose Trolley

Part No DB3323-1/DB5770

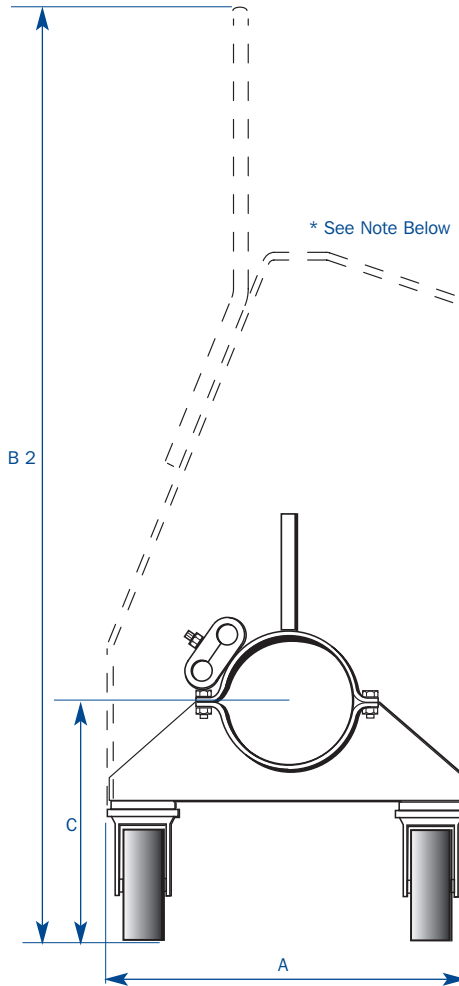

Technical Data

The body of the unit is constructed from steel whilst the castors are synthetic rubber. The combination of the two materials gives a robust long lasting solution.

The trolleys are fabricated in steel and are far more robust and durable than the cast aluminium versions which are prone to metal fatigue and fracture. The swivelling castors are fitted with 100mm diameter solid tyre wheels which can be easily removed and replaced (single bolt fixing).

The ends of the hose clamp are flared to prevent sharp edges from damaging the hose. Fixing brackets are attached to the upper clamp for supporting fuel and air sense lines.

Service

Fluid Transfer International offers a full support service. Due to the robust nature of the product repair is very unlikely however the castors may wear down. These are available individually and can be replaced by a single bolt.

Options

The trolleys are available in a number of configurations depending on options selected. Other pairings can be offered to provide the end user with tailored operational solutions at competitive pricing.

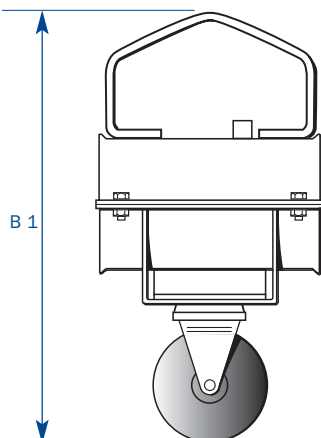

Part Number	Hose Manufacturer	Number of wheels	Intake Hose diameter
DB5770	Elaflex	2	80mm
DB3323-1	Elaflex	2	100mm
DC21400	Elaflex	4	100mm
DC22272*	Elaflex	2	100mm

*Suits Hydraulic Lift Rail

Dimensions

Part	A	B1	B2*	C	Weight
Hose Trolley 80mm	300mm	425mm	668mm	220mm	4.3 Kg
Hose Trolley 100mm	320mm	395mm	668mm	220mm	7.5 Kg

FTI's policy of continuous improvement means we reserve the right to alter designs and specifications without notice. The descriptions, illustrations and product references in the datasheet are for information purposes only and are not binding. (updated August 07)



Applications

Easilift mechanism permitting lower lift, and stowage of a Dispenser Intake Hose Coupling.

Features

- Reduced lift loads – provides 2.5:1 mechanical advantage.
- Lightweight zinc plated steel design
- Stainless steel bucket
- Positive rubber grip handle
- Simple operation

Options

- Manual mechanical version (shown)
- Hydraulic powered version
- In-line and right angled (not proud of vehicle) versions



Specification

The Fluid Transfer Intake Coupling Easilift used in conjunction with the Fluid Transfer Intake Hose Easilift and Hose Trolley's are designed to make heavy 100mm (4") - Hydrant Dispenser Intake Hose Coupling assemblies easier to lower lift, and stow.

All aircraft refuelling hoses are heavy to handle but the 100mm Intake Hose is by far the heaviest and most awkward to lift. The operator has to bend over to reach the Intake Coupling handle, which is typically no more than 300mm above ground level.

This design considerably reduces the likelihood of the vehicle operator suffering from back strain.

Fluid Transfer (on request) can also offer a complete hydraulic system for lowering, lifting and stowing the Intake Hose.

Intake Coupling Easilift

Part No DD7104, DC7248

Technical Data

The Fluid Transfer Intake Coupling Easilift is a mechanical "over centre" device attached to the dispenser subframe consisting of an actuating handle, a lifting enclosed table (height adjustable) and a spring-loaded safety latch. The Easilift gives a mechanical advantage of approximately 2.5:1 and the actuating handle is located at a convenient height for the operator.

The cradle design receives a typical intake coupling complete with integral secondary pressure control and Deadman valve complete with retractable carriage. The Intake coupling stowage can be interlocked to ensure correct stowage prior to operator departing the area following completion of the fuelling exercise.

Options

The Intake Coupling Easilift is available in the following versions all with the tray facing outwards:

Part No	Item	Version
DD7104-1	RH Vehicle (handle facing outwards)	Standard
DD7104-2	LH Vehicle (handle facing outwards)	Standard
DC7248	RH/LH Vehicle (handle facing outwards)	On Request
DC8520	Hydraulic (handle facing outwards)	On Request

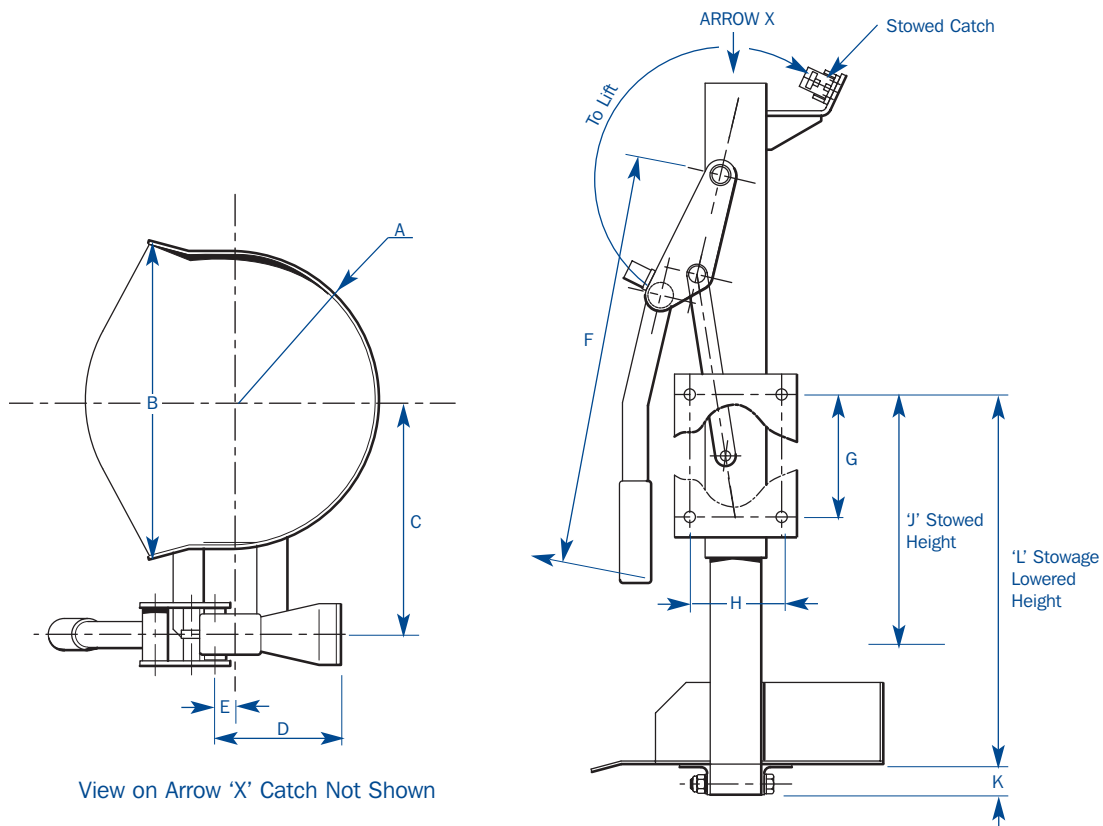

Dimensions

The Fluid Transfer Intake Coupling Easy-lift dimensions are as follows:

Part No.	A	B	C	D	E	F	G	H	J	K	L
DD7104	Ø290	310	230	124	15	Ø 410	120	90	200	30	392

Dimensions in (mm)

Closed height, J and open height, L.

Fixing dimensions G and H.

Weight 12 kg

FTI's policy of continuous improvement means we reserve the right to alter designs and specifications without notice.

The descriptions, illustrations and product references in the datasheet are for information purposes only and are not binding. (updated August 07)

T: +44 (0)1453 833 381

E: sales@fluidtransfergroup.com

W: fluidtransfer.com



Applications

Hard-wearing nylon sphere added to fuelling hoses to protect them from abrasion.

Sizes

Standard sizes to suit type C aviation hose:

Ø38mm (1½")

Ø50mm (2")

Ø63mm (2½")

Features

- Easy to assemble/replace
- Nylon wear-resistant body
- Brass fixings
- Bright colours for visibility.

Options

Additional sizes available on request are:

Ø75mm (3")

Ø100mm (4")



Specification

The Fluid Transfer Hose Bead is designed to reduce fuelling hose wear caused by abrasion when the hose is dragged across the ground. Hose beads attached to the surface of the fuelling hose raise the hose from the ground and act as a tougher wear resistant carrier.

Constructed of wear resistant nylon material and made in two halves the parts can be easily attached to the fuel hose.

The use of Hose Beads fitted to fuelling hoses benefits the operator in a number of ways, the Bead provides lower resistance when hauling the hose out or back and prolongs the life of the fuelling hose.

Fluid Transfer standard Hose Beads are sized to suit a Ø50mm (2") and Ø63mm (2½") bore Type C Aviation Hose, however Ø75mm (3") and Ø100mm (4") Hose Beads are also available on request.

Hose Beads

Part No DB4042 /DBA11502

Technical Data

The Fluid Transfer Hose Bead is available in two standard sizes and two others on request. All sizes consist of a nylon spherical body in two halves with internal body diameters to suit the outside diameter of the carrying hose.

The two halves are clamped together with brass screws and nuts to avoid sparking and build up of static charge.

An internal rib or retaining ring grips the hose, preventing the bead from slipping, as the two halves are clamped together.

The recommended position of the first Bead should be approximately 1.5m from the Hose End Nozzle and spacing thereafter at 1.2m along the Hose.

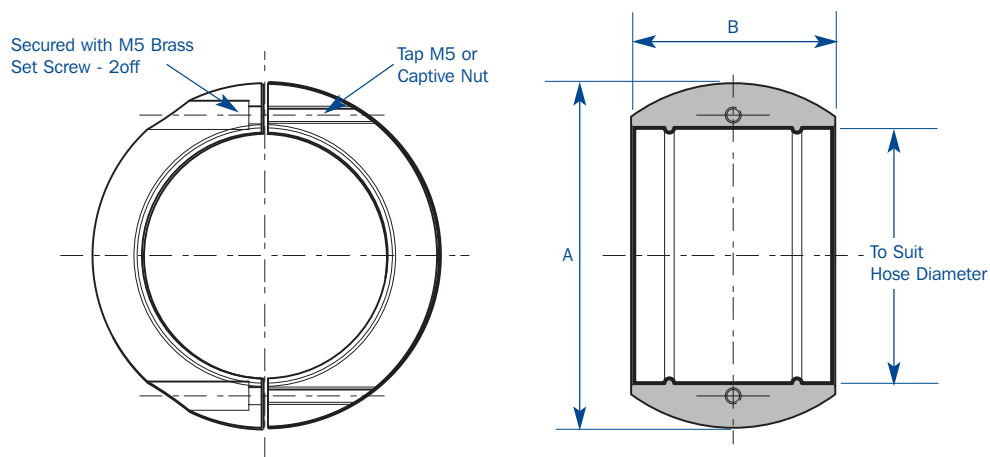

Dimensions

The Fluid Transfer Hose Bead is available in four sizes. Standard sizes are Ø38mm (1½") Ø50mm (2") and Ø63mm (2½") details of the larger Ø75mm (3") and Ø100mm (4") sizes are available on request

Colour	Part No	Option	Hose Diameter		A	B	Weight
			(mm)	Inch			
Yellow	SK3204	Standard	Ø38	Ø1½"	Ø75	50	0.11kg
Yellow	DBA11502	Standard	Ø50	Ø2"	Ø90	52	0.12kg
Yellow	DB4042	Standard	Ø63	Ø2½"	Ø108	64	0.20kg
Black Only	DBA11508	Option on request	Ø75	Ø3"	Ø125	60	0.30kg
Yellow	DBA11504	Option on request	Ø100	Ø4"	Ø156	65	0.50kg

Dimensions in (mm)

Maintenance

Hose beads require no maintenance only replacement when locally worn "flat" exceeds 40mm length.





Applications

A multi purpose reel, used for distribution of petroleum products, aviation fuel, fuel oils, Lpg and other liquids.

Features

- Fabricated in carbon or stainless steel
- Fluid path - stainless steel or carbon steel
- Seals - Viton or nitrile O-rings
- Manual drive
- Hand - rewind crank handle 90° or 20° option
- Floor or frame-mounted
- Pin lock or friction brake

Options

Options include

- Similar reel designs for other liquids
- Flexible reel dimensions to suit application.



Specification

The Fluid Transfer MK11 Horizontal Manual Rewind Hose Reel is a flexible design platform allowing a variety of tailored applications to suit customer requirements. The basic unit consists of a Drum and Swan Neck attachment supported on a solid Centre Shaft with a splined Hollow Shaft at one end. The Hollow Shaft allows liquid to travel from the Inlet connection along the Drum's axis of rotation into the Hose contained on the Drum. "O" Ring Seals between the Swan Neck and Hollow Shaft permit leak free rotation of the Drum.

The MK11 Hose Reel design can be used for a variety of fuel delivery applications.

MK11 Horizontal Manual Rewind Hose Reel

Part No MK11

Technical Data

The Fluid Transfer MK11 Hose Reel in its simplest form features a drum supported on plane bearings by a static through-Centre Shaft. The static through-Centre Shaft is connected via a spline to a hollow shaft at the liquid inlet end. The Hollow Shaft is held in a Clamp located on an A-frame Support. The other end of the Centre Shaft is clamped to the Support Frame with sufficient space between the drum and support Frame for the drive mechanism.

The fluid passage begins at the inlet flange of the static hollow shaft. A radial hole allows the fuel out of the shaft where a swan neck, connected to the drum, feeds the liquid to the hose stored on the drum. The Swan Neck is free to rotate around the hollow centre shaft with the drum. Sealing of the swan neck on the Centre Shaft is achieved with the use of Viton 'O' Ring Seals and gland pack.

Options

The MK11 Hose Reel can be supplied complete with hose and nozzles. Options for consideration are as follows:

Part No	Item	Variation	Comment
MK11	Connections	Inlet	Threaded 25mm (1") to 63mm (2½") BSP. F.or flanged to suit application
		Outlet	Swan Neck threaded hose connection 25mm (1") to 63mm (2½") BSP. M.
	Hoses	25mm (1") to 63mm (2½")	Drum sizes vary to suit hose diameter and length.
	Drum	Single/Twin	Drum sizes vary to suit hose diameter and length. Twin Drum supported on common centre shaft.
	Rewind	Manual	Standard crank or extra long handle at 20° or 90°
	Materials of Construction	Mild steel structures	Fluid flow path – Stainless or Carbon Steel, Aluminium or Gun Metal
		All stainless steel	To suit hostile environments
	Support Frame	Floor or frame-mounted.	
	Handing	Left	Drive mechanism on left-hand side
		Right	Drive mechanism on right-hand side
	Enclosure	Optional safety enclosure	Can include Lockable Roller Blind and Hose Guide Rollers
	Paint System	Natural, Prime, Gloss to client specification	Customer to specify.
	Drum Lock/brake	Lock	Rim locking mechanism
		Brake	Friction brake

Note for LPG the Swan Neck is replaced with a Glenthorp Gland.

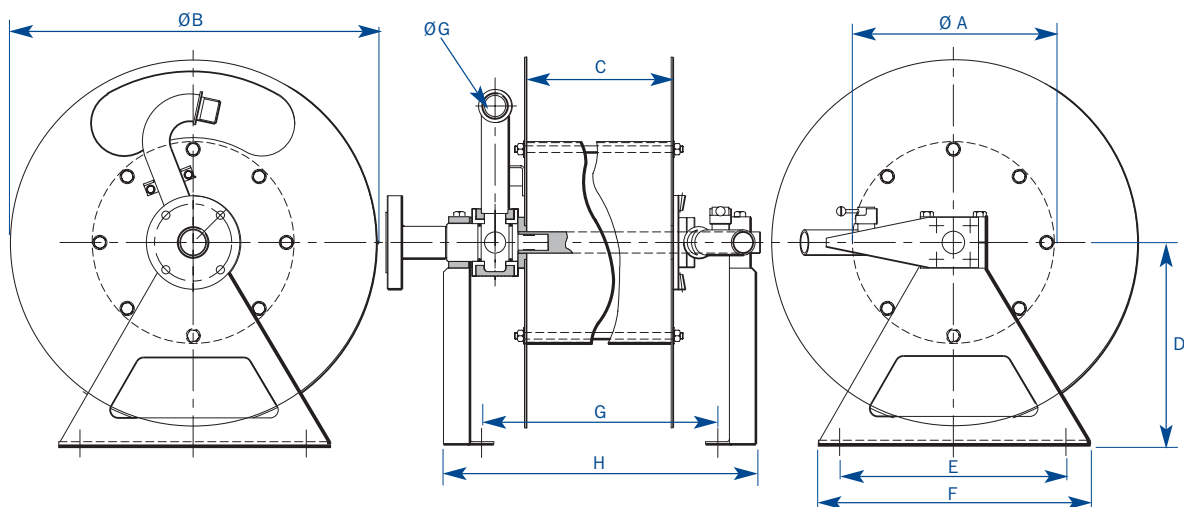

Dimensions

Dimensions for Hose Reel assemblies are as follows (typical only):

Part No	Hose Diameter	Max Hose Length	A	B	C	D	E	F	G	H
MK11	32mm (1¼")	60m (200ft)	Ø250	Ø535	262	305	343	406	883	1000
	38mm (1½")	50m (165ft)								
	50mm (2")	40m (130ft)								

Dimensions in (mm)

FTi's policy of continuous improvement means we reserve the right to alter designs and specifications without notice.

The descriptions, illustrations and product references in the datasheet are for information purposes only and are not binding.



UNITS CONVERSION TABLES

Overview

These conversion tables are provided for your reference.

Units Conversion Tables

Table 1	Multiples and Submultiples of SI Units
Table 2	Length Units
Table 3	Area Units
Table 4	Volume Units
Table 5	Mass Units
Table 6	Density Units
Table 7	Volumetric Liquid Flow Units
Table 8	Volumetric Gas Flow Units
Table 9	Mass Flow Units
Table 10	High Pressure Units
Table 11	Low Pressure Units
Table 12	Speed Units
Table 13	Torque Units
Table 14	Dynamic Viscosity Units
Table 15	Kinematic Viscosity Units
Table 16	Temperature Conversion Formulas

Table 1: Multiples and Submultiples of SI units

Prefix	Symbol	Multiplying Factor	
exa	E	10 ¹⁸	1 000 000 000 000 000 000
peta	P	10 ¹⁵	1 000 000 000 000 000
tera	T	10 ¹²	1 000 000 000 000
giga	G	10 ⁹	1 000 000 000
mega	M	10 ⁶	1 000 000
kilo	k	10 ³	1 000
hecto*	h	10 ²	100
deca*	da	10	10
deci*	d	10 ⁻¹	0.1
centi	c	10 ⁻²	0.01
milli	m	10 ⁻³	0.001
micro	u	10 ⁻⁶	0.000 001
nano	n	10 ⁻⁹	0.000 000 001
pico	p	10 ⁻¹²	0.000 000 000 001
femto	f	10 ⁻¹⁵	0.000 000 000 000 001
atto	a	10 ⁻¹⁸	0.000 000 000 000 000 001

* these prefixes are not normally used

Table 2: Length Units

Millimeters	Centimeters	Meters	Kilometers	Inches	Feet	Yards	Miles
mm	cm	m	km	in	ft	yd	mi
1	0.1	0.001	0.000001	0.03937	0.003281	0.001094	6.21e-07
10	1	0.01	0.00001	0.393701	0.032808	0.010936	0.000006
1000	100	1	0.001	39.37008	3.28084	1.093613	0.000621
1000000	100000	1000	1	39370.08	3280.84	1093.613	0.621371
25.4	2.54	0.0254	0.000025	1	0.083333	0.027778	0.000016
304.8	30.48	0.3048	0.000305	12	1	0.333333	0.000189
914.4	91.44	0.9144	0.000914	36	3	1	0.000568
1609344	160934.4	1609.344	1.609344	63360	5280	1760	1

Table 3: Area Units

Millimeter square	Centimeter square	Meter square	Inch square	Foot square	Yard square
mm ²	cm ²	m ²	in ²	ft ²	yd ²
1	0.01	0.000001	0.00155	0.000011	0.000001
100	1	0.0001	0.155	0.001076	0.00012
1000000	10000	1	1550.003	10.76391	1.19599
645.16	6.4516	0.000645	1	0.006944	0.000772
92903	929.0304	0.092903	144	1	0.111111
836127	8361.274	0.836127	1296	9	1

Table 4: Volume Units

Centimeter cube	Meter cube	Liter	Inch cube	Foot cube	US gallons	Imperial gallons	US barrel (oil)
cm ³	m ³	ltr	in ³	ft ³	US gal	Imp. gal	US brl
1	0.000001	0.001	0.061024	0.000035	0.000264	0.00022	0.000006
1000000	1	1000	61024	35	264	220	6.29
1000	0.001	1	61	0.035	0.264201	0.22	0.00629
16.4	0.000016	0.016387	1	0.000579	0.004329	0.003605	0.000103
28317	0.028317	28.31685	1728	1	7.481333	6.229712	0.178127
3785	0.003785	3.79	231	0.13	1	0.832701	0.02381
4545	0.004545	4.55	277	0.16	1.20	1	0.028593
158970	0.15897	159	9701	6	42	35	1

Table 5: Mass Units

Grams	Kilograms	Metric tonnes	Short ton	Long ton	Pounds	Ounces
g	kg	tonne	shton	Lton	lb	oz
1	0.001	0.000001	0.000001	9.84e-07	0.002205	0.035273
1000	1	0.001	0.001102	0.000984	2.204586	35.27337
1000000	1000	1	1.102293	0.984252	2204.586	35273.37
907200	907.2	0.9072	1	0.892913	2000	32000
1016000	1016	1.016	1.119929	1	2239.859	35837.74
453.6	0.4536	0.000454	0.0005	0.000446	1	16
28	0.02835	0.000028	0.000031	0.000028	0.0625	1

Table 6: Density Units

Gram/milliliter	Kilogram/meter cube	Pound/foot cube	Pound/inch cube
g/ml	kg/m ³	lb/ft ³	lb/in ³
1	1000	62.42197	0.036127
0.001	1	0.062422	0.000036
0.01602	16.02	1	0.000579
27.68	27680	1727.84	1

Table 7: Volumetric Liquid Flow Units

Liter/second	Liter/minute	Meter cube/hour	Foot cube/minute	Foot cube/hour	US gallons/minute	US barrels (oil)/day
L/sec	L/min	M ³ /hr	ft ³ /min	ft ³ /hr	gal/min	US brl/d
1	60	3.6	2.119093	127.1197	15.85037	543.4783
0.016666	1	0.06	0.035317	2.118577	0.264162	9.057609
0.277778	16.6667	1	0.588637	35.31102	4.40288	150.9661
0.4719	28.31513	1.69884	1	60	7.479791	256.4674
0.007867	0.472015	0.02832	0.01667	1	0.124689	4.275326
0.06309	3.785551	0.227124	0.133694	8.019983	1	34.28804
0.00184	0.110404	0.006624	0.003899	0.2339	0.029165	1

Table 8: Volumetric Gas Flow Units

Normal meter cube/hour	Standard cubic feet/hour	Standard cubic feet/minute
Nm ³ /hr	scfh	scfm
1	35.31073	0.588582
0.02832	1	0.016669
1.699	59.99294	1

Table 9: Mass Flow Units

Kilogram/hour	Pound/hour	Kilogram/second	Ton/hour
kg/h	lb/hour	kg/s	t/h
1	2.204586	0.000278	0.001
0.4536	1	0.000126	0.000454
3600	7936.508	1	3.6
1000	2204.586	0.277778	1

Table 10: High Pressure Units

Bar	Pound/square inch	Kilopascal	Megapascal	Kilogram force/centimeter square	Millimeter of mercury	Atmospheres
bar	psi	kPa	MPa	kgf/cm ²	mm Hg	atm
1	14.50326	100	0.1	1.01968	750.0188	0.987167
0.06895	1	6.895	0.006895	0.070307	51.71379	0.068065
0.01	0.1450	1	0.001	0.01020	7.5002	0.00987
10	145.03	1000	1	10.197	7500.2	9.8717
0.9807	14.22335	98.07	0.09807	1	735.5434	0.968115
0.001333	0.019337	0.13333	0.000133	0.00136	1	0.001316
1.013	14.69181	101.3	0.1013	1.032936	759.769	1

Table 11: Low Pressure Units

Meter of water	Foot of water	Centimeter of mercury	Inches of mercury	Inches of water	Pascal
mH ₂ O	ftH ₂ O	cmHg	inHg	inH ₂ O	Pa
1	3.280696	7.356339	2.896043	39.36572	9806
0.304813	1	2.242311	0.882753	11.9992	2989
0.135937	0.445969	1	0.39368	5.351265	1333
0.345299	1.13282	2.540135	1	13.59293	3386
0.025403	0.083339	0.186872	0.073568	1	249.1
0.000102	0.000335	0.00075	0.000295	0.004014	1

Table 12: Speed Units

Meter/second	Meter/minute	Kilometer/hour	Foot/second	Foot/minute	Miles/hour
m/s	m/min	km/h	ft/s	ft/min	mi/h
1	59.988	3.599712	3.28084	196.8504	2.237136
0.01667	1	0.060007	0.054692	3.281496	0.037293
0.2778	16.66467	1	0.911417	54.68504	0.621477
0.3048	18.28434	1.097192	1	60	0.681879
0.00508	0.304739	0.018287	0.016667	1	0.011365
0.447	26.81464	1.609071	1.466535	87.99213	1

Table 13: Torque Units

Newton meter	Kilogram force meter	Foot pound	Inch pound
Nm	kgfm	ftlb	inlb
1	0.101972	0.737561	8.850732
9.80665	1	7.233003	86.79603
1.35582	0.138255	1	12
0.112985	0.011521	0.083333	1

Table 14: Dynamic Viscosity Units

Centipoise*	Poise	Pound/foot-second
cp	poise	lb/(ft·s)
1	0.01	0.000672
100	1	0.067197
1488.16	14.8816	1

Table 15: Kinematic Viscosity Units

Centistoke*	Stoke	Foot square/second	meter square/second
cs	St	ft ² /s	m ² /s
1	0.01	0.000011	0.000001
100	1	0.001076	0.0001
92903	929.03	1	0.092903
1000000	10000	10.76392	1

*note: centistokes x specific gravity = centipoise

Table 16: Temperature Conversion Formulas

Degree Celsius (°C)	$(°F - 32) \times 5/9$
	$(K - 273.15)$
Degree Fahrenheit (°F)	$(°C \times 9/5) + 32$
	$(1.8 \times K) - 459.67$
Kelvin (K)	$(°C + 273.15)$
	$(°F + 459.67) \div 1.8$

November 2007

